

ONE2

Lightweight Tandem Stroller

The logo for Britax, featuring the word "britax" in a lowercase, sans-serif font with a white wavy line underneath.

0_{KG}

20_{KG}

(newborn - 4 years approx.)

IMPORTANT KEEP THIS
BOOKLET IN A SAFE PLACE
FOR FUTURE REFERENCE

Contents

About Your Stroller

Stroller Warnings and Important Notes	04
Lift & Carry Correctly	06
What's in the Box: Stroller Parts	07
What's in the Box: Accessories	08
Optional Accessories & Compatibility	08
Stroller Features	09
Stroller Configurations: Single	11
Stroller Configurations: Tandem	12

Stroller Assembly

Opening the Stroller Frame	13
Attaching & Removing the Rear Wheels	14
Attaching & Removing the Front Wheels	14
Attaching the Seat Unit	15
Attaching the Canopy	16
Attaching the Arm Bar	17

Bassinet Assembly

Converting the Seat to Bassinet	18
---------------------------------	----

Stroller Operation

Operating the Brake	20
Front Wheel Swivel Lock	20
Adjusting the Backrest	21
Adjusting the Leg Rest	22
Adjusting the Handlebar Height	22
Securing the Harness	23
Adjusting the Harness	24
Releasing the Harness	25
Storage Basket	26
Using the Tether Strap	27
Removing & Reversing the Seat Unit	28
Using the Stroller	29
Folding the Stroller	30
Lifting & Carrying the Stroller	31

Stroller Accessories

Seat Liner	32
Second Seat	
Second Seat Warnings & Important Notes	34
Attaching the Wheel Guards	35
Attaching & Removing the Seat Extenders	35
Attaching the Second Seat Unit	36
Removing the Second Seat Unit	37
Baby Capsule	
Baby Capsule Warnings & Important Notes	38
Installing & Removing the Britax Click & Go™ Baby Capsule Adaptors	39
Installing the Britax Baby Capsule	40
Removing the Britax Baby Capsule	41
Attaching the Rain Cover	42
Attaching the Sun Cover	43
Attaching the Cup / Bottle holder	43
Installing the Newborn & Toddler Comfort Pack	44

Contents

Care & Maintenance

Care & Maintenance	46
Warranty	49

Always follow the manufacturer's instructions. Read all instructions carefully before assembly and use of this stroller.

The correct use and maintenance of this product is essential.

WARNINGS

- FOLLOW THE MANUFACTURER'S INSTRUCTIONS
- PUT ON ALL THE BRAKES WHENEVER YOU PARK THE STROLLER.
- DO NOT LEAVE CHILDREN UNATTENDED.
- DO NOT CARRY EXTRA CHILDREN OR BAGS ON THIS STROLLER
- MAKE SURE CHILDREN ARE CLEAR OF ANY MOVING PARTS IF YOU ADJUST THE STROLLER, OTHERWISE THEY MAY BE INJURED.
- THE VEHICLE IS NOT TO BE USED AS AN UNSUPERVISED SLEEPING ENVIRONMENT
- DO NOT USE ANY ACCESSORIES OTHER THAN THOSE APPROVED FOR USE WITH THIS STROLLER BY BRITAX.
- IT IS UNSAFE TO USE ACCESSORIES NOT APPROVED FOR USE WITH THIS STROLLER.
- THE MAXIMUM WEIGHT OF THE CHILD IS NOT TO EXCEED:
BASSINET MODE 9KG, PARENT FACING MODE 15KG, WORLD FACING MODE 20KG, SECOND SEAT* 15KG. *ACCESSORIES SOLD SEPARATELY.

FOR IMPORTANT NOTES AND WARNINGS ON ACCESSORIES – REFER TO THEIR INDIVIDUAL SECTIONS IN THIS BOOK OR THE INSTRUCTION MANUAL INCLUDED WITH THE INDIVIDUAL PRODUCTS. THE MAXIMUM WEIGHT VARIES FOR EACH ACCESSORY.

IMPORTANT NOTES:

- Use great care when using the stroller on stairs, escalators, travelators or other moving surfaces.
- It is recommended to remove the child from the stroller before going up or down stairs or escalators.
- Do not lift the stroller by the arm bar (supplied) because it may disengage.
- Do not allow children to stand on the seat.
- Do not hang bags unless they are supplied or goods from the handle as this could cause the stroller to tip over.
- Do not leave the stroller and its accessories near an open fire or exposed flame.
- Do not place more than 12kg in the basket at single mode or 4kg at tandem mode, 1kg in the cup/bottle holder.



This **CAUTION** symbol is shown at certain steps in this instruction manual to highlight the danger of being injured by moving parts.

Lift & Carry Correctly

The SMART lifting technique: This technique can be used to pick up small light loads from low levels.

Size up the load

- Assess the load (size, shape, and weight).
- Assess whether the load needs to be moved;
- Where is it going to be placed? Check that there are no obstructions;
- Assess whether mechanical or human assistance is required.

Move the load as close to the body as possible

- A load is heavier to lift or carry if it is not close to the body.
- The whole hand should be used to ensure a firm grip.

Always bend your knees

- Maintain balance.
- Keep feet apart and in a comfortable position.
- Minimise lower back bending.
- Bend knees preferable at as large an angle as possible but not at a right angle - use a semi-squat in preference to a full squat.

Raise the load with your legs

- Achieve the lift smoothly and without jerkiness.
- Maintain the normal curvature of the spine to allow the force of the load to be distributed evenly from the spine to the pelvis.

Turn your feet in the direction that you want to move the load.

- Avoid unnecessary bending, twisting, and reaching.
- Change direction by turning your feet and not your back.
- To set the load down, squat down, keep your head up and let your legs do the work.

Remember to **THINK TALL** - chest lifted, shoulders relaxed, chin tucked in, and head level.

What's in the Box: Stroller Parts

1 x Stroller Frame

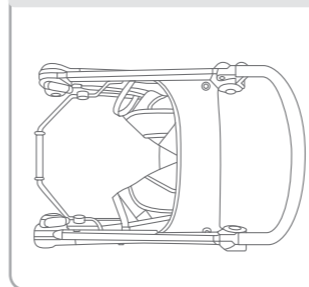

1 x Stroller Seat

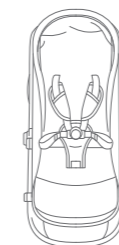

1 x Canopy

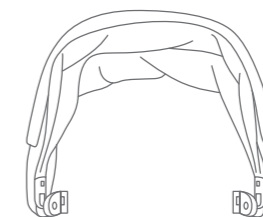

1 x Arm Bar



2 x Front Wheels

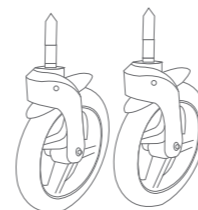

2 x Rear Wheels



1 x Seat Liner

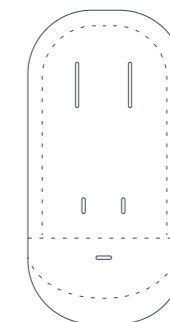

What's in the Box: Accessories

Optional Accessories (Sold Separately)

- Britax b-Pod baby capsule range
- Britax Click & Go™ baby capsule adaptors One2
- Britax One2 Second seat
- Britax Rain cover
- Britax Sun cover
- Britax Cup holder
- Britax Newborn & toddler comfort pack

Compatible with:

Selected competitor baby capsules, for detailed compatibility refer to:

Australia: britax.com.au New Zealand: britax.co.nz



Stroller Features

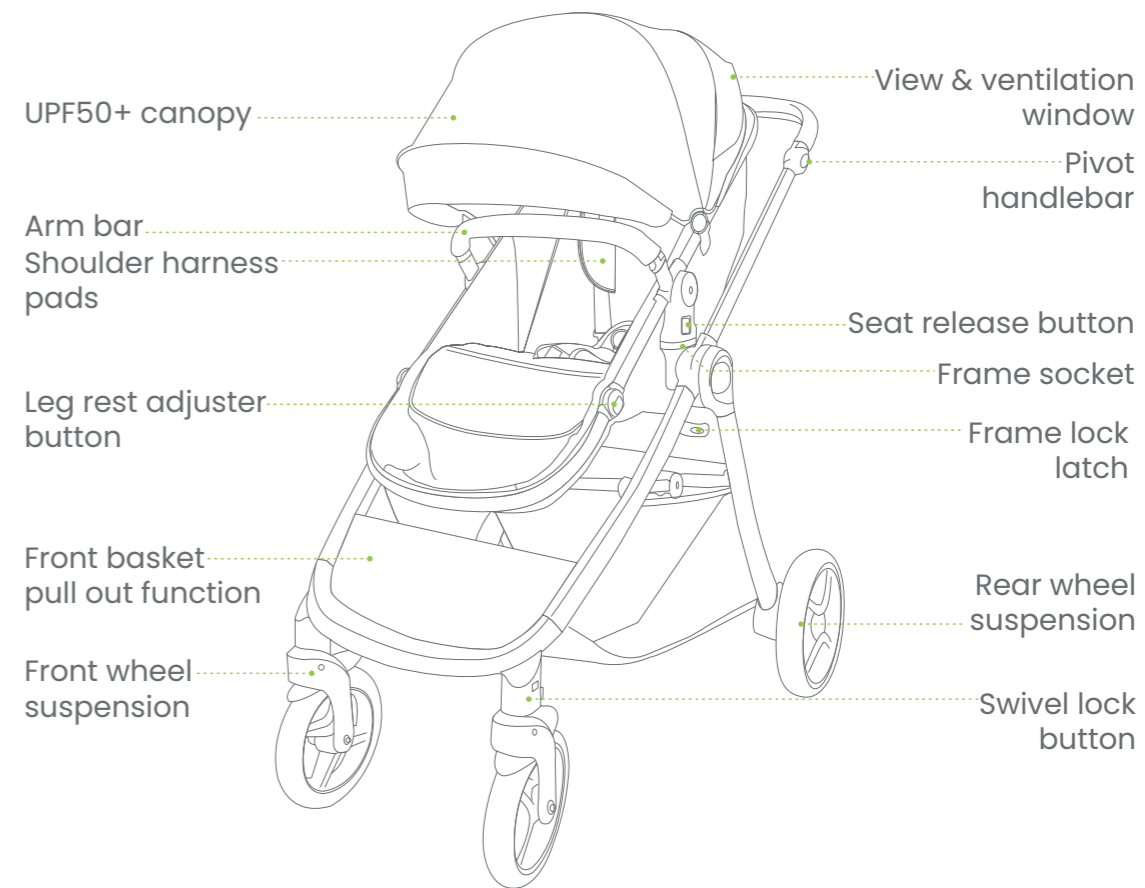

Stroller Features

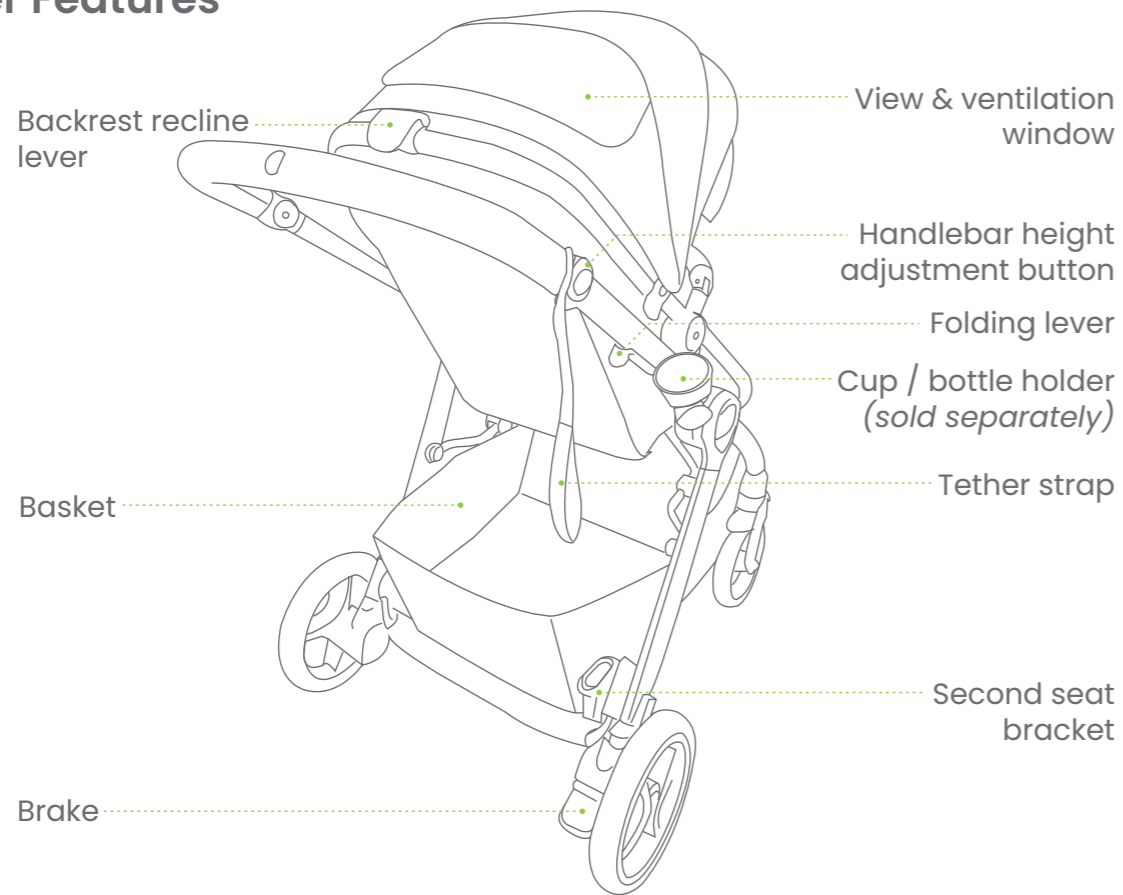

Stroller Configurations: Single

PLEASE NOTE: The One2 has 4 single configurations/modes and many adjustments to suit your needs. Shown with optional accessories here (sold separately).

DO NOT exceed maximum weight limits defined in the Baby Capsule, Bassinet and Accessories instruction manuals.

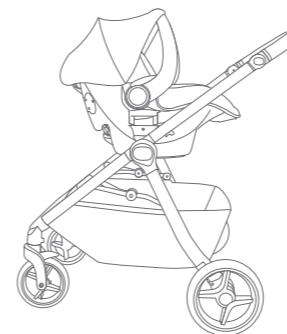

Travel system mode

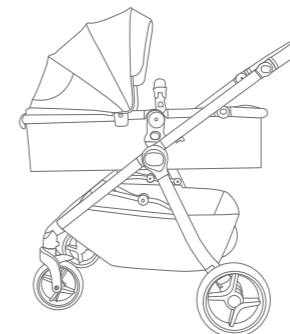

Bassinet mode



Parent facing mode

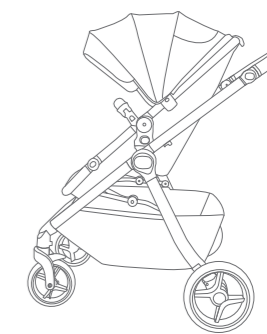

World facing mode

Stroller Configurations: Tandem

PLEASE NOTE: The One2 has 8 tandem configurations/modes and many adjustments to suit your growing family needs. Shown with optional accessories here (sold separately).

DO NOT exceed maximum weight limits defined in the Baby Capsule, Bassinet or Accessory instruction manuals.

Seat Extenders must be used on the top seat when in tandem mode to create more space between the seats (supplied with the Second Seat). Do not use the configuration shown here if there is not enough space for the lower child.

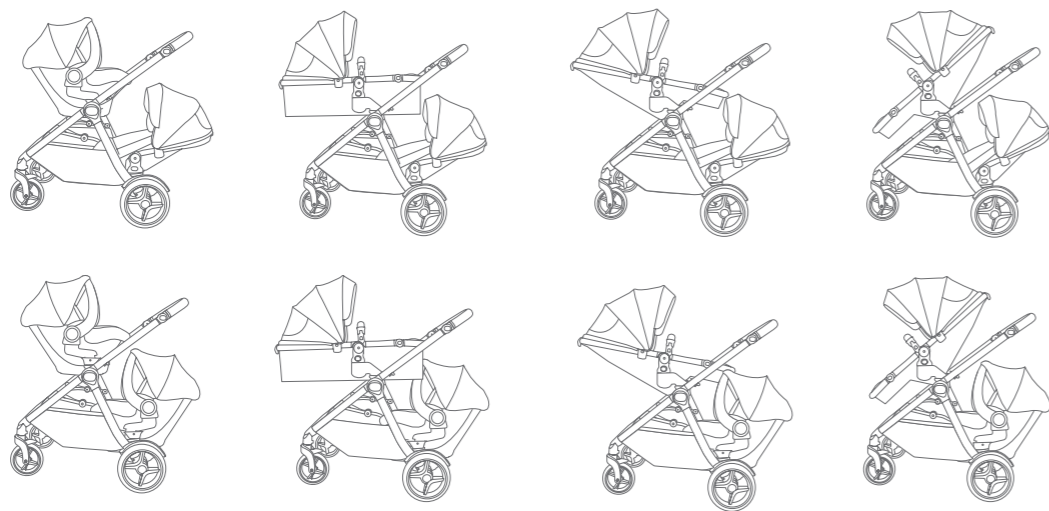

Stroller Assembly

Opening the Stroller Frame

IMPORTANT NOTES:

PLEASE REFER TO PAGE 6 FOR SMART LIFTING TECHNIQUES.

- Release the storage latch with due care and open the frame.
- When opening the stroller, be aware of the danger of being injured by moving parts and locking devices during the process. Keep all hands and limbs clear of these parts.
- There is potential for fingers or parts of the body to be injured when the stroller is being unfolded, due care should be exercised.
- Keep children clear of the stroller when unfolding the stroller.
- Open the stroller slowly and be careful where you place your hands. Keeping your hands on the handle is the best way to unfold the stroller.

A

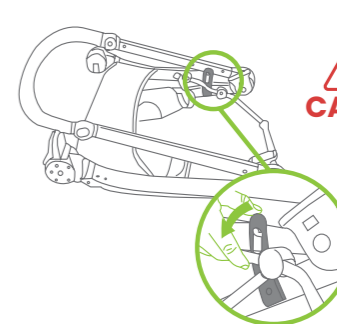

Release the frame lock inside the frame and slowly pull the handlebar up to open.

B

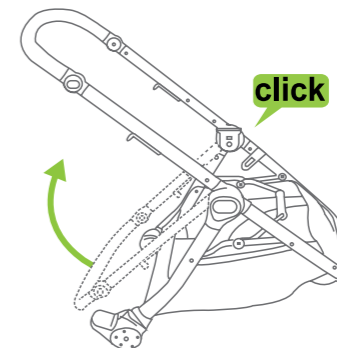

Lift the handle upwards until the frame is fully open and locked.

Attaching & Removing the Rear Wheels

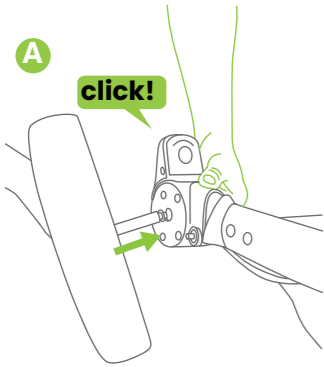

A. Insert wheel axle into the moulding and push in until you hear a 'click'. Pull on each wheel to make sure it is securely attached. Repeat the process if not locked in.

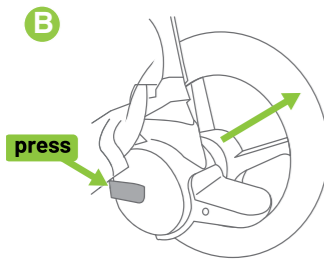

B. To remove the rear wheels, press and hold the release button in the wheel housing and pull away.

Attaching & Removing the Front Wheels

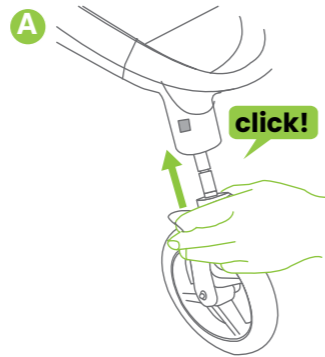

A. Insert each front swivel wheel assembly into the wheel moulding and push in until you hear a 'click'. Pull on each wheel to make sure it is securely attached. Repeat the process if not locked in.

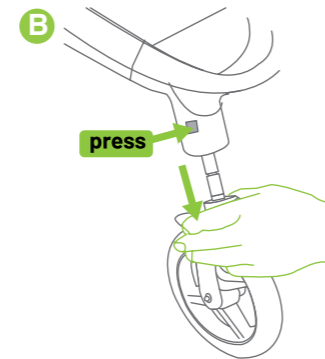

B. To remove the front wheels, push the release button on wheel moulding.

Attaching the Seat Unit

IMPORTANT NOTES:

Always remove your child from the stroller seat before installing, removing or changing the seat direction.

☺ **TIP:** The seat is reversible so it can be attached to the frame in the Parent or World facing position.

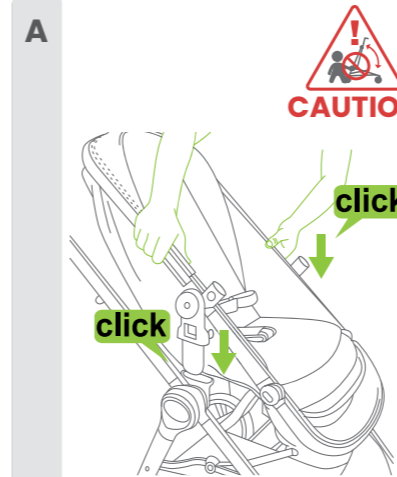

A Hold the stroller seat over the frame and align the seat connectors with frame sockets. Push down on the seat until both stroller seat connectors have locked into the frame sockets.

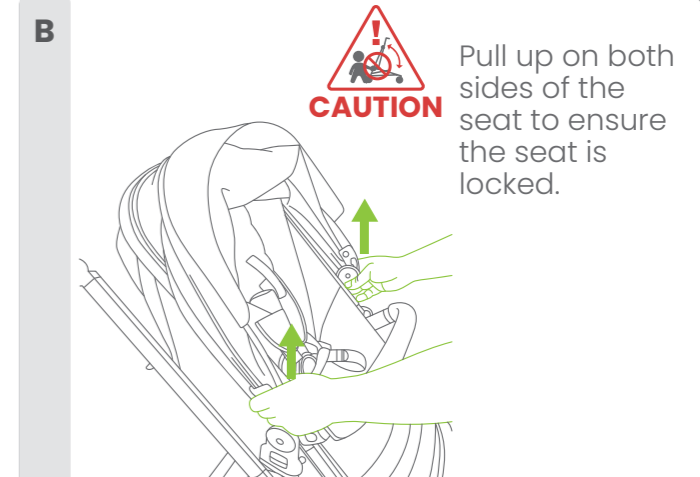

B Pull up on both sides of the seat to ensure the seat is locked.

Stroller Assembly

Attaching the Canopy

IMPORTANT NOTE: The sun is very strong. **DO NOT LEAVE YOUR CHILD EXPOSED TO THE SUN.** The canopy or hood on this product will not give your child total protection from the harmful rays of the sun.

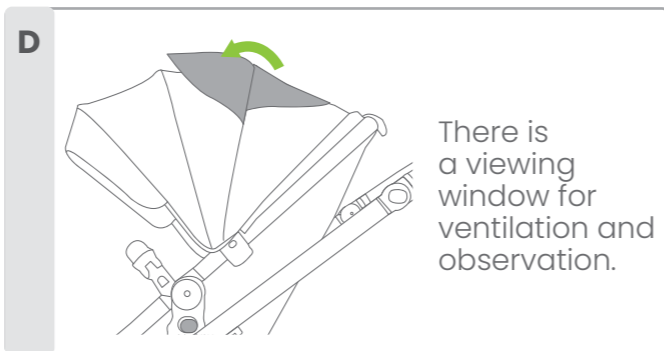
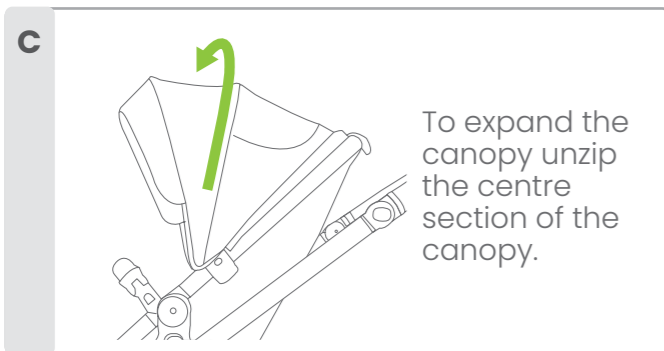
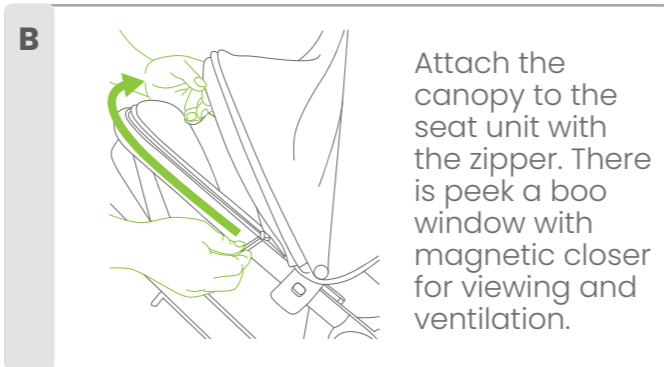
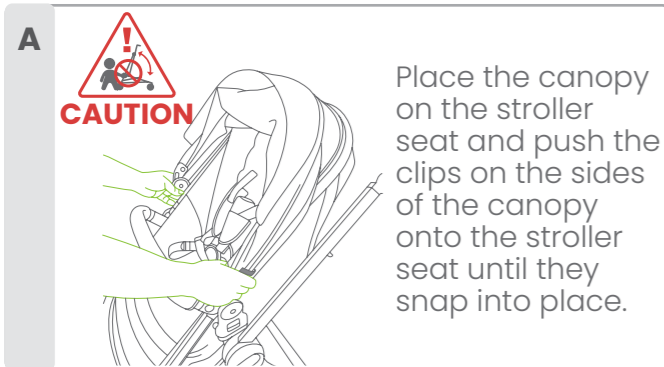

Stroller Assembly

Attaching the Arm Bar

WHEN A CHILD IS IN THE STROLLER, KEEP THE ARM BAR ATTACHED AT ALL TIMES.

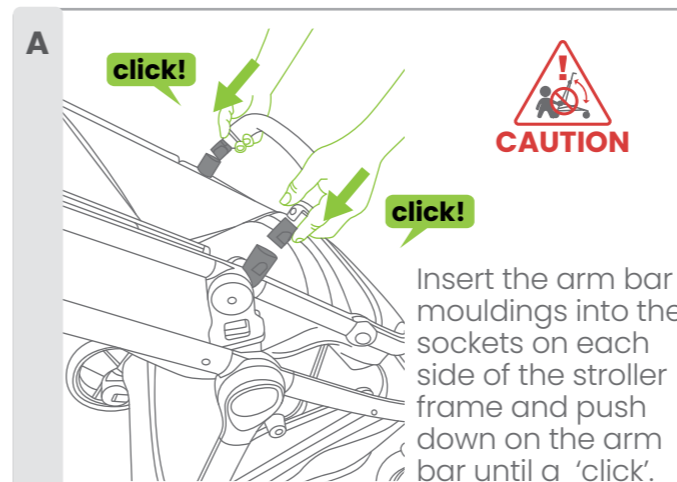

To assist with putting a child in the stroller, you can release the arm bar on one side. Press the button on the side of the arm bar moulding and pull the arm bar up and out of the socket. Rotate the arm bar clear of the stroller.

Reattach the arm bar after fastening the child in the harness.

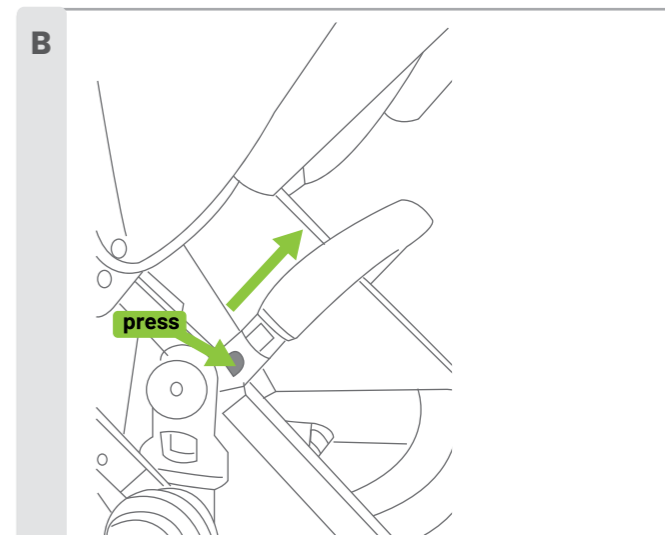

To remove the arm bar, press the button on each side of the arm bar moulding and pull arm bar up and out of the sockets.

Bassinet Assembly

Converting the Seat to Bassinet

WARNINGS:

- DO NOT USE FOR UNSUPERVISED SLEEPING.
- DO NOT USE THE BASSINET ONCE THE CHILD CAN SIT UP UNAIDED.
- DO NOT USE ANY ACCESSORIES OTHER THAN THOSE APPROVED FOR USE WITH THIS STROLLER BY BRITAX.
- IT IS UNSAFE TO USE ACCESSORIES NOT APPROVED FOR USE WITH THIS STROLLER.
- THE BASSINET CAN ONLY BE USED ON THE STROLLER FRAME, IT CAN NOT BE USED AS A STAND ALONE BASSINET.
- THE MAXIMUM WEIGHT OF THE CHILD USING THE BASSINET IS NOT TO EXCEED 9KGS.

A

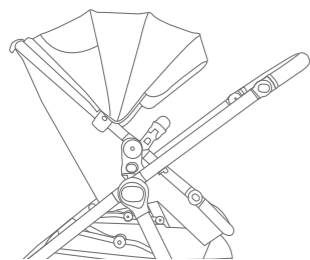

Stroller must be on parent facing mode.

B

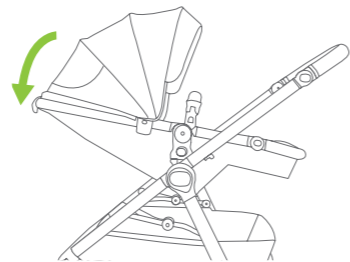

Adjust the backrest to the lowest recline position.

C

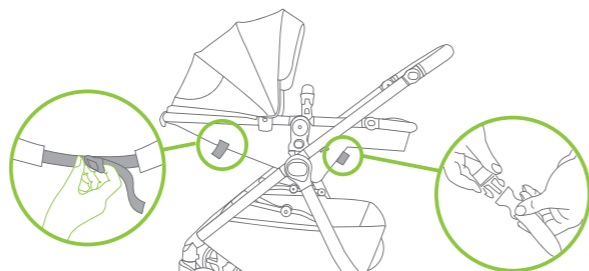

Pull the backrest clip to extend the strap all the way and push down the backrest. Unbuckle the clip under leg rest and push down the leg rest.

D

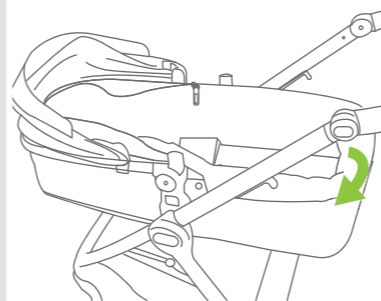

Ensure the seat liner lays flat on the bassinet to create a comfortable and secure space for your newborn.

E

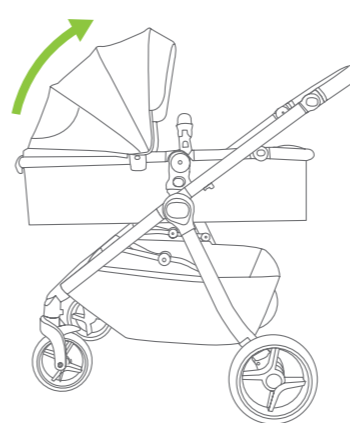

Pull the canopy up for protection. For attaching and using of canopy, please refer to page 16.

Bassinet Assembly

Operating the Brake

! WARNINGS: ALWAYS APPLY THE BRAKES WHEN THE STROLLER IS STATIONARY.

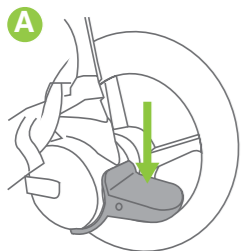

A. Push down the brake pedal to engage the brake.

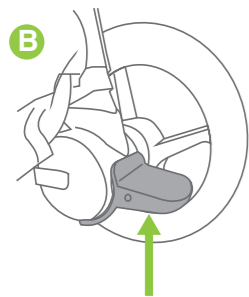

B. Push the brake pedal upward until the brake is disengaged.

Front Wheel Swivel Lock

⊙ **TIP:** Always lock the swivel wheels when using the stroller on rough surfaces as this will minimise wheel wobble. The swivel wheels should only be locked when the wheels are in the trailing position (wheels under frame).

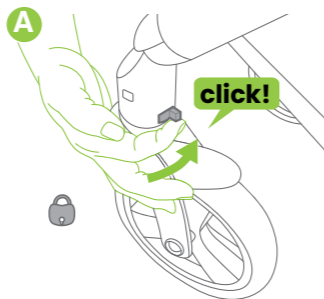

A. To lock the front wheels into the fixed position, slide the swivel wheel locking clip towards the inside of the frame until you hear a 'click'.

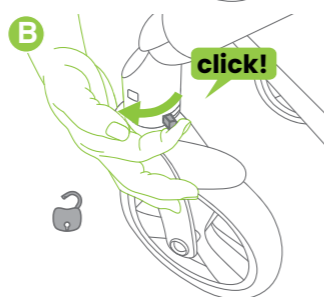

B. To allow the wheels to swivel, slide the black swivel wheel locking clip towards the outside of the frame until you hear a 'click'.

Adjusting the Backrest

! WARNINGS:

- **THE UPRIGHT POSITIONS ARE NOT SUITABLE FOR USE WITH CHILDREN LESS THAN 6 MONTHS OLD.**
- **THE LOWEST RECLINE POSITION SHOULD BE USED TO TRANSPORT BABIES. THE BACKREST CAN BE ADJUSTED TO A MORE UPRIGHT POSITION AS THE CHILD GROWS OLDER AND IS ABLE TO SUPPORT ITS HEAD WITHOUT ASSISTANCE.**

⊙ **TIP:** If the child is sitting in the seat, support the backrest as it reclines. If you have difficulty adjusting the backrest you may need to remove the child from the seat to allow you to raise or lower the backrest with ease.

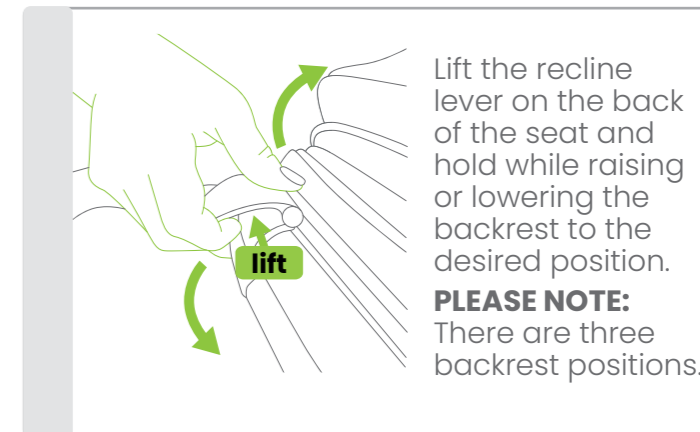

Lift the recline lever on the back of the seat and hold while raising or lowering the backrest to the desired position.

PLEASE NOTE: There are three backrest positions.

Adjusting the Leg Rest

IMPORTANT NOTES:

- The leg rest feature is provided for your child's comfort.
- The leg rest is not designed to support extra weight.
- Do not allow children to stand or sit on the leg rest, it will disengage if extra weight is applied.

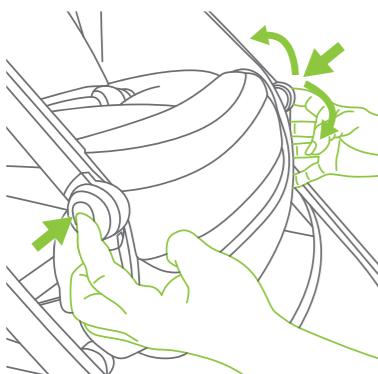

Press the two release buttons on both sides of the leg rest hinge and hold while raising or lowering the leg rest to the desired position.

Adjusting the Handlebar Height

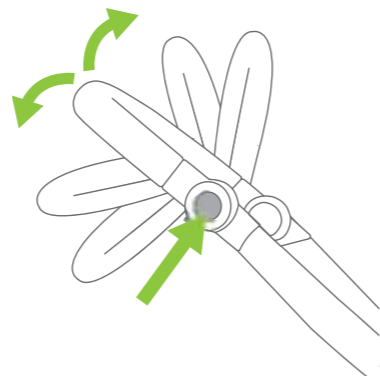

Press the two release buttons on the outside of the handle and hold while raising or lowering the handle to the desired position. When the desired height has been achieved let go of both release buttons.

Securing the Harness

! WARNINGS:

- USE THE HARNESS AT ALL TIMES.
- ENSURE YOUR CHILD IS SECURED WITH A CORRECTLY ADJUSTED HARNESS.
- THE ADJUSTED HARNESS SHOULD CLOSELY FIT THE CHILD.
- NEVER LEAVE THE HARNESS BUCKLED WHEN NOT FITTED TO A CHILD IN THE STROLLER, BECAUSE THE HARNESS CAN FORM LOOPS WHICH MAY POSE A STRANGULATION HAZARD.
- WHEN HARNESS IS NOT IN USE, DISCONNECT SHOULDER STRAPS FROM THE WAIST STRAPS AND BUCKLE TO PREVENT STRANGULATION.
- A five-point harness is provided to restrain your child.
- Buckle tongues separate for added safety.
- To reconnect buckle tongues and to secure the child in the harness please follow the steps to the right carefully.

PLEASE NOTE: Each waist buckle tongue has a raised rib on one side and can only be locked into the buckle assembly with the raised rib facing up. Ensure the harness straps are not twisted as they may become uncomfortable for the child.

A

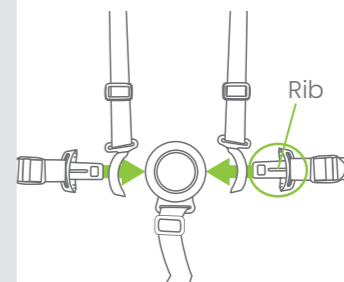

Always apply the brakes before placing child in the stroller seat. Position the shoulder strap near the child's shoulder and position crotch strap between legs. Thread the waist strap buckle tongues through the shoulder straps tongue guides.

B

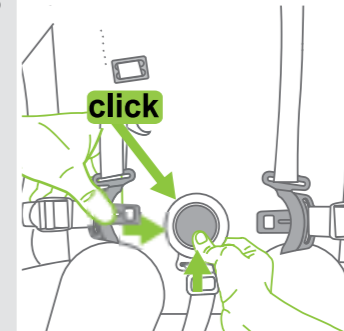

Hold the centre button in on the crotch buckle and insert the waist buckle tongues into the crotch strap buckle until you hear a 'click'. Repeat the procedure on the other side. Please ensure it is locked.

Adjusting the Harness

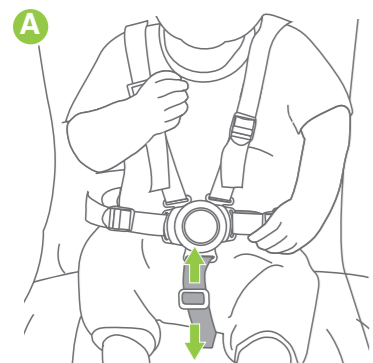

A. Tighten or loosen the crotch strap by sliding the harness adjuster up or down to the desired fit. Note: The crotch strap should be adjusted to a snug fit.

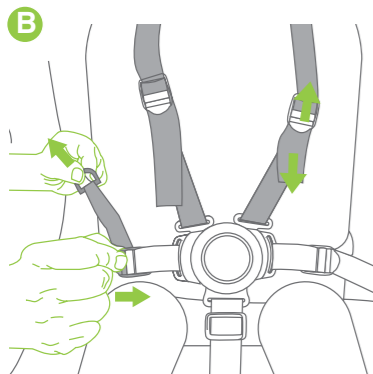

B. Tighten or loosen the waist and shoulder straps by sliding the harness adjuster to the desired fit. Note: The straps need to fit firmly around the child.

Adjusting the Harness Height

IMPORTANT NOTE: The harness can be adjusted to different heights to accommodate the child. The shoulder straps must be positioned near the child's shoulders.

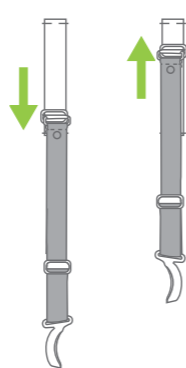

To change the shoulder harness height, simply hold the shoulder harness and slide up and down to the desired position.

Releasing the Harness

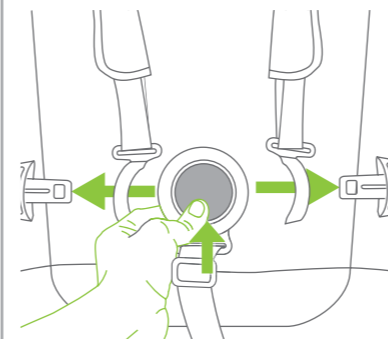

Press the centre of the buckle to release all straps at once.

Storage Basket

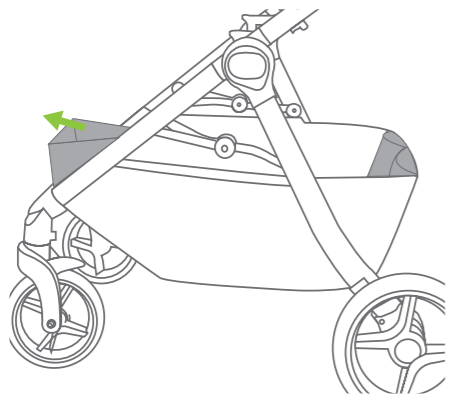

Front basket pull out function for easy access, and storage pockets.

IMPORTANT NOTE:

- Do not place more than 12 kg in the basket at single mode or 4 kg at tandem mode.

Using the Tether Strap

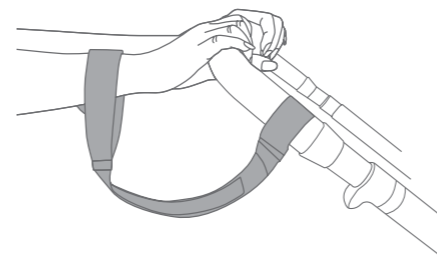

A wrist tether strap is provided on the handle grip. Slide your hand through the tether strap loop whenever you use the stroller. Only remove your hand from the tether strap loop when the brakes have been applied to the stroller wheels.

! WARNINGS: USE THE TETHER STRAP TO STOP THE STROLLER ROLLING AWAY.

- THE STROLLER IS DESIGNED FOR USE ON FLAT OR GENTLY SLOPING SURFACES, AND MAY BE UNSTABLE ON HIGHER SLOPING AND UNEVEN SURFACES AND USERS SHOULD BE AWARE OF THE POSSIBILITY OF THE STROLLER ROLLING AWAY OR TIPPING OVER.
- NEVER LET GO OF THE STROLLER WHEN PARKED ON AN INCLINE OR SLOPING SURFACE BECAUSE IT MAY SLIDE OR TIP OVER. ALWAYS PARK ON A FLAT SURFACE AND APPLY THE BRAKES.
- ALWAYS APPLY THE BRAKES WHENEVER THE STROLLER IS STATIONARY.

Stroller Operation

Removing & Reversing the Seat Unit

IMPORTANT NOTE:

- Always remove your child from the stroller seat before installing, removing or changing the seat direction.
- The maximum weight of the child using this stroller in parent facing mode is 15kg and 20kg in world facing mode.

ⓘ **TIP:** The seat is reversible so it can be attached to the frame in Parent or World facing modes.

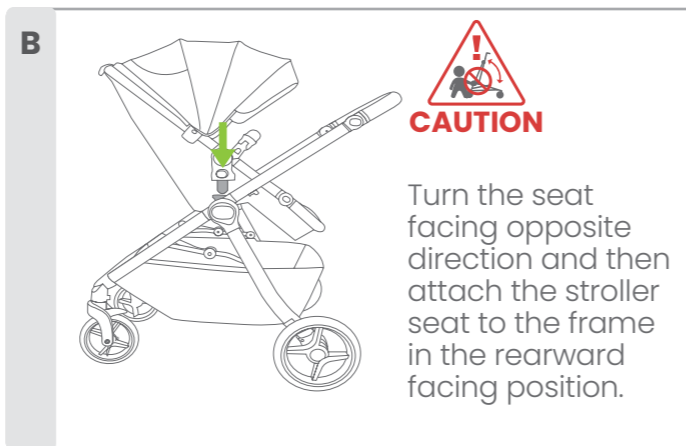
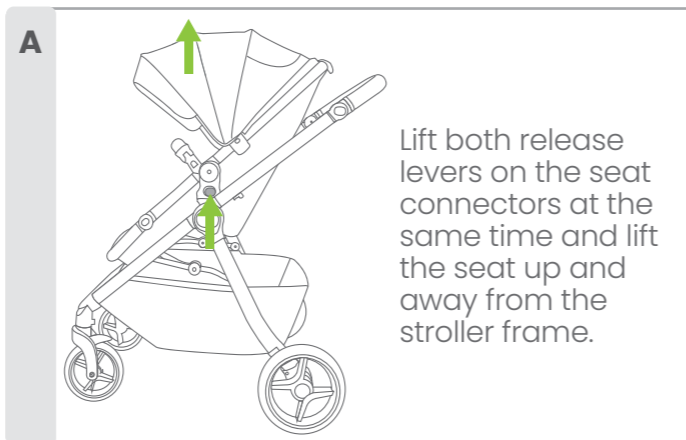

Stroller Operation

Using the Stroller

PLEASE REFER TO PAGE 6 FOR SMART LIFTING TECHNIQUES.

- Always ensure you bend your knees where appropriate and take due care when lifting the frame.
- With your hand through the wrist tether strap loop, push the stroller holding the handle.
- The stroller can be steered in the desired direction - allowing the front wheels to swivel will make this easier.
- The front wheels may wobble or oscillate when walking fast, locking the front swivel wheels will stop this.
- The stroller can be taken up kerbs by either pressing down on the handles and raising the front wheels or turning the stroller around and pulling the stroller up the kerb.
- Caution is required when pushing the stroller on a steep slope as the stroller may become unstable. Always hold the handle firmly.
- Do not run with the stroller.
- Whenever you stop, always apply the brakes before you leave the stroller.
- Do not hang bags on the handlebar or on the back of the backrest unless these accessories are supplied with the stroller or sold as accessories for the stroller. Any load attached to the handlebar and / or on the back of the backrest will affect the stability of the stroller. Use storage basket instead.

Stroller Operation

Folding the Stroller

PLEASE REFER TO PAGE 6 FOR SMART LIFTING TECHNIQUES.

IMPORTANT NOTES:

- Engage the brake.
- Remove the child/children from the stroller.
- Remove the Baby Capsule, Bassinet or Second Seat.
- Ensure the seat backrest is upright and in World facing mode if you fold the stroller with the main seat attached.
- Close canopy to avoid damage when folding.
- Fold the stroller slowly and be careful where you place your hands.
- When folding the stroller, be aware of the danger of being injured by moving parts and locking devices during the process. Keep all hands and limbs clear of these parts.
- There is potential for fingers or parts of the body to be injured when the stroller is being folded, due care should be exercised.
- Keep children clear of the stroller when folding.
- Ensure the frame lock latch is engaged before lifting or carrying the stroller.

FOLDING TIPS

- For easier handling, it is recommended to remove the stroller seat from the frame before folding. Alternatively, the stroller can be folded with seat attached in the World facing position only.
- Ensure the handlebar height is aligned with the frame to prevent it from coming in contact with the wheels and to allow for self standing fold.
- For a more compact fold, ensure the footrest is folded in.
- To fit in smaller cars, it may be convenient to remove the rear wheels.

Stroller Operation

Folding the Stroller

A

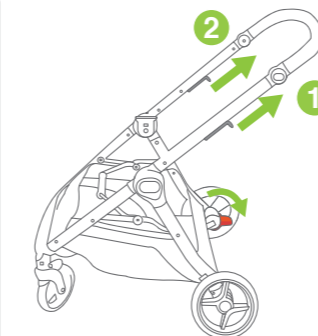

Pull up the folding levers 1 & 2 and begin to push the handlebar down to fold.

B

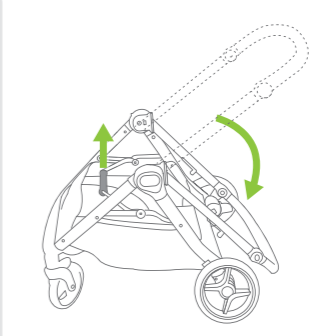

Continue folding all the way down until frame is fully folded and frame lock is engaged.

C

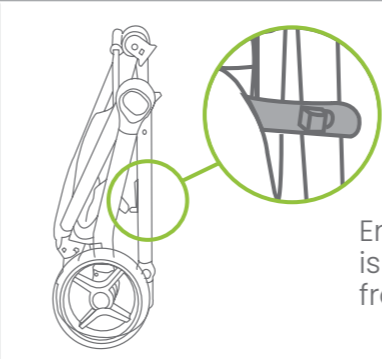

Ensure the frame is securely locked from the inside.

Lifting & Carrying the Stroller

IMPORTANT NOTE:

PLEASE REFER TO PAGE 6 FOR SMART LIFTING TECHNIQUES.

- **To avoid injury: bend your knees when opening, lifting, carrying, folding, unfolding or adjusting the stroller or any accessories.**
- **To avoid damage, do not place heavy objects on top of the folded stroller.**
- **Ensure that the lock latch is engaged when lifting or carrying the stroller.**

Stroller Accessories (Included)

Installing the Seat Liner

IMPORTANT NOTES:

- Ensure that the shoulder and waist harness straps are fitted through the liner harness slots and are adjusted to a snug fit.

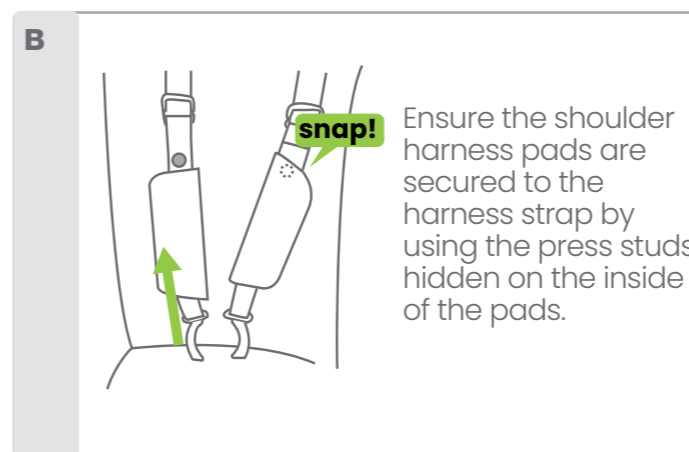
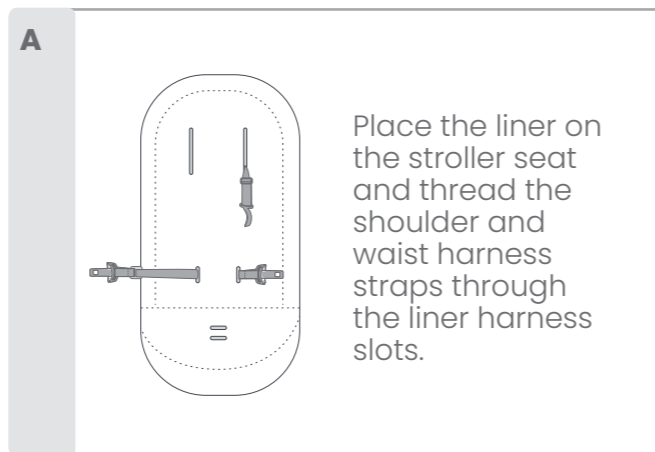

Stroller Accessories (Included)

Stroller Accessories (Sold Separately)

One2 Second Seat

Includes Second Seat, Rear Wheel Guards and Seat Extenders.

PLEASE NOTE: These instructions are for installing and removing the second seat on the stroller only. For proper use of the second seat, please follow the instructions manual provided with the second seat.

! WARNINGS:

- SECURE THE CHILD IN THE HARNESS AT ALL TIMES.
- DO NOT USE ANY ACCESSORIES OTHER THAN THOSE APPROVED FOR USE WITH THIS STROLLER BY BRITAX.
- IT IS UNSAFE TO USE ACCESSORIES NOT APPROVED FOR USE WITH THIS STROLLER.
- THE MAXIMUM WEIGHT OF THE CHILD USING THIS SECOND SEAT IS NOT TO EXCEED 15KG.

IMPORTANT NOTES:

- Do not use this second seat with any other models of stroller.
- The second seat must be correctly fitted and locked onto the stroller frame.
- The second seat can only be used in the World facing position, connected to the rear of the stroller.
- Do not overload the stroller. Overloading will cause the stroller to tip backwards.

One2 Second Seat Attaching the Rear Wheel Guards

SAFETY WARNING: Before using the second seat, the wheel guards must be installed.

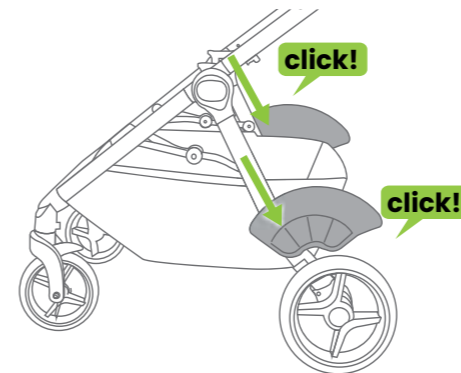

Slide each guard onto the mounting bracket above each rear wheel housing and push down until it locks into place. There is left and right wheel guards.

Stroller Accessories (Sold Separately)

One2 Second Seat Attaching & Removing the Seat Extenders

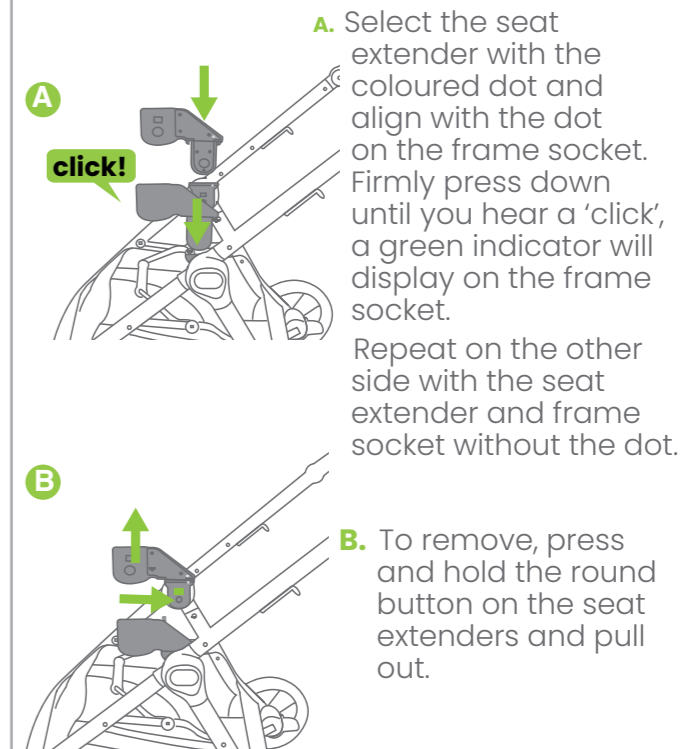

A. Select the seat extender with the coloured dot and align with the dot on the frame socket. Firmly press down until you hear a 'click', a green indicator will display on the frame socket.

Repeat on the other side with the seat extender and frame socket without the dot.

B. To remove, press and hold the round button on the seat extenders and pull out.

Attaching the Second Seat Unit

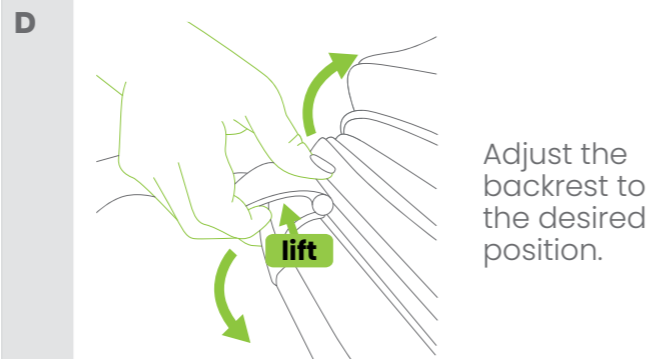
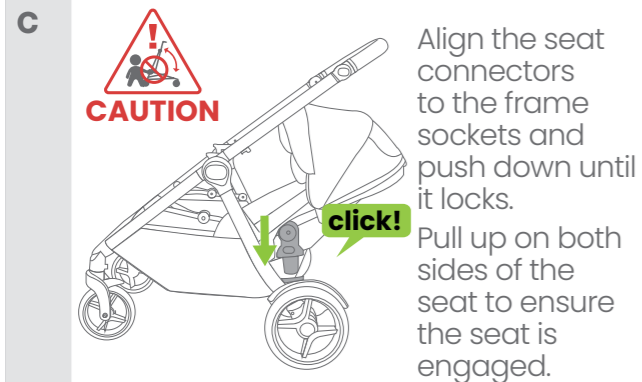
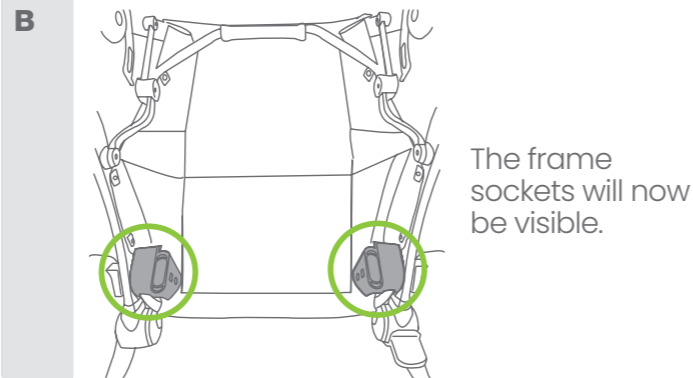
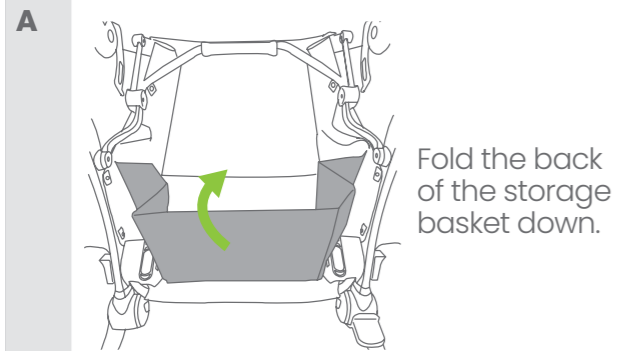

Removing the Second Seat

IMPORTANT NOTE:

- Always remove your child from the seat before removing the second seat.
- Always remove the second seat before folding.

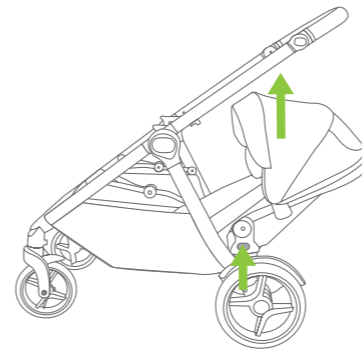

Lift both release levers on the seat connectors at the same time and lift the seat up and away from the stroller frame.

Stroller Accessories (Sold Separately)

Baby Capsule

WARNINGS:

- IT IS UNSAFE TO USE ACCESSORIES NOT APPROVED FOR USE WITH THIS STROLLER
- DO NOT USE ANY ACCESSORIES OTHER THAN THOSE APPROVED FOR USE WITH THIS STROLLER BY BRITAX.
- DO NOT EXCEED THE MAXIMUM WEIGHT CAPACITY ON THE BABY CAPSULE*.

IMPORTANT NOTES:

- The Britax One2 stroller is only compatible with the Britax and selected competitor baby capsules.
- Only use baby capsules that are compatible to fit to this stroller. For detailed compatibility refer to:

Australia:
britax.com.au



New Zealand:
britax.co.nz



- Remove the stroller seat, bassinet or second seat from the stroller frame before installing the baby capsule.
- The baby capsule must be correctly fitted and locked onto the frame.
- On the top seat position the baby capsule can only be used in the Parent facing mode.
- On the second seat position the baby capsule can only be used in the World facing mode.
- Secure the child using the baby capsule harness at all times.
- Do not leave the child in the baby capsule for extended periods.
- The baby capsule is designed to provide mobility outside of the car, it should not be used instead of an appropriate cot.
- The baby capsule and or second seat must be removed from the stroller frame before folding.
- The sun is very strong. Do not leave your child exposed to the sun. The canopy or hood on this product will not give your child total protection from the harmful rays of the sun.

Stroller Accessories (Sold Separately)

Baby Capsule Adaptors

Installing & Removing the Britax Click & Go™ Baby Capsule Adaptors One2

WARNINGS:

THE BABY CAPSULE ADAPTORS MUST BE ATTACHED TO THE STROLLER FRAME BEFORE INSTALLING THE BABY CAPSULE.

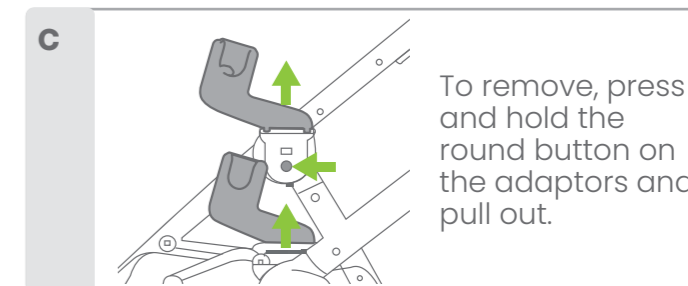
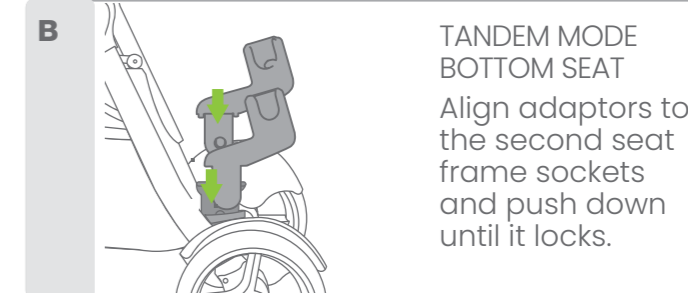
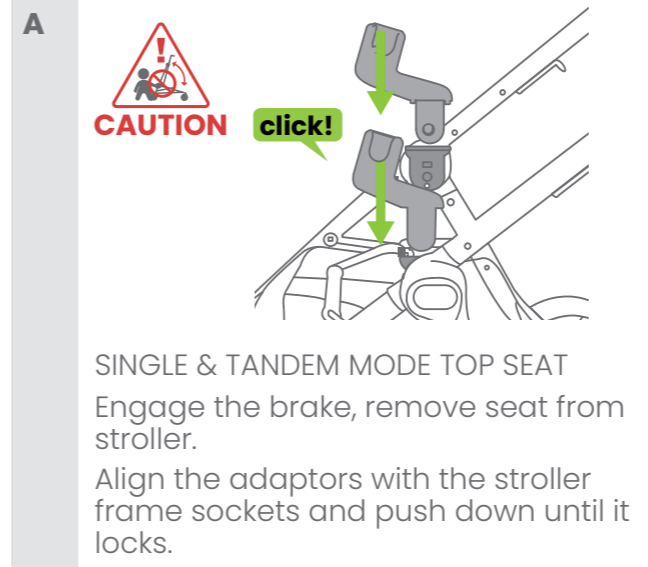

Note: The adaptors can be used on the top or second seat.

Baby Capsule

Installing the Britax Baby Capsule

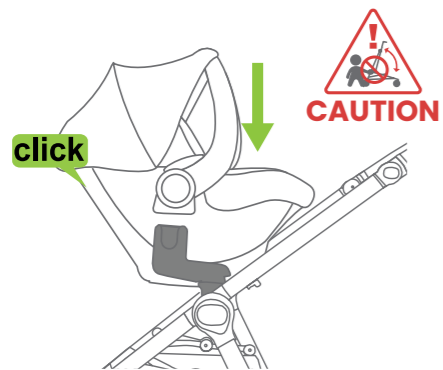

SINGLE & TANDEM MODE TOP SEAT

Engage the stroller brake. Align the baby capsule with the adaptors and press down firmly until you hear a 'click'. Pull up the baby capsule to ensure it is locked into the stroller frame.

Note: The baby capsule must be on Parent facing mode (facing the stroller handlebar).

Installing the Britax Baby Capsule

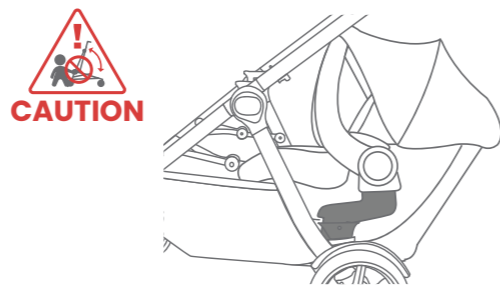

TANDEM MODE BOTTOM SEAT

Engage stroller brake. Align the baby capsule to the adaptors on the bottom seat and press down firmly until you hear a 'click'.

Note: The baby capsule must be in World facing mode (facing the front wheels).

Baby Capsule

Removing the Britax Baby Capsule

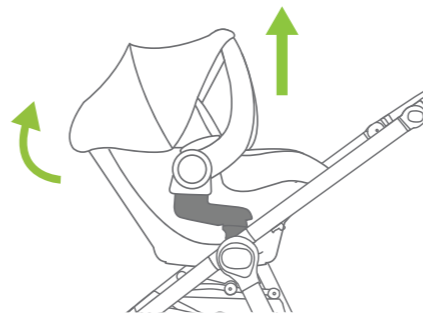

Engage the brake. Pull and hold the release lever on the back of the baby capsule and lift to remove from stroller.

PLEASE NOTE: These instructions are for installing and removing the baby capsule on the stroller only.

- For installing and proper use of the baby capsule in the car, please follow the instructions manual provided with the baby capsule.
- Ensure the baby is secured in the baby capsule with the harness at all times. Refer to the baby capsule instruction manual regarding placing and securing your baby in the baby capsule.
- For attaching or removing competitor baby capsules refer to instruction manual provided with the baby capsule.

Stroller Accessories (Sold Separately)

Rain Cover

IMPORTANT NOTES:

- Ensure rain cover is kept away from the child's face.
- Refit rain cover if required to ensure child is safe.

☑ **TIP:** The rain cover can be used in both single and tandem modes. An extension panel is also provided which is easily secured to the single mode rain cover with a zip.

Using the Extension

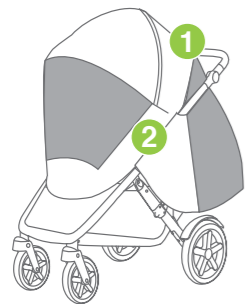

Attach the rain cover extension as required and secure to the rain cover with the zipper (1) and hook & loop (2) attachments.

Accessing your child

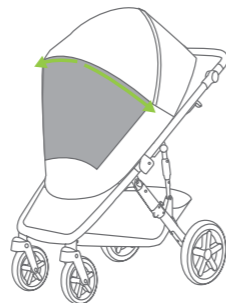

Open zipper (dashed orange line) to access the baby.

Attaching the rain cover

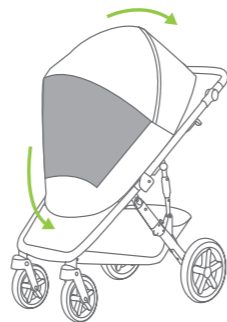

Pull the front elastic section of rain cover over the leg rest. Ensure the rain cover fits snugly over the canopy and is securely fitted to stroller seat.

Sun Cover

Attaching the Sun Cover



A. Fit the sun cover over the canopy front and secure the toggle and elastic loop around the canopy frame then pull to the front and secure with the elasticised end.

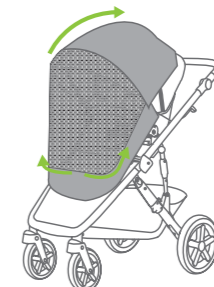

B. Lift the sun cover flap to use mesh panel for ventilation and open zipper to access the baby.

Cup / Bottle Holder

Attaching the Cup / Bottle holder

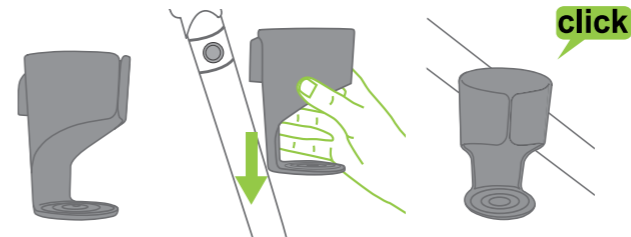

The cup / bottle holder can only fit on the right-hand side of the frame. Push the cup / bottle holder attachment to the connector on the frame.

IMPORTANT NOTES:

- Do not place over 1kg in the cup / bottle holder.
- Do not place hot drinks in the cup / bottle holder.
- Remove contents from the cup / bottle holder before folding the stroller.

Stroller Accessories (Sold Separately)

Stroller Accessories (Sold Separately)

Newborn & Toddler Comfort Pack

IMPORTANT NOTES:

- This insert is not suitable for the One2 Second Seat.
- Do not use the newborn back support wedge on the One2 stroller. The wedge is designed to provide extra back support for newborns when the seat does not have a complete lay flat recline / bassinet mode.
- The head pillow and the insert can be used on bassinet or seat mode until the toddler years to provide extra comfort and support.
- Ensure that the shoulder and waist harness straps are fitted through the insert harness slots and are adjusted to a snug fit.

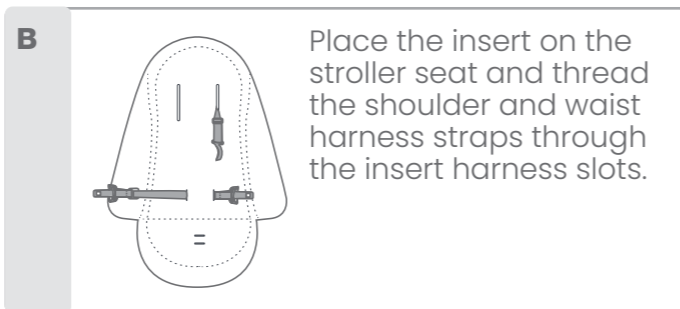
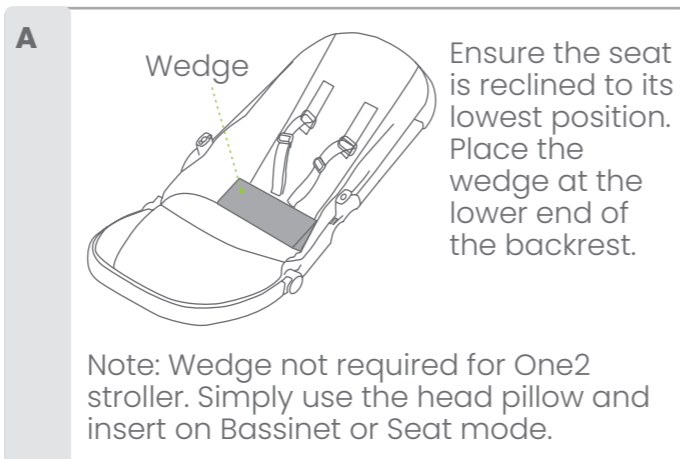

Stroller Accessories (Sold Separately)

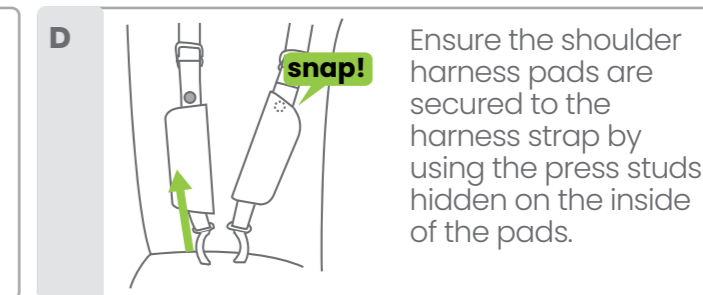
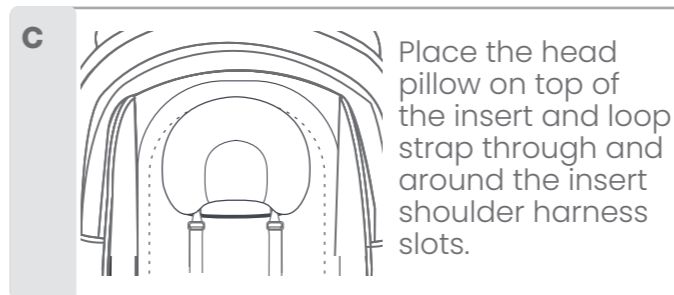

Care & Maintenance

General Maintenance & Repair

- Ensure all safety devices, locks, harness, and brakes are in working order.
- Ensure all joints and folding areas move freely as intended.
- Should any moving or locking parts become stiff or hard to operate, ensure these are free from tension, or dirt by wiping clean with a damp cloth to remove any dirt, sand, or debris. Allow to dry and lightly spray with a dry silicon lubricant. Please carefully read the lubricant instructions prior to use.
- Ensure wheels are regularly cleaned with a damp cloth by removing dirt, sand, or debris. Allow to dry and lightly spray the wheel pivot pin with a dry silicon lubricant to keep the wheels moving smoothly. Please carefully read the lubricant instructions prior to use.
- Regularly spray all moving parts with a dry silicon lubricant. Please carefully read the lubricant instructions prior to use.
- Ensure all connecting rivets and screws are secure. Tighten if required.
- If there are compression marks on the tyres, use a domestic hair dryer to gently warm (DO NOT OVERHEAT) the tyre and the compression marks should slowly disappear.
- To maintain the safety and longevity of the

stroller, seek prompt repairs or replacement for bent, torn, worn, or broken parts. Do not continue to use the stroller if unsafe.

- All repairs should only be carried out by an authorised Britax repairer. Only Britax replacement parts should be used with the stroller. It may be unsafe to use parts supplied from another manufacturer.

General Tips

Do not store the stroller in your car for prolonged periods of time during summer as it may lead to damage to some of the plastics components.

Do not leave the stroller in direct sunlight for extended periods of time, as colours of some fabrics may fade, and tyres may deteriorate.

Do not fold or store the stroller if damp or wet, as fabric may develop mould or mildew. Always store the stroller inside in a dry, well-ventilated area.

Do not place heavy objects on top of the stroller as it may alter the shape.

Should you have any further questions on care & maintenance of the stroller, please contact our Consumer Service Team at: aunz-support@britax.com

Care & Maintenance

Cleaning

Fabrics

- Removable fabrics may be cleaned using lukewarm water and soap or mild detergent. Rinse thoroughly and allow to dry away from direct sunlight.
- Non-removable fabrics can be spot cleaned using a damp sponge and soap or mild detergent. Allow to dry completely before re-use or storage.
- Never use bleach, or abrasive cleaning products.
- **DO NOT** iron or dry clean.

NOTE: DO NOT place any of the stroller fabrics in the dryer. Allow to dry naturally, away from direct sunlight.

Frame

- Remove dirt and dust away from any moving mechanism.
- Clean frame with a soft damp cloth and soap or mild detergent and allow to dry thoroughly.
- **DO NOT** use abrasive cleaning products as it may cause stains, discolouration or scratches to the frame.
- **DO NOT** soak or submerge frame in water.
- **DO NOT** remove, dismantle or alter any part of the stroller mechanism or brakes.

Leatherette

- Spot clean with a damp soft cloth.
- **DO NOT** use a dripping wet cloth or wet the leatherette excessively.

Wheels

- Remove wheels from stroller.
- Clean with damp cloth and soap or mild detergent. Use brush to remove dirt and mud build up around the tyre. Allow to dry thoroughly before placing wheels back on the frame.
- If necessary lubricate wheel shaft with a small amount of lubricant before placing into the stroller.
- Ensure the stroller is cleaned thoroughly after using it on the beach as sand and salt can damage stroller mechanism, wheel assembly, causing premature wear and corrosion.

PLEASE NOTE:

Our product warranty does not cover any rust to the rivets or screws, if you are caught in the rain or at the beach always thoroughly dry the frame to avoid any rust damage.

Care & Maintenance

Just like servicing your car or bicycle, prams and strollers also need **regular maintenance checks**. These checks can improve product performance, extend the life of your stroller and help to provide you and your children a safe and smooth journey.



We recommend servicing your stroller every 6 months and completing an inspection once a month. To prolong the life of your stroller, a regular maintenance should be performed.

5 STEP CHECK LIST

1. **INSPECT SAFETY DEVICES** tether strap, frame lock, harness, buckle and brakes, and ensure all are in working order and free from dirt, sand, and debris.
2. **INSPECT** all connecting rivets and screws are secure.
3. **MAKE SURE FOLDING JOINTS** are free of dirt, dust, and debris by cleaning with a damp cloth, allow to dry and lightly spray with a dry silicon lubricant. Please carefully read the lubricant instructions prior to use.
4. **REMOVE WHEELS** and wipe clean with a damp cloth to remove any dirt, sand or debris. Allow to dry and lightly spray the wheel pivot pin with a dry silicon lubricant to keep the wheels moving smoothly. Please carefully read the lubricant instructions prior to use.
5. **ENSURE WHEN FOLDING AND STORING** to wipe down your stroller frame and allow to dry before storing in a dry place without direct sunlight.

Australian Consumer Law

On all of our goods, you have the benefit of a statutory consumer guarantee. In summary, goods are guaranteed to be of “acceptable quality” (fit for purpose), goods are guaranteed to match any sample against which they are sold. These consumer guarantees are provided for by the Australian Consumer Law and, if you believe any one of these guarantees is not satisfied by a Britax product, you have rights under the Australian Consumer law to enforce that guarantee.

Your rights under the statutory consumer guarantees are set out in the **Australian Competition and Consumer Commission’s Consumer Guarantees – A Guide for Consumers**.

In addition to the statutory consumer guarantees, **Britax** offers its own company warranty on all of its products. You therefore have the option of seeking redress for defective or faulty product either under the **Britax** company warranty or the statutory guarantees.

After the **Britax** company warranty expires, you still have your rights under the statutory consumer guarantees.

International Warranty

Britax products are available through a network of retailers in Australia and New Zealand. If you are an international customer we do not offer a warranty service outside of these regions.

THIS PRODUCT IS NOT INTENDED FOR COMMERCIAL USE

Warranty

Did you know?

Registering your product online simplifies proof of purchase in the event of a warranty claim.

Head to our website to fill out the product registration form:

britax.com.au **britax.co.nz**



Making A Warranty Claim

Your rights under a **Britax** company warranty are separate from and independent of your rights under the statutory consumer guarantees. What you need to do to enforce your rights under a statutory consumer guarantee is set out in the

Australian Competition and Consumer Commission's Consumer Guarantees – A Guide for Consumers.

To make a claim under a **Britax** company warranty, please contact our customer service team on:

Australia: 1300 303 330 / **New Zealand:** 0508 688 822 *or* alternatively by email at: **aunz-support@britax.com**

You will be required to :

- Return the product to the place of purchase or to a designated repair agent;
- Present your receipt as proof of purchase;
- Identify the defect in the product; and
- Present the product to **Britax** for inspection on request.

Britax will advise you whether the product is covered by the **Britax** company warranty. **Britax's** decision of whether a product is covered by a **Britax** company warranty is final. **Britax** will act reasonably when determining whether a product is covered by a company warranty.

Series No. RM-S287T
Art No. 4002416_C

Britax Childcare Pty. Ltd.

A.B.N. 55 006 773 600

Level 4, 650 Lorimer Street, Port Melbourne, Victoria 3207, Australia

Phone: (03) 9288 7288 **Fax:** (03) 9311 5798

Customer Service

Australia: 1300 303 330 / New Zealand: 0508 688 822

Due to our continuing program of development, Britax reserves the right to alter the specifications, color or design without any further notice.

The **Britax** trademark is the property of Britax Childcare Holdings Limited - UK.

Visit the **Britax** website at: **britax.com.au or britax.co.nz** or email us at **aunz-support@britax.com**

Due to the variations in the style and design of our products the illustrations used in this instruction booklet are generic.

This product is designed to comply with **Australian Standard AS 2088:2022**

“Prams and Strollers- Safety Requirements”

Copyright © 2021 Britax Childcare Pty. Ltd. Australia