



# 360° Swivel Convertible Child Seat

0<sub>YRS</sub>  
—  
4<sub>YRS</sub>

**IMPORTANT:**  
KEEP THIS BOOKLET IN THE PLACE  
PROVIDED ON THE CHILD RESTRAINT

# Contents

## Set Up

QUICK START GUIDE	
• REARWARD FACING MODE	04
• FORWARD FACING MODE	09
MEET YOUR CHILD SEAT	14
IMPORTANT INFORMATION AND WARNINGS	16
SHOULDER HEIGHT MARKERS	18
OUTGROWN YOUR CHILD SEAT	22
CHILD SEAT SUITABILITY GUIDE	23

## Rearward Facing

CHILD SEAT FEATURES - REARWARD FACING	24
SETUP	
GENERAL INFORMATION	26
INSTALLING INTO YOUR VEHICLE	27
TOP TETHER	32
CROTCH STRAP	35
HEADREST AND SHOULDER HARNESS	36
REMOVE CHILD FROM CHILD SEAT	41
REMOVE CHILD SEAT FROM VEHICLE	42



REARWARD FACING  
INSTALLATION VIDEO

## Care and Maintenance

CARE AND MAINTENANCE	60
CLEAN HARNESS BUCKLE	61
• REMOVE COVER	63
• REPLACE COVER	65
• ACCESSORIES	68
INSTALLATION OF VEHICLE UPPER ANCHOR POINT	71
IN CASE OF ACCIDENT	76
WARRANTY	78

## Forward Facing

CHILD SEAT FEATURES - FORWARD FACING	44
SETUP	
GENERAL INFORMATION	46
INSTALLING INTO YOUR VEHICLE	47
TOP TETHER	50
HEADREST AND SHOULDER HARNESS	53
REMOVE CHILD FROM CHILD SEAT	57
REMOVE CHILD SEAT FROM VEHICLE SEATBELT	58



FORWARD FACING  
INSTALLATION VIDEO

**1.** Check child seat is right for your child

Use rearward facing when shoulder below the middle height marker registration.

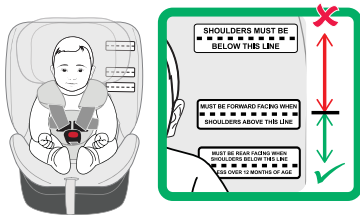

**1.1** Pre-Check Harness Height

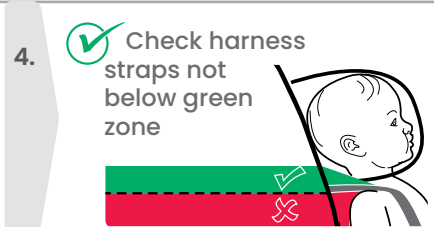
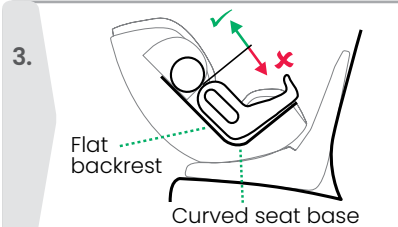

**1.2** Pre-Check Crotch Strap Position

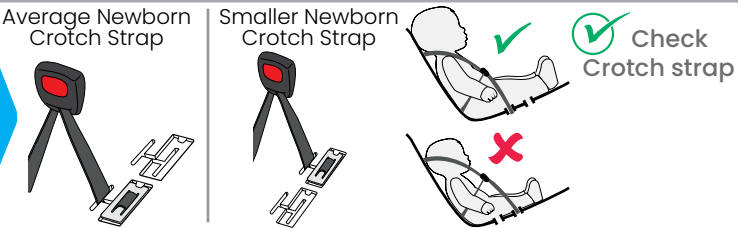

**2.** Attach seatbelt

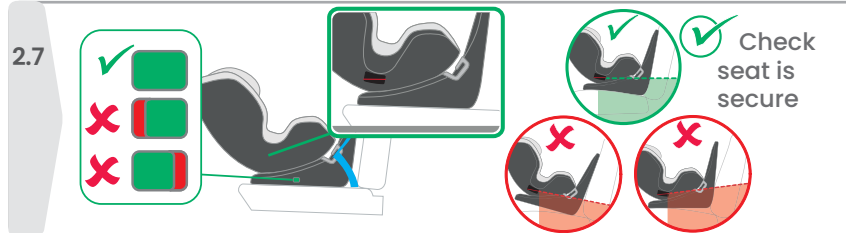
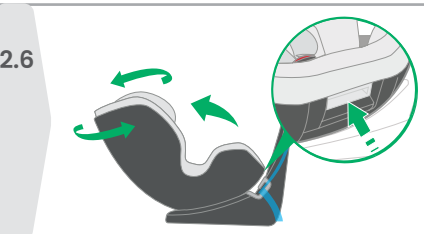
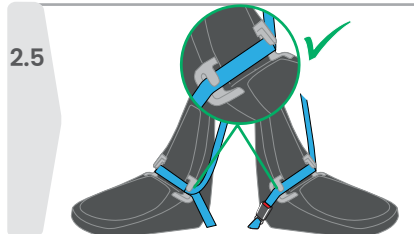
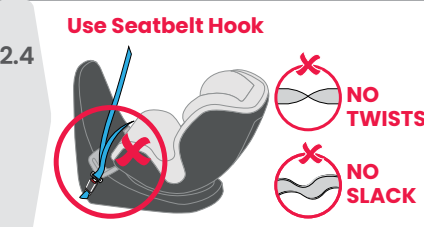
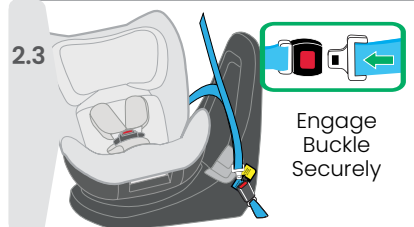
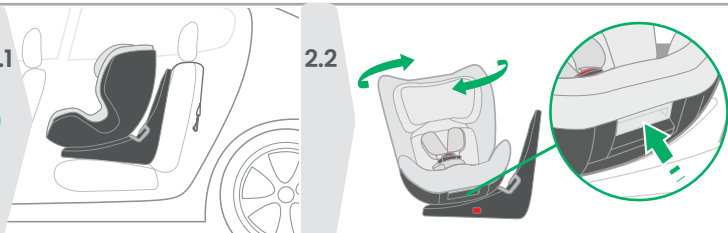

**3. Attach Top tether**

3.1



3.2

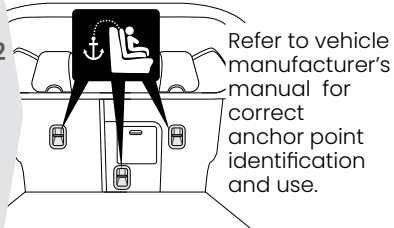

3.3

Lengthen strap



3.4

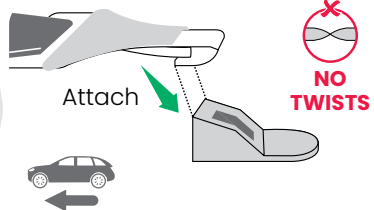

3.5

Pull to tighten

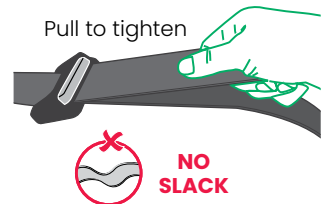

3.6



3.7



✓ Check top tether is secure

**4. Secure the Child**

4.1

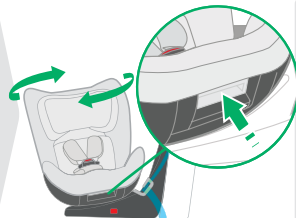

4.2

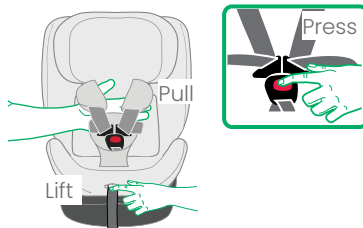

4.3

Place infant in seat

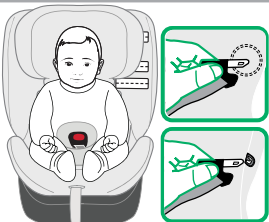

4.4

✓ Check harness straps not below green zone

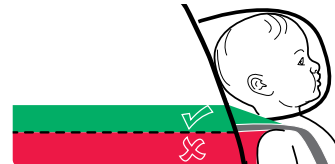

4.5

✓ Check Crotch Strap Height

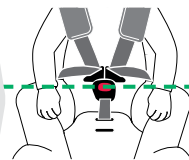

4.6

Engage Tongues

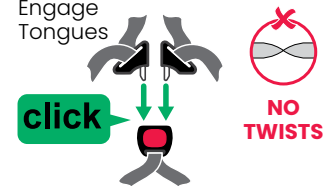

4.7

Tighten harness firmly

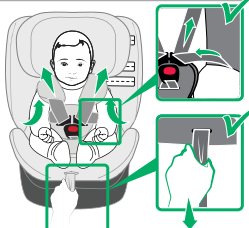

4.8

Rotate seat to Rearward Facing latched position

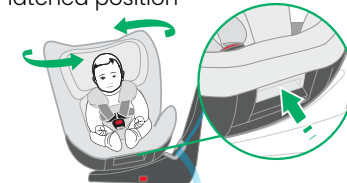

4.9

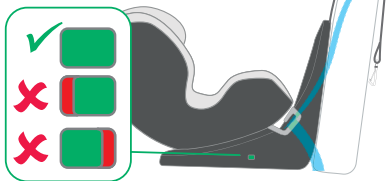

✓ Check Rotation Indicator

1. Check child seat is right for your child

Use forward facing when shoulder is above middle height marker registration.

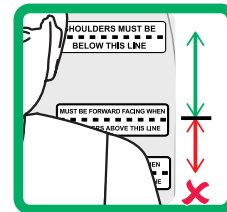

1.1 Pre-Check Harness Height

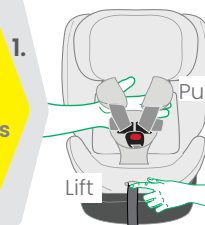

3.

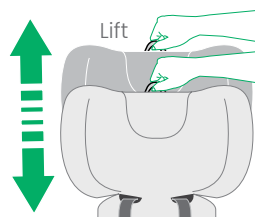

4.



✓ Check harness straps not below green zone

1.2 Pre-Check Crotch Strap Position

Crotch Strap

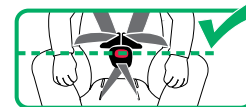
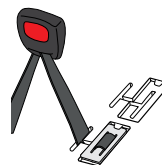

✓ Check Crotch strap

**2. Attach seatbelt**

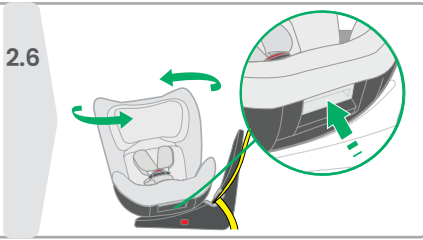
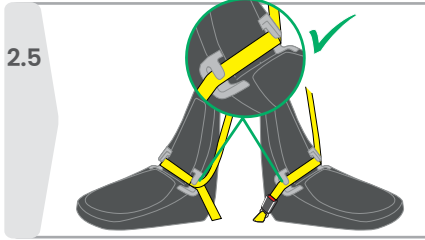
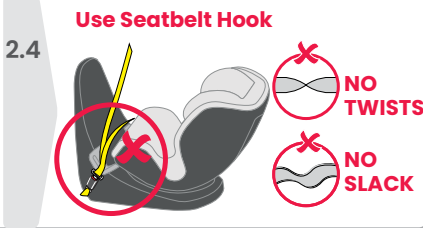
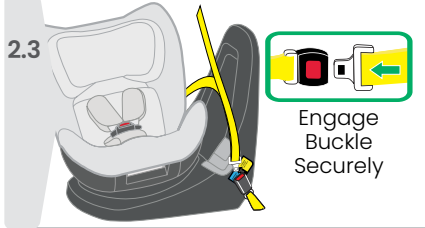
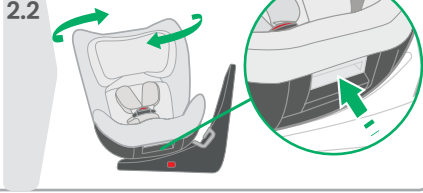
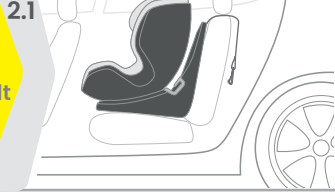

**3. Attach Top tether**

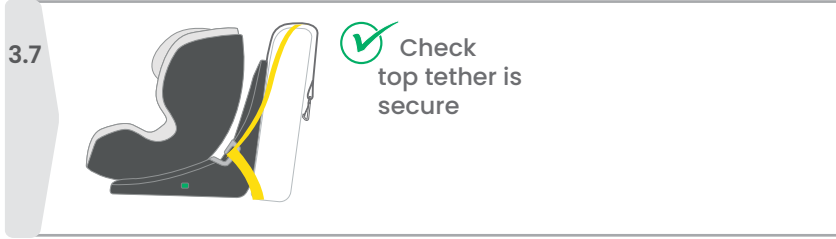
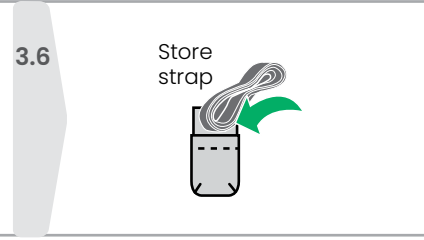
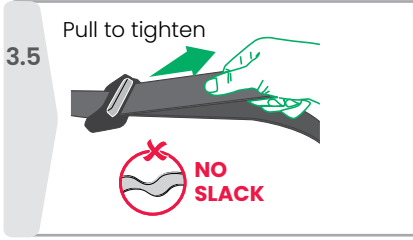
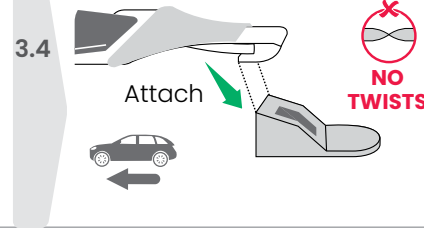
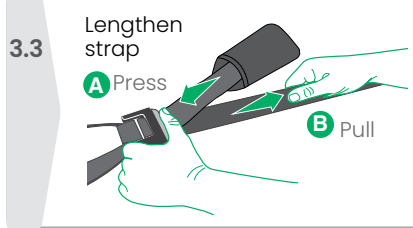
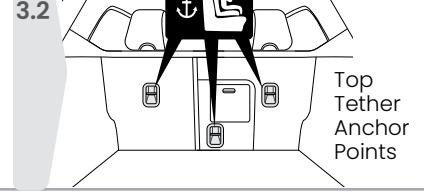
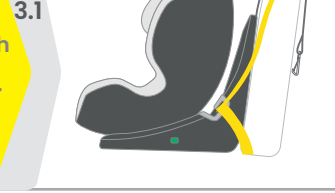

**4. Secure the Child**

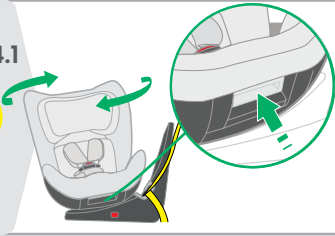
4.1 

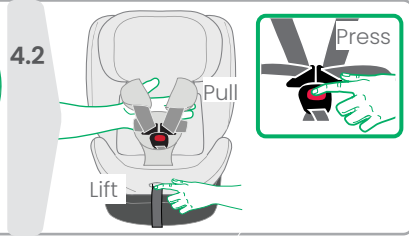
4.2 

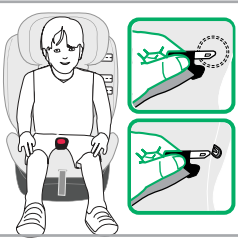
4.3 **Place child in seat** 

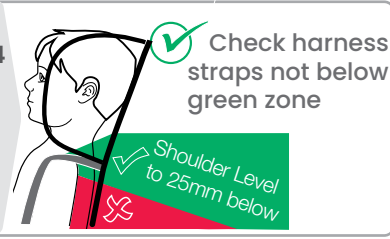
4.4  **Check harness straps not below green zone**  
 ✓ **Shoulder Level to 25mm below**

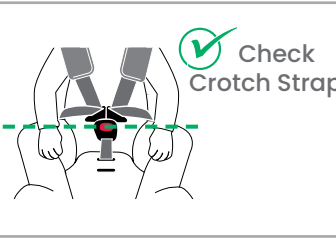
4.5  **Check Crotch Strap**

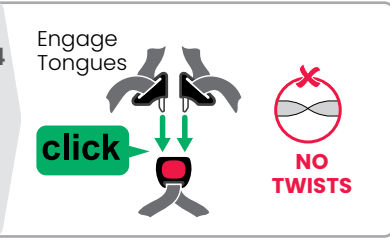
4.4 **Engage Tongues**  **click**  
**NO TWISTS**

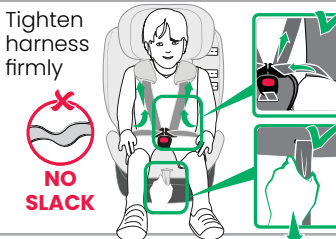
4.6 **Tighten harness firmly**  **NO SLACK**

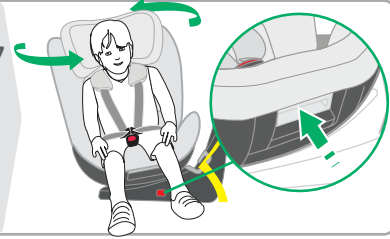
4.7 

4.8  **Check Rotation Indicator**

## Meet Your Child Seat

Before installing the child seat, note the serial number found on the seat to complete your warranty registration.

### Rearward Facing

To be used only in a rearward facing position until the child's shoulders either reach the lower shoulder height marker (approximately 12 months of age) or reach the middle height marker (approximately 2 to 3 years of age).

### Forward Facing

Then to be used in a forward facing position until the child's shoulders reach the upper shoulder height marker (approximately 4 years of age).

Continue to use this child restraint until the child reaches this limit.

Do not use forward facing until child's shoulders are above the lower shoulder height marker.

Infants are at risk of serious injury if they face forward too early.

Children are at risk of serious injury if they move to booster seats too early.

Children who have outgrown this restraint are safest in a larger child restraint with an in-built harness or a booster seat until their shoulders reach the upper shoulder height marker of the restraint.

To ensure that your child gets all the protection designed into the restraint PLEASE READ AND FOLLOW THESE INSTRUCTIONS EXACTLY and use only Britax recommended parts and accessories.

If in doubt about the method of installation, consult Britax® Childcare or agent, or a child restraint fitter or, in New Zealand, to consult the agent for the vehicle.

## Meet Your Child Seat

Meet the **BRITAX 360° swivel convertible car seats** – the smart choice for parents who know what they want.

Our premium car seat transitions seamlessly from your 1st trip from hospital through to your child's fourth birthday. The 360° swivel technology maximizes efficiency – perfect for busy parents who value intelligent design.

Switch from rear-facing (up to 36 months) to forward-facing with confidence. Multiple recline positions adapt to your child's developmental needs while you stay in control of every journey.

### Active Headrest Restraint (AHR™)

The Active Headrest Restraint is designed with deeper side wings to shield and protect your child's head in a side impact crash. The Active Head Restraint has an inner Side Impact Cushion Technology layer which provides 180 degree protection around your child's head. The AHR™ is adjustable to grow with your child and works in conjunction with SICT™ to protect your child's head and minimise the force of impact.

## Important Information And Warnings

### **WARNINGS**

- Fit the restraint firmly to the car seat.
- Fit the harness firmly to the child.
- A loose restraint or harness is dangerous.
- Supervision of children is needed because they may be able to undo the buckles and adjusters.
- Use the restraint exactly as shown in the instructions.
- **DO NOT LEAVE CHILDREN UNATTENDED IN THE CAR.**
- Do not alter or modify this restraint.
- Repairs must only be done by the manufacturer or agent.
- Do not allow the restraint to come into contact with polishes, oils, bleach and other chemicals.
- Destroy the restraint if it has been in a severe crash, even if no damage is visible. See page 84 & 85.
- **DO NOT USE THIS RESTRAINT WITHOUT THE COVER.**
- Always secure the loose end of the top tether strap. Do not use the child restraint where this top tether strap may fall into a split in the seat back or off the side of the seat.
- **ALWAYS ATTACH TOP TETHER HOOK AND REMOVE SLACK.**
- To ensure infant's back is evenly supported, do not put more than one nappy on the baby and make sure the nappy is not thickly folded at the back.
- **DO NOT USE A REAR FACING CHILD RESTRAINT WHERE AN AIRBAG IS FITTED IN FRONT OF THE SEATING POSITION.**
- Do not harness an infant wrapped in a blanket or swaddled. Any blanket or wrap must only be placed over the harness and infant.
- Rearward and forward facing child restraints should always be correctly installed, properly adjusted and used as instructed by the manufacturer instructions.
- If your vehicle is not fitted with an anchor point, please contact a Safety Restraint Fitting Station authorised by the relevant State Government Body for correct fitment of the restraint. In New Zealand contact the agent for the vehicle. The top tether strap must be attached to an upper anchorage point using an extension strap if necessary.
- Do not use on any vehicle seat which faces sideways or rearwards.
- This child restraint is not approved for use with any connectors that connect to the car's ISOFIX low anchorages.

## Important Information And Warnings

### **IMPORTANT:**

TO BE USED WITH A LAP-SASH OR LAP-ONLY SEATBELT IN THE BACK OF MOST CARS WITH FORWARD FACING SEATS.

### **GENERAL**

- Always attach the top tether strap to the child restraint upper anchorage in your car.
- Babies and children below 4 years old must not sit in the front seat of a vehicle unless allowable by the Regional Road Rules. Check your Regional Road Rules.
- Protect all webbing from abrasion and cutting by sharp corners and edges.
- The restraint should not be purchased or sold as a second hand item. It is recommended not to use child restraints older than 10 years as the protection in an accident may be reduced.
- **THIS RESTRAINT IS NOT SUITABLE FOR USE WHERE THE TOP TETHER STRAP MAY FALL INTO A SPLIT IN THE SEAT BACK OR OFF THE SIDE OF THE SEAT.**
- Seatbelt extenders are not recommended to be used if the seatbelt is not long enough to secure the child restraint. If seatbelts are too short then seek advice from a child restraint fitter and consider their recommendations before using a seatbelt extender. If you use a seatbelt extender then ensure that the seatbelt buckle does not enter the rearward or forward facing belt paths.
- Ensure babies and toddlers are adequately shaded from direct sunlight through side or rear windows.
- Check the car is ventilated by opening windows or using the car's ventilation system taking in external air. Recirculation setting is not suitable for providing ventilation.
- **THIS RESTRAINT MUST BE ATTACHED TO A CHILD RESTRAINT UPPER ANCHORAGE POINT IN THE CAR. REFER TO CAR OWNER'S HANDBOOK FOR LOCATION OF UPPER ANCHORAGE POINTS. REFER TO A CHILD RESTRAINT FITTING STATION IF NO UPPER ANCHORAGE POINTS ARE IN THE MOTOR CAR. Refer to pages 78 to 82.**

## Shoulder Height Markers

Shoulder height markers are featured clearly on the child seat (as seen in diagram). The markers provide an indicator for when your child has outgrown the child's seat rearward or forward facing modes.

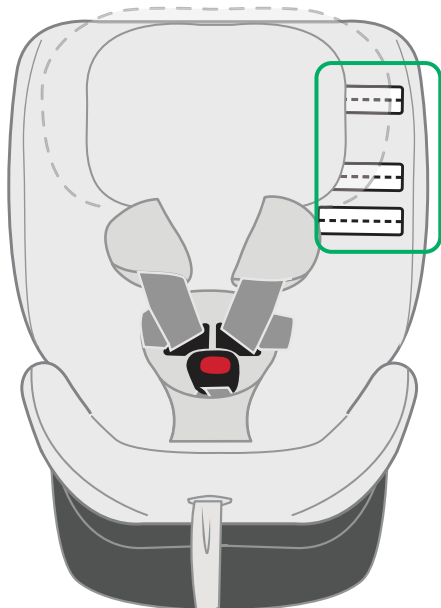

## Shoulder Height Markers

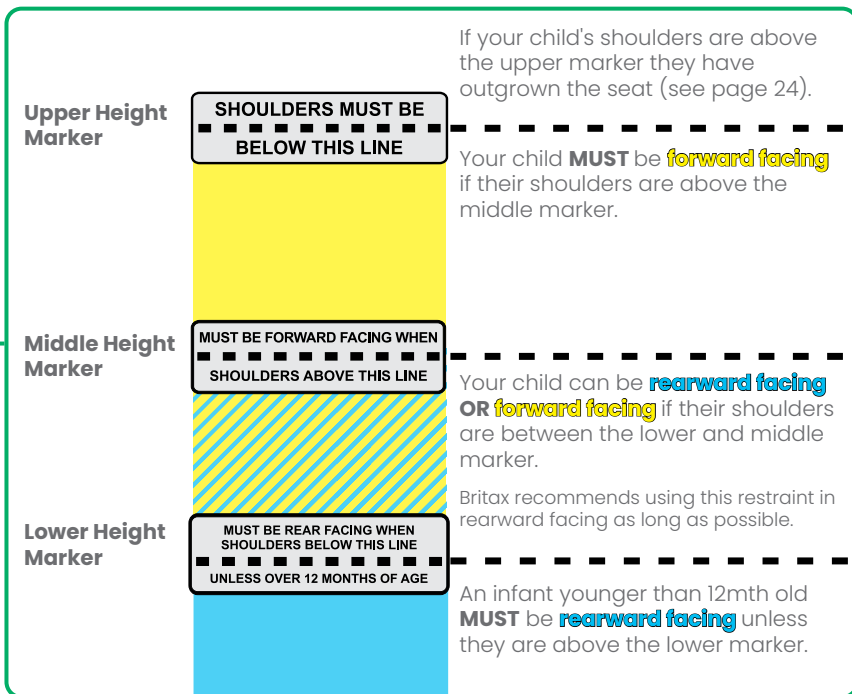

## Shoulder Height Markers

**!** **IMPORTANT:** Follow this advice.

**SHOULDERS MUST BE BELOW THIS LINE**



**MUST BE FORWARD FACING WHEN SHOULDERS ABOVE THIS LINE**

**Older Baby (Rearward Facing)**



Middle Height Marker  
Lower Height Marker

**OR**



Middle Height Marker  
Lower Height Marker

**MUST BE REAR FACING WHEN SHOULDERS BELOW THIS LINE UNLESS OVER 12 MONTHS OF AGE**

**Newborn (Rearward Facing)**

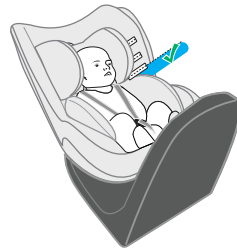

Lower Height Marker

## Shoulder Height Markers

**Child Use (Forward Facing)**



Upper Height Marker  
Middle Height Marker

**Older Baby (Forward Facing)**

## Outgrown Your Child Seat

When your child has outgrown this seat, you can use:



- A harnessed child seat with in-built harness suitable for children **approximately 6 months to 8 years old**.

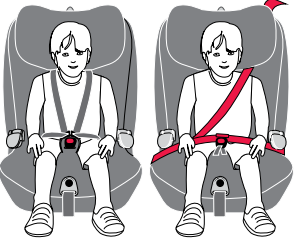

- A convertible booster seat with in-built harness until **approximately 4 years old** and then as a booster seat with vehicle lap-sash seatbelt until **approx 6 to 8 years of age** (or seatbelt and compatible child harness).



- Or a dedicated booster seat with vehicle lap-sash seatbelt until **6 to 8 years of age or until 8 to 10 years of age** (or seatbelt and compatible child harness).

## Child Seat Suitability Guide

These child restraints, when used correctly, allow the driver to meet the Australian Road Rules in each state.

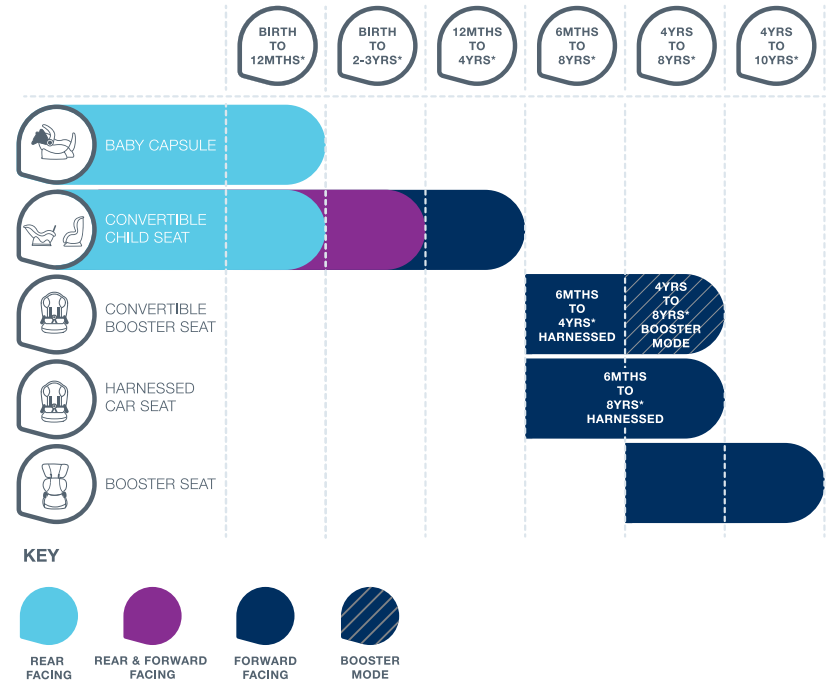

\* Ages are an approximation. Refer to the shoulder height markers for progression to forward facing mode or graduation to next restraint.

## Child Seat Features - Rearward Facing

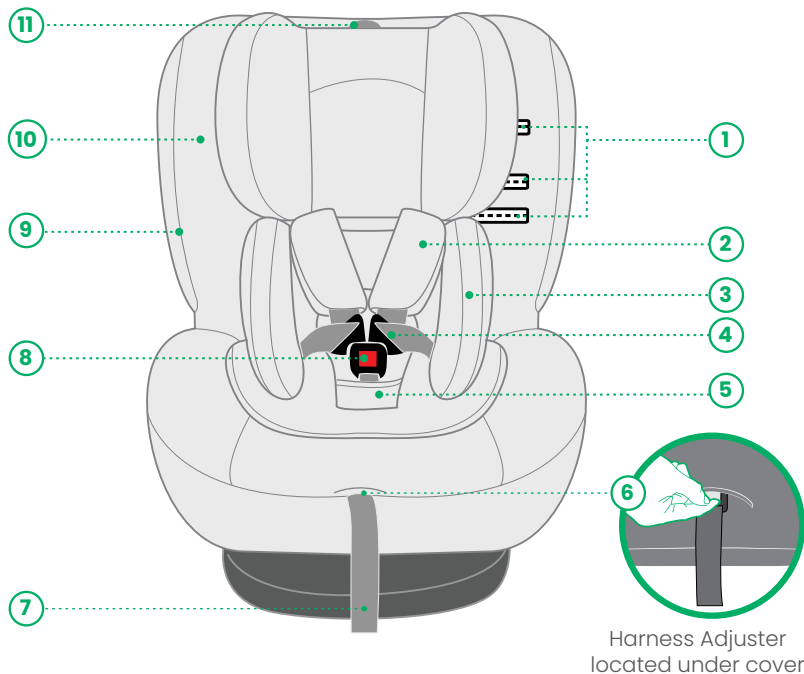

- |                                   |   |
|-----------------------------------|---|
| <b>1.</b> Shoulder Height Markers | <b>7.</b> Harness Adjuster Strap  |
| <b>2.</b> Shoulder Pads           | <b>8.</b> Release Buckle  |
| <b>3.</b> Infant Insert           | <b>9.</b> Buckle Tongue Holders (If supplied)<br>Or Magnets (If supplied) |
| <b>4.</b> Harness                 | <b>10.</b> Seat Cover   |
| <b>5.</b> Crotch Pad (If fitted)  | <b>11.</b> Headrest Adjuster  |
| <b>6.</b> Harness Adjuster        |   |

## Child Seat Features - Rearward Facing

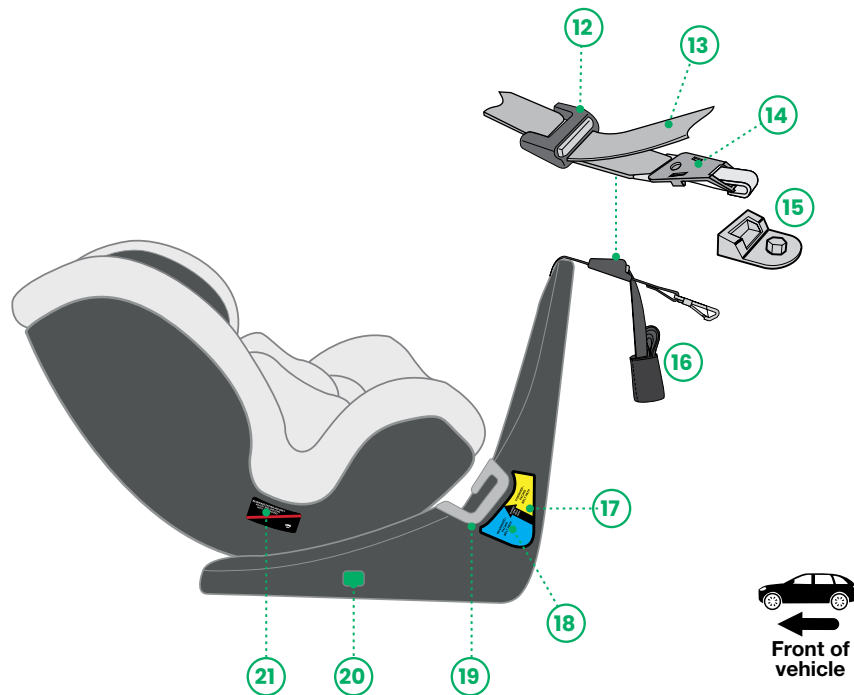

- |                                      |   |
|--------------------------------------|---|
| <b>12.</b> Top Tether Adjuster       | <b>17.</b> Forward-Facing Belt Path               |
| <b>13.</b> Top Tether Adjuster Strap | <b>18.</b> Rearward-Facing Belt Path              |
| <b>14.</b> Attachment Clip           | <b>19.</b> Seatbelt Hook                          |
| <b>15.</b> Vehicle Anchor Fitting    | <b>20.</b> Rotation Indicator (Green when locked) |
| <b>16.</b> Storage Pocket            | <b>21.</b> Rearward Facing Level Indicator        |



## Set up – General information for Rearward Facing

### Child seat upper anchorage point

This child seat must be installed using the top tether. The top tether will need to attach to the appropriate upper anchorage point for both rearward and forward facing modes. Refer to the car owner's handbook for anchorage locations or points. If your vehicle does not have an upper anchorage point then you will need to install an upper anchorage point. Refer to pages 78 to 82.

### Is there enough room?

#### ✓ Rearward Facing Measurements

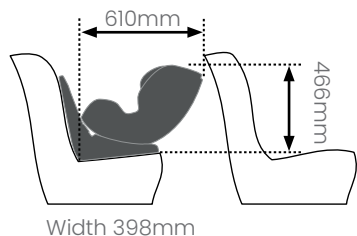

To ensure that the space is sufficient, the purchaser should check the measurements between the vehicle's rear and front seats in which the child restraint is intended to be used for both rear facing mode and forward facing mode.



Do not allow the front seat to alter the installed angle of the restraint.

### ⚠ WARNINGS

Do not use the restraint without the top tether strap correctly attached.  
Do not use on any vehicle seat which faces sideways or rearwards.  
A rear facing child restraint should not be used in the front seat if a passenger airbag is fitted and cannot be disabled.

## Set Up – Installing Into Your Vehicle For Rearward Facing

1.

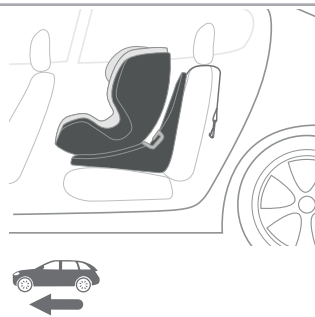

Place child seat in vehicle.  
Place Top tether over seat back

2.

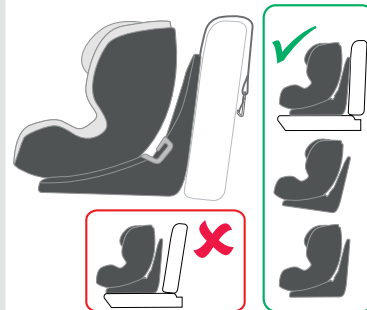

Ensure the child seat is firmly against the vehicle seatback – the rebound bar does not need to contact the vehicle seatback.

3.

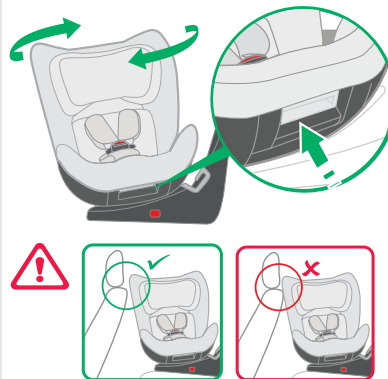

Lift the lever located under the seat front. Rotate the seat 90 degrees to face you, ensuring it can rotate freely without touching the seat in front.

## Set Up - Installing Into Your Vehicle For Rearward Facing

5.

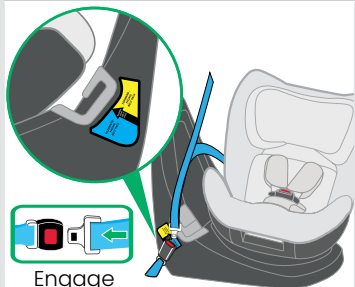

Engage  
Buckle  
Securely

Place both sash and lap belt  
between the rebound bar and  
engine buckle.

Follow the **FORWARD-  
FACING BELT PATH,**  
**REARWARD-FACING  
BELT PATH**

6.

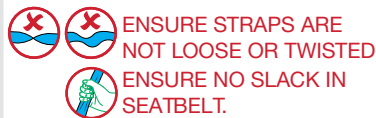
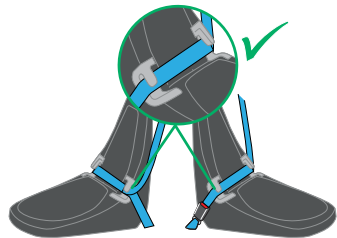

**ENSURE STRAPS ARE  
NOT LOOSE OR TWISTED**

**ENSURE NO SLACK IN  
SEATBELT.**

Ensure seatbelt is under the  
seatbelt hook.

Ensure there are no twists and  
remove unwanted slack on both  
sides.

7.

**SEATBELT MUST BE  
UNDER SEATBELT  
HOOKS**

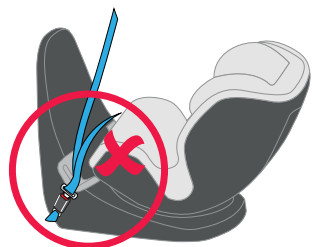

8.

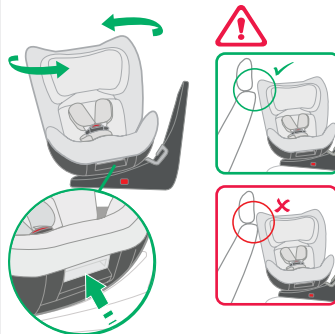

Lift lever from under seat and  
rotate seat to rearward facing  
position, ensuring it can rotate  
freely without touching the  
seat in front.

9.

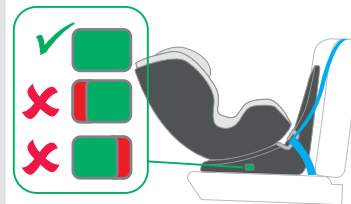

It will lock into position at  
each rotation  
Ensure window is entirely  
green once you have chosen  
your position.

10.

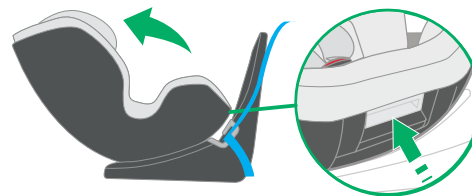

Lift the lever located  
under the seat front  
continue pulling the  
restraint forward until  
fully reclined into  
rearward facing.

## Set Up – Installing Into Your Vehicle For Rearward Facing

### Rearward Facing Level Indicator:

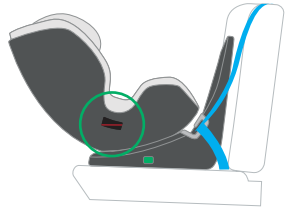

The Rearward Facing Level Indicator shows when your child seat is installed at the correct angle for your vehicle. It gives you confidence the child seat is positioned correctly whenever you travel.

To ensure correct installation, verify that the line on the level indicator is parallel to the road.

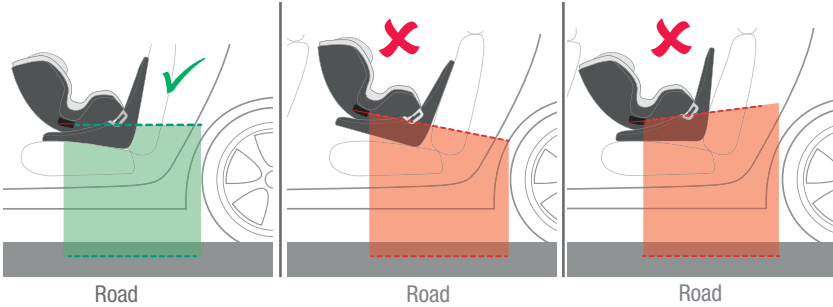

**!** **IMPORTANT:** This indicator should only be used in rearward facing mode.

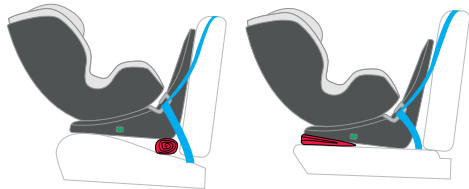

If the line is not parallel, please revisit steps 1-10 to confirm proper placement of the seat. You may need to adjust the seat by adding packing between the vehicle seat and the base, OR seek professional installation advice.

## Set Up – Installing Into Your Vehicle For Rearward Facing

11.

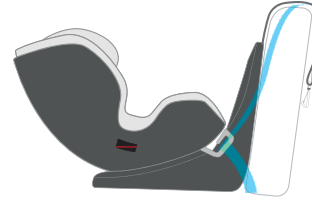

You have now successfully completed the seat belt installation and are now ready to install the top tether. See next page.

## Set Up - Top Tether For Rearward Facing

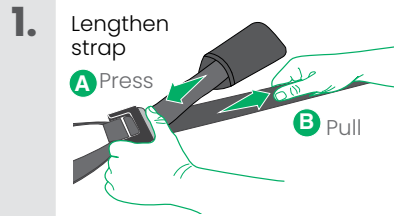

- A.** Press top tether adjuster button.
- B.** Lengthen top tether strap fully, ensure all unnecessary twists are removed.

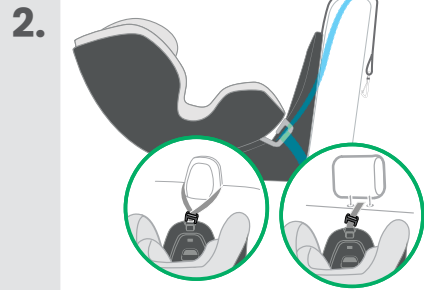

Place the top tether over the vehicle seatback, and if needed, remove the vehicle headrest. If you cannot remove the headrest, then ensure that the top tether straps are placed on the outer-sides of the headrest.

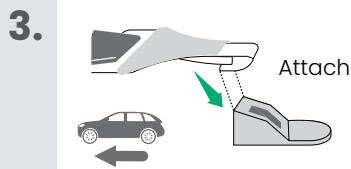

Connect top tether attachment clip to vehicle anchor fitting. Check your vehicle manual for the correct anchor fittings in your vehicle.

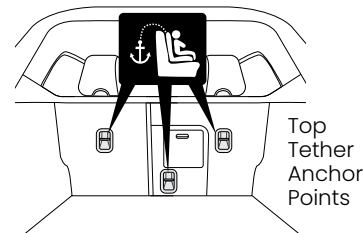

## Set Up - Top Tether For Rearward Facing

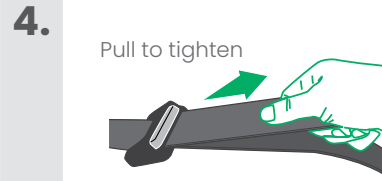

Ensure slack is removed from the top tether straps by pulling top tether adjuster strap. Do not over tighten as it may cause your child seat to lift.

- ALWAYS REMOVE SLACK IN THE TOP TETHER AND STORE STRAP.**
- ENSURE THE TOP TETHER STRAPS ARE NOT TWISTED.**

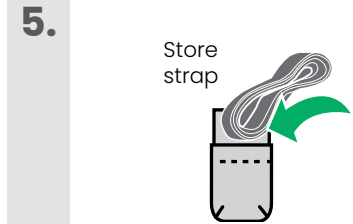

Roll up any excess strap and store in the pocket provided.

Ensure the storage pocket does not obstruct the seat rotation.



## Set Up – Top Tether For Rearward Facing

### CAUTION:

**CHILDREN CAN BE INJURED OR RESTRAINTS AND TOP TETHER STRAP DAMAGED BY UNSECURED CARGO IN A COLLISION. SECURE OR REMOVE HAZARDOUS CARGO BEFORE USING THIS CHILD RESTRAINT.**

### IMPORTANT:

The top tether strap must be fitted at all times.





Always secure the loose end of the top tether strap to prevent it hanging out of the car or being accessible by the child.

**ALWAYS ATTACH TOP TETHER HOOK AND REMOVE SLACK IN THE TOP TETHER STRAP.**

Take care to avoid contact with sharp objects which may damage the Top Tether webbing (e.g. Vehicle Headrest poles and pole guides). Remove vehicle headrest if necessary (Refer Vehicle Instruction Manual)

**Do not attach the top tether of two separate child restraints to the same vehicle anchorage.**

## Check list

-  check no seatbelt twists or loose
-  check rotation indicator
-  check level indicator
-  check top tether
-  check vehicle seatbelt is under seatbelt hooks

## Setup – Crotch Strap

### Crotch Strap Options

Average  
Newborn  
Crotch Strap

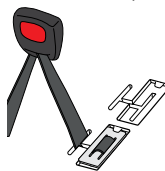

Smaller  
Newborn  
Crotch Strap

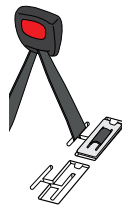

The child seat is fitted with two crotch strap positions for Rearward facing only. For smaller newborn and average newborn. Correct location of crotch strap will assist to securely position the infant and will help prevent infant from slipping further down the capsule or slumping.

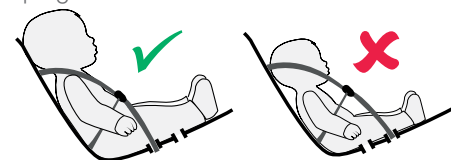

### Adjustment of Crotch Strap

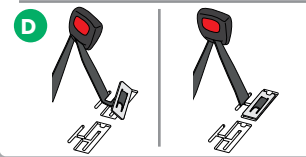
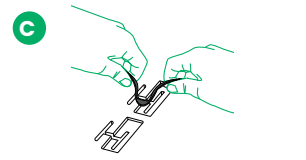
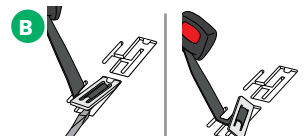

Lift seat cover away to expose the crotch strap slots.

- A. Decide which crotch strap position is preferable.
- B. Lift and slide out the metal 3-bar slide and rotate it through the slots until the crotch strap is free from the seat.
- C. Insert the crotch strap through the preferred slot by looping the strap back under the lip of the slot.
- D. Ensure the metal 3-bar slide is facing up. Push down to click into slot.
- E. Check both straps are equal length.

**Ensure crotch strap is not twisted and position the red buckle button outwards. Replace the crotch pad onto the crotch buckle and is in the correct slot in cover. See page 75.**

## Set Up - Headrest And Shoulder Harness For Rearward Facing



- A. Press top tether adjuster button.
- B. Lengthen top tether strap fully, ensure all unnecessary twists are removed.

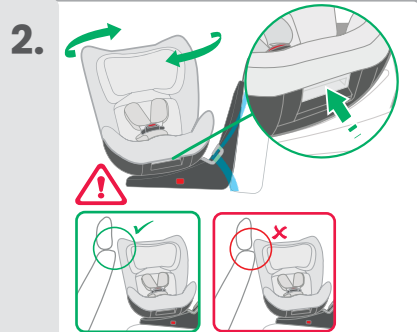

Lift the lever located under the front seat. Rotate the seat 90 degrees to face you, ensuring it can rotate freely without touching the seat in front.

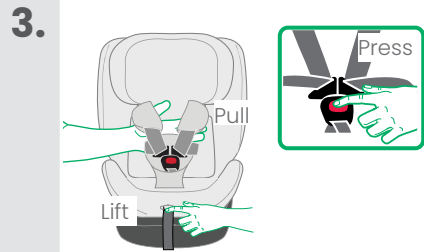

- A. Lift harness adjuster (located under trim.)
- B. Place your hand under both shoulder harness straps, then pull shoulder harness straps to lengthen.
- C. Disengage the buckle by pressing the red button.

## Set Up - Headrest And Shoulder Harness For Rearward Facing

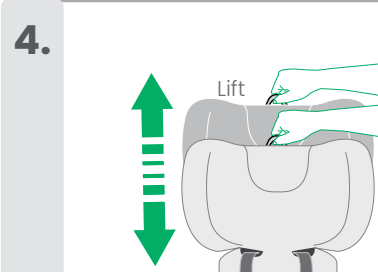

Lift lever to adjust headrest/harness slots.

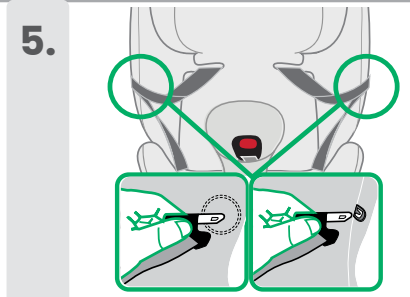

Place buckle tongues in/on holders (if supplied).

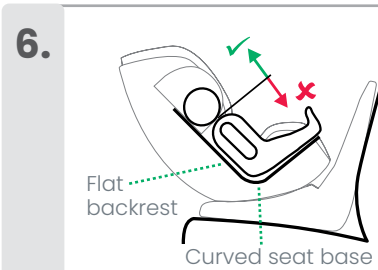

Place baby into the child seat. Ensure your baby is positioned with their back flat against the back rest and their bottom correctly positioned into the curved seat base.

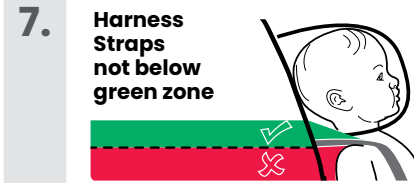

Check the headrest and shoulder slot position is level with the shoulders but not below. The shoulder straps must be in the slots which are nearest to the child's shoulders but not lower than the child's shoulders. **Always adjust the height of the shoulder straps as the child grows.**

## Set Up - Headrest And Shoulder Harness For Rearward Facing

8.

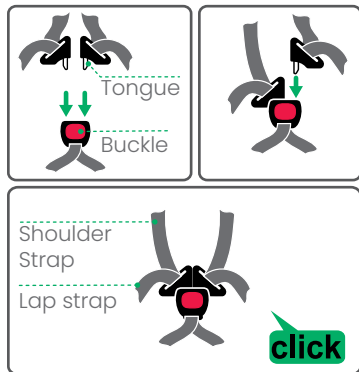

Engage Buckle.

**ENSURE BUCKLE IS ALWAYS CONNECTED DURING USE.**  
**ENSURE ALL HARNESS STRAPS ARE NOT TWISTED.**

9.

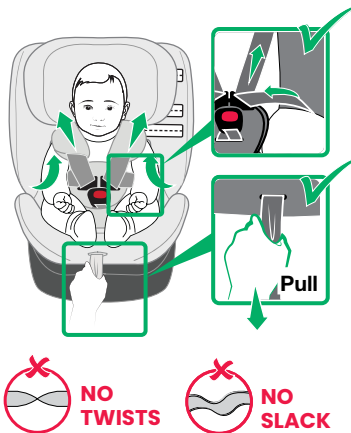

**A.** Remove all slack from the lap strap area (including behind baby's bottom), by pulling up on the shoulder straps.

**B.** Pull harness adjuster strap to tighten. Ensure a firm but comfortable fit.

**REMOVE ALL HARNESS SLACK**

Remove slack from the top tether straps by pulling the top tether adjuster strap.

## Set Up - Headrest And Shoulder Harness For Rearward Facing

10.

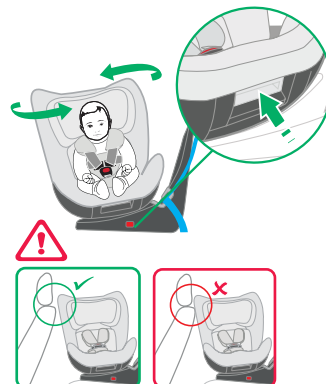

Lift lever from under seat and rotate seat to rearward facing position, ensuring it can rotate freely without touching the seat in front.

11.

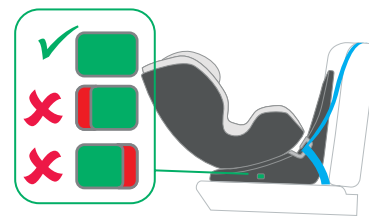

It will lock into position at each rotation. Ensure window is entirely green once you have chosen your position.

**Check blankets or any wraps are not in the way of the seat rotation.**

12.

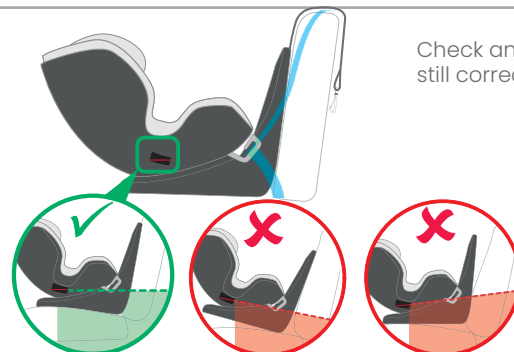

Check angle of child seat is still correct. (See page 33).

## Set Up – Headrest And Shoulder Harness For Rearward Facing

**! WARNING:**  
**DO NOT LEAVE CHILDREN UNATTENDED IN THE CAR.**

Do not harness an infant wrapped in a blanket or swaddled as this increases the risk of ejection and injury or death in a crash. The harness needs to fit firmly to the baby, any blanket or other covering may be placed over the harness after it is adjusted. Arms and legs must be free and not bound or wrapped together. The legs must sit on each side of the crotch strap.

### Check list

- ✓ check seat can rotate freely.
- ✓ check top tether.
- ✓ check shoulder height marker and child's shoulder
- ✓ check buckle is always connected during use.
- ✓ check all harness straps are not twisted.
- ✓ check rotation indicator.
- ✓ check level indicator.

## Remove Child From Child Seat For Rearward Facing

1.

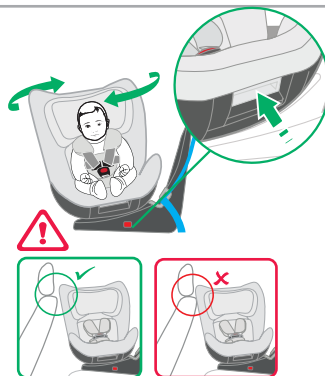

Lift the lever located under the seat front. Rotate the seat 90 degrees to face you, ensuring it can rotate freely without touching the seat in front.

2.

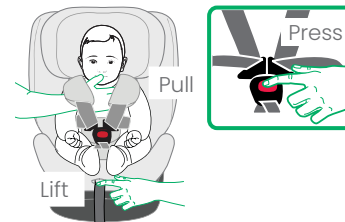

- A.** Lift harness adjuster (located under trim.)
- B.** Place your hand under both shoulder harness straps, then pull shoulder harness straps to lengthen.
- C.** Disengage the buckle by pressing the red button.

3.

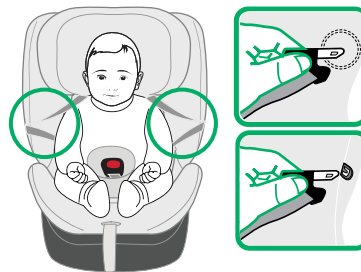

Place harness buckles in/on holder (if supplied).  
Lift child from the child seat.

## Remove Child Seat From Vehicle For Rearward Facing



- A.** Press top tether adjuster button.
- B.** Lengthen top tether strap fully.

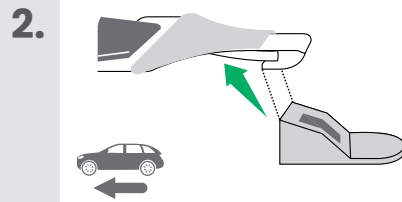

Disconnect top tether attachment clip from vehicle anchorage fitting

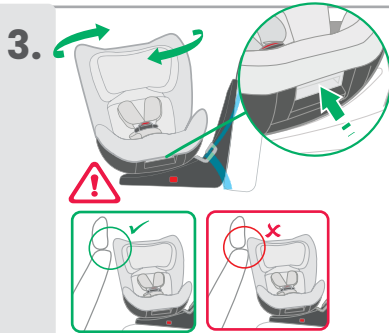

Lift the lever located under the seat front. Rotate the seat 90 degrees to face you, ensuring it can rotate freely without touching the seat in front.

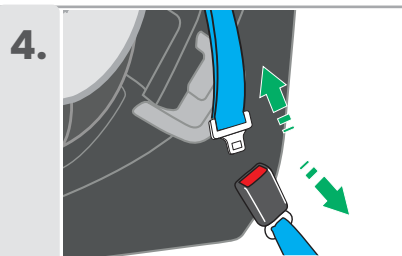

Disengage the vehicle seatbelt buckle.

## Remove Child Seat From Vehicle For Rearward Facing

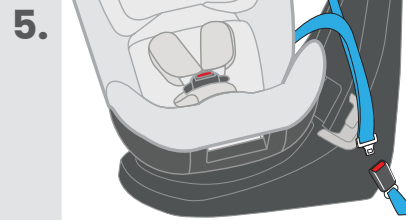

Unthread the vehicle seatbelt and allow the seatbelt to feed back into the retractor.  
Remove Child seat from vehicle.

## Child Seat Features - Forward Facing

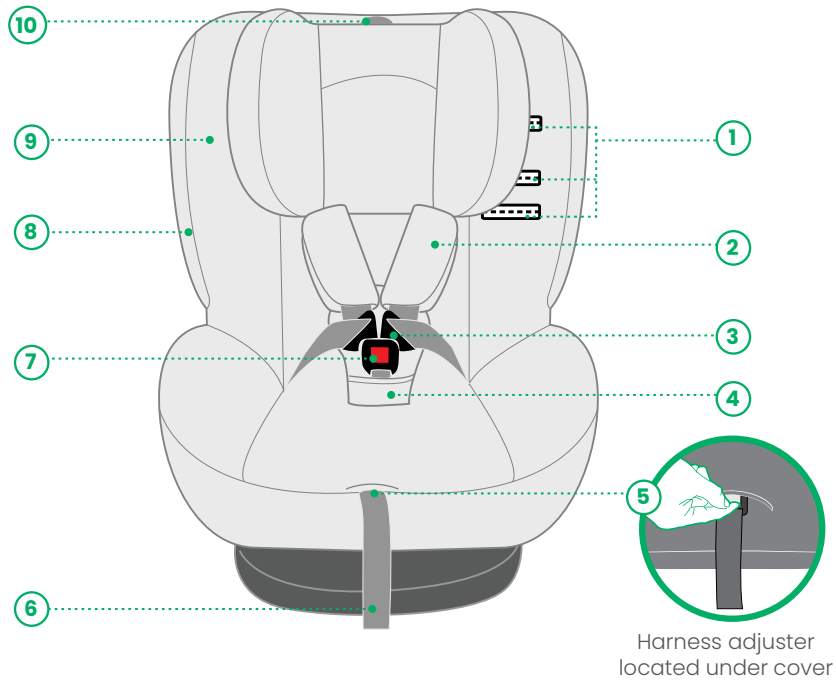

- |                            |  |
|----------------------------|--|
| 1. Shoulder Height Markers | 7. Release Buckle  |
| 2. Shoulder Pads           | 8. Buckle Tongue Holders (If supplied)<br>Or Magnets (If supplied) |
| 3. Harness                 | 9. Seat Cover  |
| 4. Crotch Pad (If fitted)  | 10. Headrest Adjuster  |
| 5. Harness Adjuster        |  |
| 6. Harness Adjuster Strap  |  |

## Child Seat Features - Forward Facing

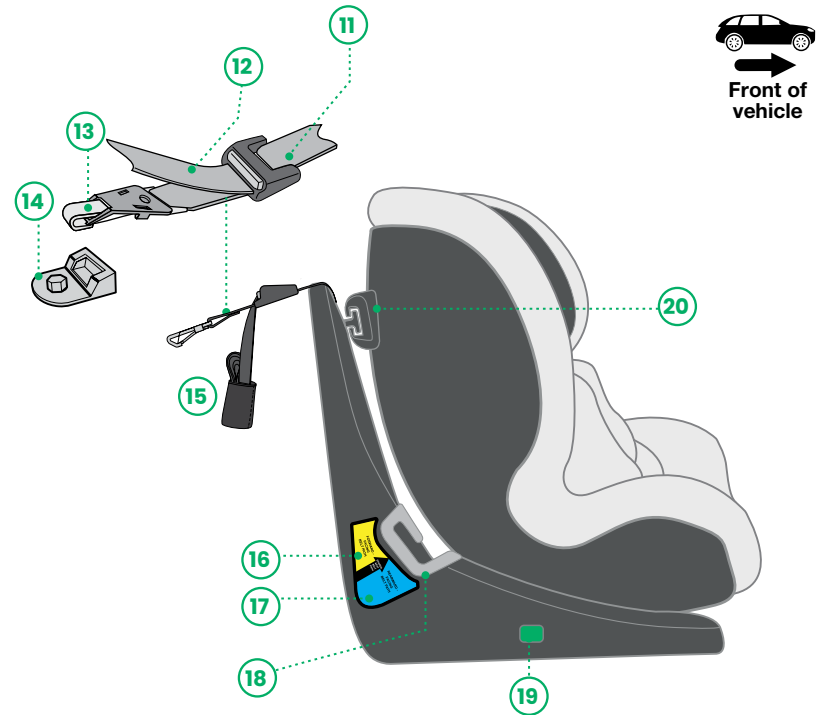

- |                               |   |
|-------------------------------|---|
| 11. Top Tether Adjuster       | 16. Forward-Facing Belt Path                  |
| 12. Top Tether Adjuster Strap | 17. Rearward-Facing Belt Path                 |
| 13. Attachment Clip           | 18. Belt Hook                                 |
| 14. Vehicle Anchor Fitting    | 19. Rotation Indicator<br>(Green when locked) |
| 15. Storage Pocket            | 20. Forward Facing Seat Lock                  |

## Setup - General Information For Forward Facing

### Is there enough room?

#### Forward Facing Measurements

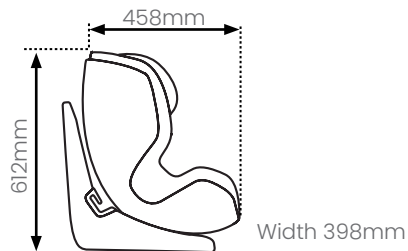

To ensure that the space is sufficient, the purchaser should check the measurements between the vehicle's rear and front seats in which the child restraint is intended to be used for forward facing mode.

### **⚠ WARNINGS**

Do not use the restraint without the top tether strap correctly attached. If an airbag is fitted in the desired seating position where the child restraint is fitted, follow the vehicle manufacturer's warnings and instructions.

## Set Up - Installing Into Your Vehicle For Forward Facing

### 1. Remove infant insert

**Transition From Rearward Facing To Forward Facing Mode:** Remove infant insert. Shoulder pads and crotch pad may continue to be used if required.

### 2.



Place child seat in vehicle.  
Place Top tether over seat back

### 3.

Ensure the child seat is firmly against the vehicle seatback—the rebound bar does not need to have complete contact the vehicle seatback, if desired this gap may be packed

### 4.

Lift the lever located under the seat front. Rotate the seat 90 degrees to face you, ensuring it can rotate freely without touching the seat in front.

## Set Up - Installing Into Your Vehicle For Forward Facing

5.

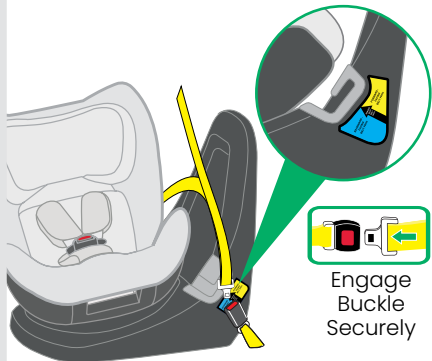

Engage  
Buckle  
Securely

Place both sash and lap belt between the rebound bar and belt hooks and engage buckle.

Follow the **FORWARD-FACING BELT PATH, REARWARD-FACING BELT PATH**

7.

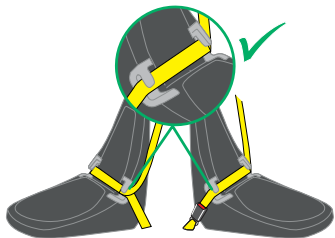

**ENSURE STRAPS ARE NOT LOOSE OR TWISTED**

**ENSURE NO SLACK IN SEATBELT**

Ensure seatbelt is under the seatbelt hooks.  
Ensure there are no twists and remove unwanted slack on both sides.

8.

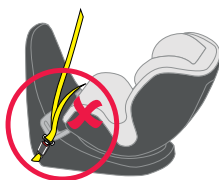

**SEATBELT MUST BE UNDER SEATBELT HOOKS**

9.

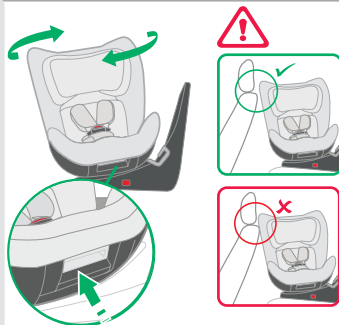

Lift the lever located under the seat front. Rotate the seat 90 degrees, ensuring it can rotate freely without touching the seat in front.

10.

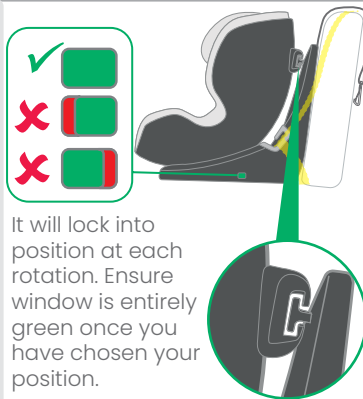

It will lock into position at each rotation. Ensure window is entirely green once you have chosen your position.

Ensure the Forward Facing Seat Lock is engaged when the seat is rotated fully to the forward position.

11.



You have now successfully completed the seat belt installation and are now ready to install the top tether. See next page.

## Set Up – Top Tether For Forward Facing



- A.** Press top tether adjuster button.
- B.** Lengthen top tether strap fully, ensure all unnecessary twists are removed.



Place the top tether over the vehicle seatback, and if needed, remove the vehicle headrest. If you cannot remove the headrest, then ensure that the top tether straps are placed on the outer-sides of the headrest.

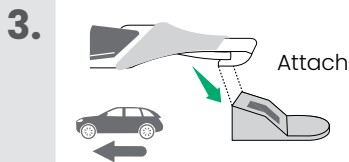

Connect top tether attachment clip to vehicle anchor fitting. Check your vehicle manual for the correct anchor fittings in your vehicle.

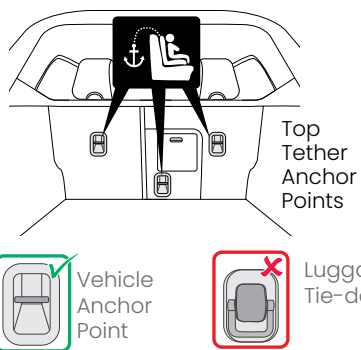

## Set Up – Top Tether For Forward Facing

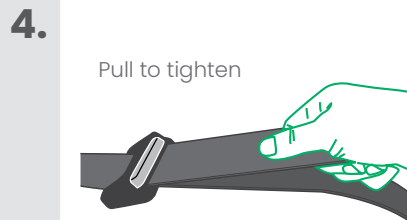

Ensure slack is removed from the top tether straps by pulling top tether adjuster strap. Do not over tighten as it may cause your child seat to lift.

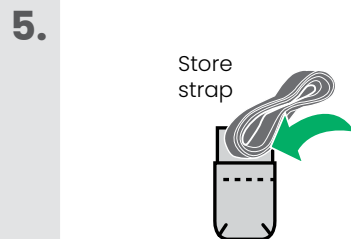

Roll up any excess strap and store in the pocket provided.

Ensure the storage pocket does not obstruct the seat rotation.

## Set Up – Top Tether For Forward Facing

**⚠ CAUTION:**  
**CHILDREN CAN BE INJURED OR RESTRAINTS AND TOP TETHER STRAP DAMAGED BY UNSECURED CARGO IN A COLLISION. SECURE OR REMOVE HAZARDOUS CARGO BEFORE USING THIS CHILD RESTRAINT.**

**⚠ IMPORTANT:**

The top tether strap must be fitted at all times.  
Always secure the loose end of the top tether strap to prevent it hanging out of the car or being accessible by the child.

**ALWAYS ATTACH TOP TETHER HOOK AND REMOVE SLACK IN THE TOP TETHER STRAP.**

Take care to avoid contact with sharp objects which may damage the Top Tether webbing (e.g. Vehicle Headrest poles and pole guides). Remove vehicle headrest if necessary (Refer Vehicle Instruction Manual)

**Do not attach the top tether of two separate child restraints to the same vehicle anchorage.**

## Check list

- ✓ check no seatbelt twists or loose
- ✓ check rotation indicator
- ✓ check top tether loop is stored away
- ✓ check vehicle seatbelt is under seatbelt hooks

## Set Up – Headrest And Shoulder Harness For Forward Facing

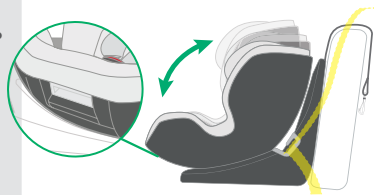
**1.** 

When you convert your child seat to forward facing mode, there are three, simple to use forward facing recline positions you can choose from to ensure your child travels as comfortably as possible. Lift lever from under seat front to convert.

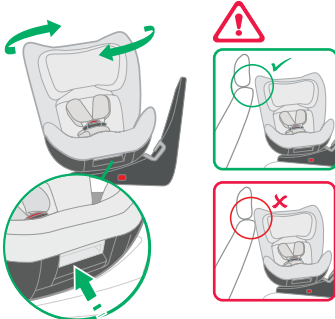
**2.** 

Lift the lever located under the seat front. Rotate the seat 90 degrees to face you, ensuring it can rotate freely without touching the seat in front.

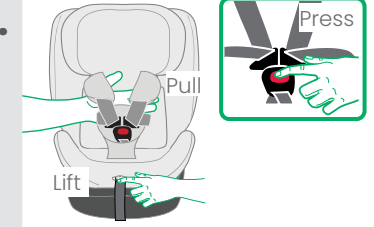
**3.** 

**A.** Lift harness adjuster (located under trim.)  
**B.** Place your hand under both shoulder harness straps, pull shoulder harness straps to lengthen.  
**C.** Disengage the buckle by pressing the red button.

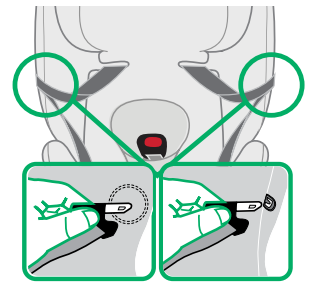
**4.** 

Place buckle tongues in/on holders (if supplied).

## Set Up – Headrest And Shoulder Harness For Forward Facing

5.

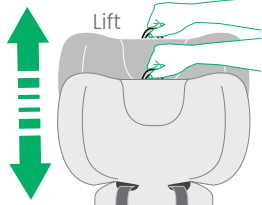

Lift lever to adjust headrest/harness slots.

6.



The shoulder straps must be in the slots which are nearest to the child's shoulders, but not more than 25mm below the child's shoulder.

**Always adjust the height of the shoulder straps as the child grows.**

7.

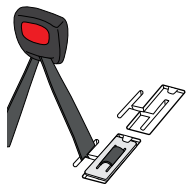

Check crotch strap is in the correct location in forward facing mode see page 42 to adjust to the correct slot.

## Set Up – Headrest And Shoulder Harness For Forward Facing

8.

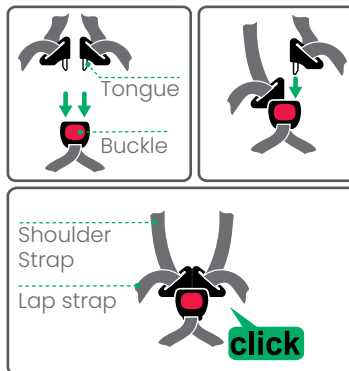

Engage Buckle.

**ENSURE BUCKLE IS ALWAYS CONNECTED DURING USE.  
ENSURE ALL HARNESS STRAPS ARE NOT TWISTED.**

9.

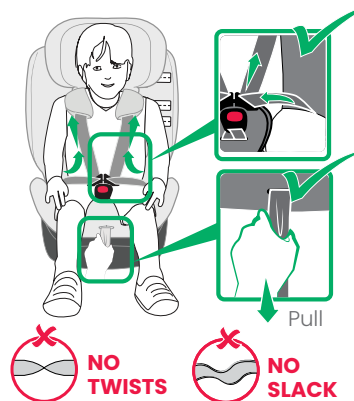

**A.** Remove all slack from the lap strap area (including behind baby's bottom), by pulling up on the shoulder straps.

**B.** Pull harness adjuster strap to tighten. Ensure a firm but comfortable fit.

**REMOVE ALL HARNESS SLACK**

Remove slack from the top tether straps by pulling the top tether adjuster strap.



**WARNING:  
DO NOT LEAVE CHILDREN UNATTENDED IN THE CAR.**

## Set Up - Headrest And Shoulder Harness For Forward Facing

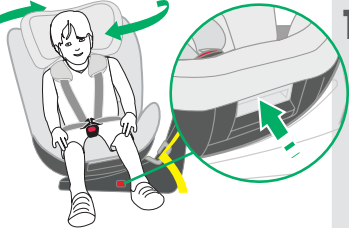
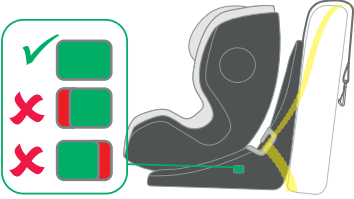
**10.**  **11.** 

Lift lever from under seat and rotate seat to forward facing position

It will lock into position at each rotation  
Ensure window is entirely green once you have chosen your position.

### Check list

- ✓ check seat can rotate freely
- ✓ check rotation indicator
- ✓ check shoulder height marker and child's shoulder
- ✓ check buckle is always connected during use
- ✓ check crotch buckle is in correct slot
- ✓ check all harness straps are not twisted

## Remove Child From Child Seat For Forward Facing

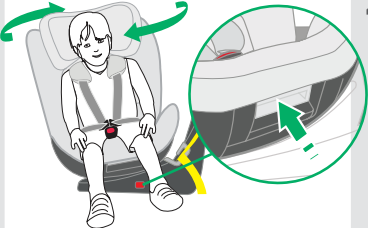
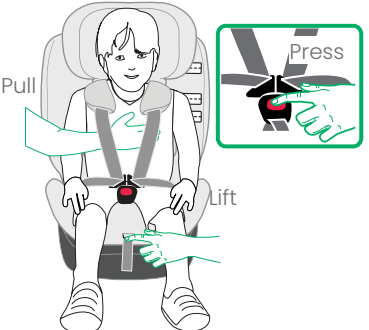
**1.**  **2.** 

Lift the lever located under the seat front. Rotate the seat 90 degrees to face you.

**A.** Lift harness adjuster (located under trim.)  
**B.** Place your hand under both shoulder harness straps, then pull shoulder harness straps to lengthen.  
**C.** Disengage the buckle by pressing the red button.

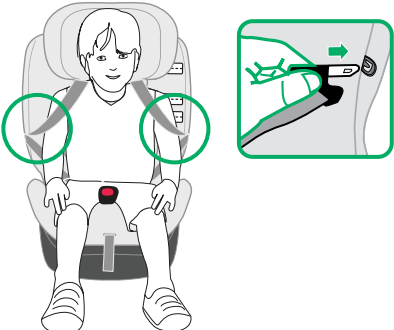
**3.** 

Place harness buckles in buckle tongue or magnet holder. Remove child from the child seat.

## Remove Child Seat From Vehicle For Forward Facing

### 1. Lengthen strap

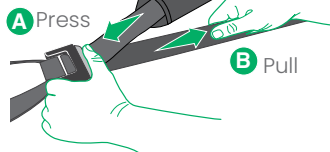

- A.** Press top tether adjuster button.
- B.** Lengthen top tether strap fully.

### 2.

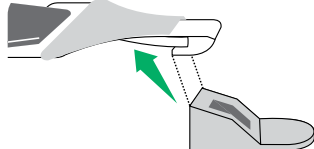

Disconnect top tether attachment clip from vehicle anchorage fitting

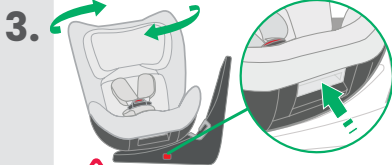

Lift the lever located under the seat front. Rotate the seat 90 degrees to face you, ensuring it can rotate freely without touching the seat in front.

### 4.

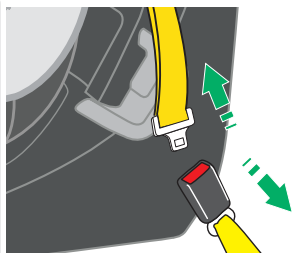

Disengage the vehicle seatbelt buckle.

## Remove Child Seat From Vehicle For Forward Facing

### 5.

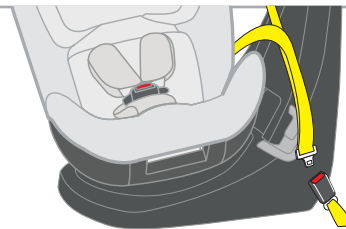

Unthread the vehicle seatbelt and allow the seatbelt to feed back into the retractor. Remove Child seat from vehicle.

## Care And Maintenance

### Regular Care Of This Restraint:

Please check the following items regularly to ensure the safety of your child.

- A. Check the condition of the harness straps, i.e. No damage or fraying.
- B. Check the condition of the seat structure, i.e. No cracks or other forms of damage.
- C. Check the harness adjuster is operating correctly.
- D. Ensure the buckle is free of fluff, liquid or other matter that may enter the buckle opening. Clean the buckle if it is difficult to engage. See next page. Immediate repair is required if any of the above issues are observed. Contact Britax® Customer Service 1300 303 330.
- E. Regularly check the restraint components, straps and other fitments for correct function and condition. If faulty, cease using and seek repair by Britax®.
- F. Protect all webbing from abrasion and cutting by sharp corners and edges.
- G. Regularly vacuum under the seat cover to remove accumulated food etc. Pay particular attention to Lower Adjuster area as food ingress can allow webbing to slip.

### Cleaning Child Seat

**HARDWARE:** Use only mild soap to clean all metal and plastic parts of your child's restraint, using a damp sponge or cloth. Do not use chemicals or cleaning agents. Do not try to place any hardware into a washing machine.

**STRAPS/HARNES:** We recommend spot cleaning straps and harness with a damp sponge or cloth using only cold or warm water. Never place any straps or harness into a washing machine or tumble dryer.

### Washing Care For Cover

- Gentle cold machine wash
- Do not bleach, soak or wring
- Do not tumble dry
- Do not dryclean
- Dry flat in shade
- Do not iron

## Care And Maintenance

### Buckle Operation

To ensure the buckle remains operational, the inside of the buckle must be kept free of liquids, sand, dirt, fluff, food or similar substances. If the buckle is not operating or you do not hear a strong audible click when the second tongue is inserted then the buckle needs to be washed or replaced. The buckle is fully engaged when both tongues are inserted and a 'click' is heard. Contact Customer Service for assistance.

### Clean Harness Buckle:

If sticky liquids such as baby formula, fruit juice, etc. get inside your harness buckle, it may become sluggish. An indication of a sluggish harness buckle is that you cannot hear a click when engaging the second harness tongue. To restore the harness buckle to good working order it needs to be cleaned as follows:

1.

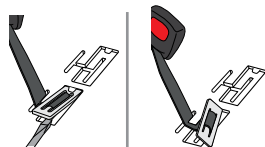

Lift seat cover away to expose the crotch strap slots.

To remove the crotch strap buckle for cleaning, lift and slide out the metal 3-bar slide and rotate it through the slots until the crotch straps is free from the seat.

2.

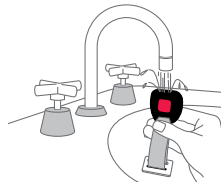

Place the harness buckle under warm (max. 40 degrees celsius) running water as shown below. Let the water run through the mouth of the buckle for five minutes. Check the harness buckle is clean by engaging the harness tongues and buckle several times until you hear a click.

## Care And Maintenance

3.

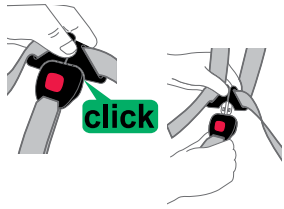

If you still cannot hear a strong audible click then repeat the cleaning process several times.

Refit the harness buckle to the restraint ensuring the red button facing outwards and the 3-bar slide is fed through the same slots.

If the harness buckle cannot be returned to its original working condition then contact Britax® Customer Service for assistance.

4.

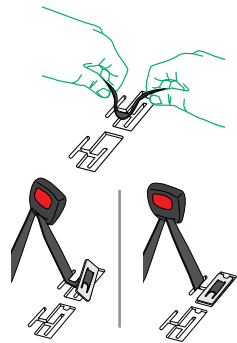

To replace, Insert the crotch strap through the preferred slot by looping the strap back under the lip of the slot.

Ensure the metal 3-bar slide is facing up. Push down to click into slot.

Check both straps are equal length.

**Ensure crotch strap is not twisted and positions the red buckle button outwards.**

See page 42 for more details.

## Care And Maintenance - Remove Cover

1.



NOTE: There is no need to disconnect the shoulder harness assembly straps from restraint. Remove the restraint from vehicle. Disengage the harness tongues from the harness buckle.

Remove any accessories, inserts, crotch pad and shoulder pads (if supplied).

2.

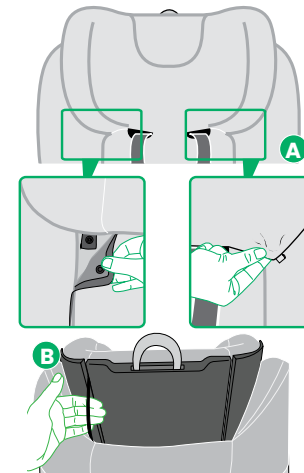

**To Remove Headrest Cover:**

**A.** Lift headrest to the highest position and unclip press studs on both sides, then unhook clips on both sides attached under headrest wings.

**B.** Behind the headrest reveal the hidden elastic, lift out and remove elastic over and away from headrest.

Peel headrest cover away.

## Care And Maintenance – Remove Cover

3.

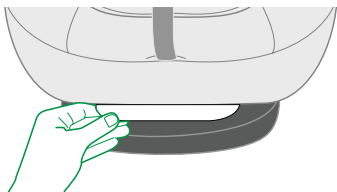

### To Remove Cover:

Remove the plastic tab located underneath the front of the seat.

4.

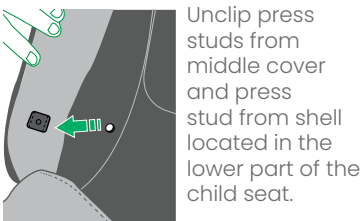
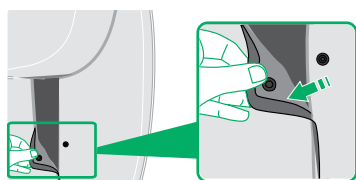

Unclip press studs from middle cover and press stud from shell located in the lower part of the child seat.

5.

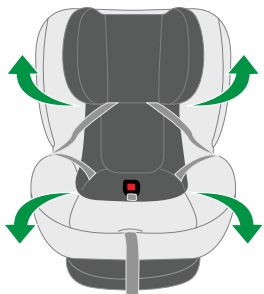
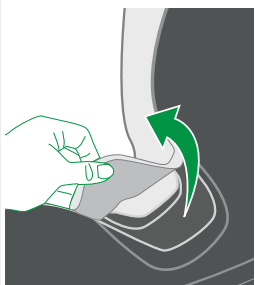

Remove the cover from around the frame seat. Pull the adjuster strap through the cover. Lift up and away from seat.

## Care And Maintenance – Replace Cover

1.

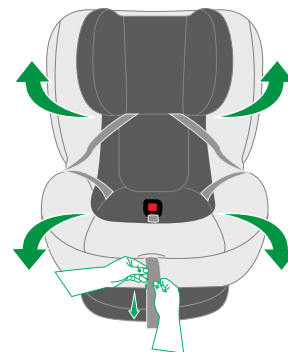
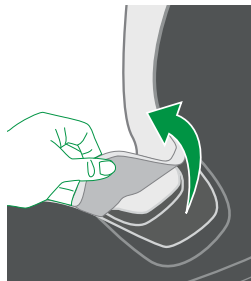

**To Replace Cover:**  
Stretch the cover over the headrest and around the seat, tucking it in securely all the way around. Pull the adjuster strap through.

2.

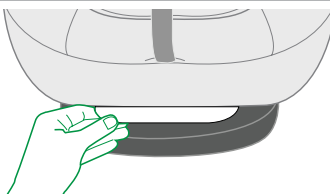

Flip the plastic tab underneath the front of the seat.

3.

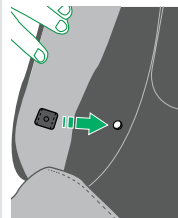
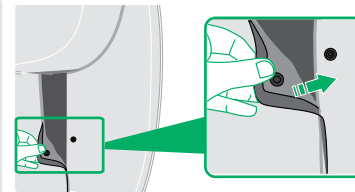

Attach the press studs from middle cover and attach the press stud to the shell located in the lower part of the child seat.

## Care And Maintenance – Replace Cover

4.

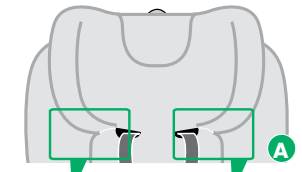

**To Replace Headrest Cover:**

- A.** Adjust the headrest to its highest position. Secure the clips beneath and beside the headrest wings.

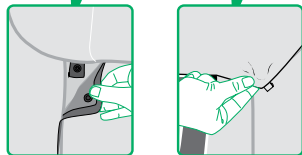

- B.** Stretch headrest cover over headrest. Replace elastic behind headrest into the recess.



- C.** Ensure the shoulder harness straps are in the slots, then attach the press studs to secure the shoulder harness in place.

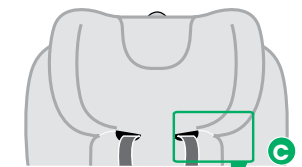

Replace any accessories, infant insert, crotch pad and shoulder pads (if supplied).

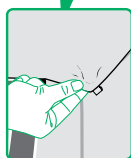

## Care And Maintenance – Replace Cover

**ONLY USE BRITAX® SEAT COVERS AND ACCESSORIES THAT ARE DESIGNED AND TESTED FOR USE WITH THIS PRODUCT.**



**VERY IMPORTANT:**

**Only replace the cover with Britax® supplied replacement cover with identical shoulder height markers or a replacement cover meeting AS/NZS 8005.**

## Accessories

The following instructions apply to accessories that may be supplied with this restraint at point of purchase. The accessories are for comfort use only. Use of aftermarket accessories, which are accessories not provided with this child restraint, can reduce the safety provided by the child restraint and may cause injury or death. Always follow the instructions covering the use of accessories provided with this child seat and the instructions provided with the accessory. If an aftermarket accessory is used that is not recommended by Britax®, ensure that the accessory is compliant with AS/NZS 8005 and is stated as suitable for use with this specific child restraint.

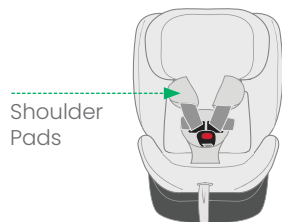

### Shoulder Pads (If Supplied)

Shoulder Pads give extra comfort for your child when using the harness. They're easy to remove and it makes washing them a breeze - unclip the studs to clean them and fit them back onto the shoulder harness straps once done.

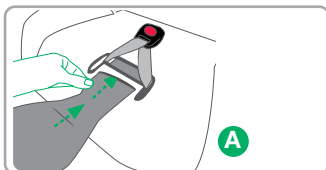

A

### Crotch Pad (If Supplied)

The crotch pad makes it easier to place your child in and out of the child seat. It prevents your child from sitting on the buckle when seated in both rearward and forward facing modes.

#### To remove

Feed the crotch buckle through the crotch pad slot. Remove crotch pad.

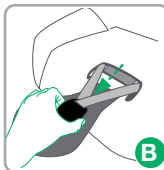

B

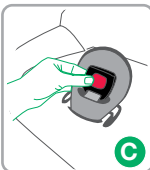

C

#### To replace

Feed crotch pad through base cover front slot. Feed crotch buckle through crotch pad slot. Ensure the crotch pad is behind the buckle. See illustration C.

## Accessories

### Inserts (If Supplied)

For use until infant reaches the lower height marker (approx 18mth old)

Designed to provide additional support for smaller babies. Discontinue use at the lower height marker or when the insert is a tight fit or creates discomfort for larger babies.

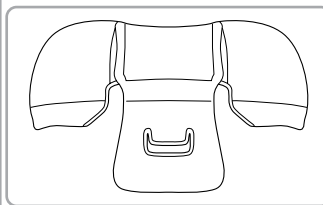

#### The Comfort Insert

Designed to support smaller babies. Discontinue use at the lower height marker or when the insert is a tight fit or creates discomfort for larger babies.

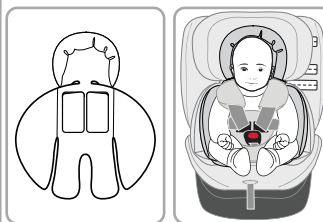

#### Newborn Insert

Designed to offer maximum support for smaller babies. The Newborn Insert can be used 'stacked' on top of either the Infant Insert or the Flexi Infant Comfort Insert or it can be used on its own. Discontinue use at the lower height marker or when your baby no longer requires the additional support.

#### To replace infant insert

- Disconnect the buckle and place the insert under the shoulder and lap straps.
- Feed the crotch strap through the insert and re-connect buckle.
- If using the Flexi Infant Comfort Insert, re-attached side wings if required.

## Accessories

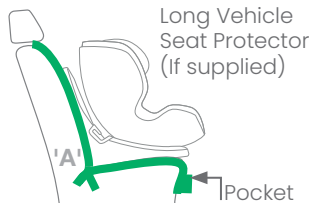

Long Vehicle Seat Protector (If supplied)

### Vehicle Seat Protector (If Supplied)

The Vehicle Seat Protector has been specifically designed to protect your vehicle seat when using your child seat.

Place pocket on edge of seat, smooth back toward seat joint ('A') and fit in any excess Vehicle Seat Protector into the join of the vehicle seat ('A').

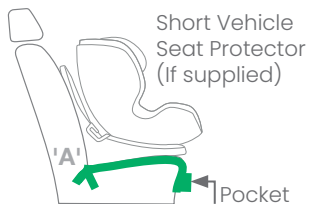

Short Vehicle Seat Protector (If supplied)



### CAUTION:

The Vehicle Seat Protector pocket is designed for small, light items. To avoid damage do not overload the pocket.

Note: Some Vehicle Seat Protector may not have pockets.

## Installation Of Vehicle Upper Anchor Point

Consult the vehicle owner's handbook for location of anchorage fittings or anchorage points and the possible use of spacers. Some vehicles may have an anchor fitting fitted by the vehicle manufacturer. If anchorage points cannot be found refer to car manufacturer or local child restraint fitting station or traffic authority for optimum position of upper anchorage point and the use of spacers.

### TOP TETHER STRAP



### IMPORTANT:

THE ATTACHMENT CLIP COVER MUST ALWAYS BE USED AS IT PREVENTS THE RISK OF INCORRECT FITMENT OF THE ATTACHMENT CLIP TO THE UPPER ANCHORAGE POINT. BEFORE EACH USE OF THE RESTRAINT ALWAYS ENSURE THAT THE ATTACHMENT CLIP IS CORRECTLY ENGAGED TO THE UPPER ANCHORAGE POINT AND NOT HOOKED TO OR FITTED TO, ANY OTHER OBJECT. THIS IS ESPECIALLY IMPORTANT IN VEHICLES SUCH AS STATION WAGONS, VANS, HATCH BACKS OR VEHICLES WITHOUT A FIXED PARCEL SHELF, SINCE THE ANCHOR POINT IS USUALLY NOT VISIBLE.

### IMPORTANT INSTALLATION NOTE:

In some vehicles the upper anchorage point in the rear vertical panel can only be installed in one way. Please refer to vehicle owner's handbook or a child restraint fitting station for correct method.

## Installation Of Vehicle Upper Anchor Point

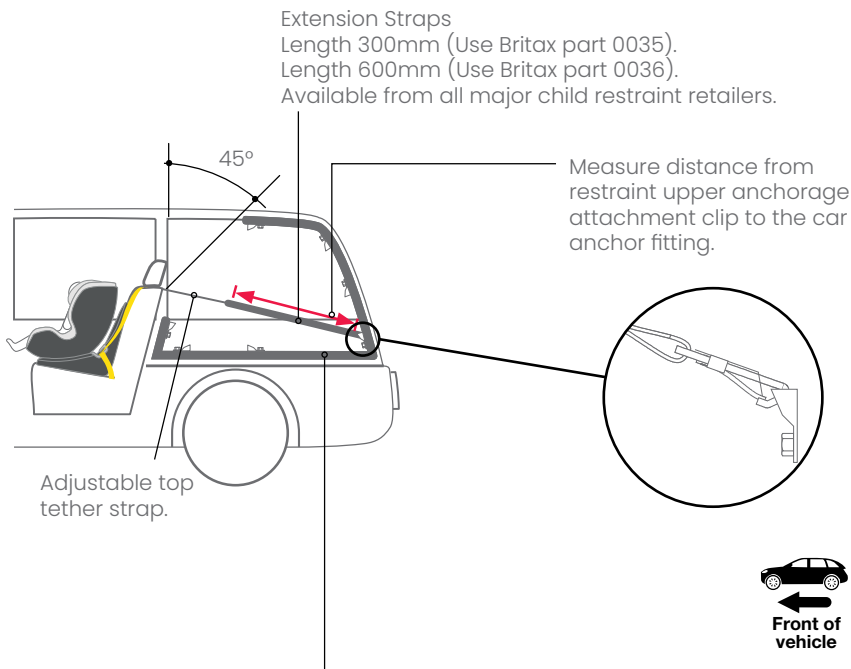

The shaded areas of this diagram illustrate the possible locations of the upper anchorage point (car anchor fitting). Within each shaded area is an upper anchorage point showing the correct way to install the fitting. Ensure the upper anchorage point is aligned as illustrated unless stated otherwise in the vehicle owner's handbook.

## Installation Of Vehicle Upper Anchor Point

### Upper Anchorage Fitting

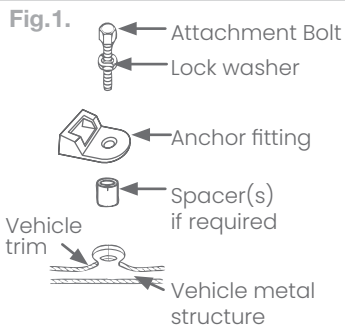

**IF THE CAR IS FITTED WITH A CHILD RESTRAINT UPPER ANCHORAGE POINT**  
 Locate the upper anchorage point behind the rear seating position (Consult the car owners handbook for the location of the upper anchorage point). The upper anchorage point should be directly behind and central to the restraint. Remove thread plug from the parcel shelf/floor/roof, etc. and install attachment bolt and fitting as shown in Fig 1.



**CAUTION: DO NOT OVERTIGHTEN ATTACHMENT BOLT.**  
 OVERTIGHTENING MAY FRACTURE OR BREAK BOLT. MAXIMUM TORQUE IS 20 Nm(14.75 ft.lb.)

Note: Minimum of five full turns of attachment bolt is required before tightening force is applied.

### Upper Anchorage Fittings For Sedans Only

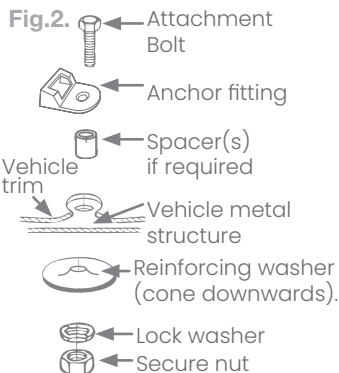

**IF THE CAR IS NOT FITTED WITH A CHILD RESTRAINT UPPER ANCHORAGE POINT**  
**For Sedans only** - Drill 9mm diameter hole in the parcel shelf on the centre line of the seating position as shown in Fig 3. Before drilling the hole, check the underside for accessibility. Install the attachment bolt as shown in Fig 2. It is recommended that this installation be carried out by a child restraint fitting station or licenced motor mechanic.

## Installation Of Vehicle Upper Anchor Point

**For vehicles other than Sedans** - In Australia, consult your nearest child restraint fitting station or traffic authority for vehicle inspection to find the best, correct position for the placement of the upper anchorage point, and for the correct attachment bolt length and use of spacers. In New Zealand, consult the agent for the vehicle. Note to Queensland purchasers: The installation of anchorage points must be approved by authorised officers appointed by Queensland Transport. Authorised officers can be sourced from all Queensland Transport Customer Service and Queensland Ambulance Service Centres.



NOTE: Marking on the top of a Grade 5 Bolt. Do not use any bolt without these marks.

ONLY USE A 5/16 UNC GRADE 5 BOLT. IF THE BOLT IS NOT THE CORRECT LENGTH THE CAR MANUFACTURER'S HAND BOOK CAN PROVIDE ADVICE ON THE CORRECT LENGTH BOLT.

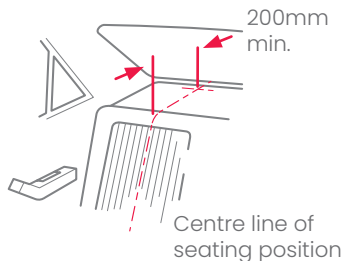

Fig.3.



CHILD RESTRAINTS MUST NOT BE ATTACHED TO UNSOUND METAL OR TO WOOD, OR SYNTHETIC STRUCTURES. WHEN DRILLING 9 MM HOLE DO NOT DRILL THROUGH FUEL LINES, FUEL TANKS, ELECTRICAL WIRING, OR RADIO SPEAKERS. WEBBING STRAPS MUST BE PROTECTED FROM SHARP CORNERS AND EDGES. THE ANCHOR FITTING MUST BE USED ONLY AS DESCRIBED ABOVE. IT MUST NOT BE HOOKED ONTO ANY OTHER OBJECT.

## Installation Of Vehicle Upper Anchor Point

**Car Installation Accessories** (From retailers of Britax products)

Extra Anchor Kits: Available for using the restraint in additional cars.

Re-order no: 0038

Extension Straps: May be required for cars without a fixed parcel shelf.

Re-order no: 0035 (Length 300mm) or  
0036 (Length 600mm)

## In Case Of Accident

### Crash Exchange

We would never want you to experience an accident, but unfortunately accidents do happen.

If you experience an accident you may be eligible for a free replacement.

The Britax Safe-n-Sound® Crash Exchange Program is a voluntary program designed to ensure our children are safe and that any seat that may have experienced a severe crash is taken out of the market.

There is no method of determining if the restraint has been damaged in a severe crash, so the restraint should be destroyed as the crash may reduce the child restraint's ability to perform.

Since its inception in 2006, the Crash Exchange program has helped hundreds of families ensure their children have new restraints and that the restraints are not sold second hand placing others at risk.

If your restraint has been involved in a severe crash, you should destroy the restraint even if no damage is obvious. Restraints are eligible for exchange if they have been involved in a severe crash in Australia or New Zealand and meet all stated criteria. (A severe crash is considered as being one where the main body structure of the vehicle is distorted).

The Britax Safe-n-Sound® child safety restraints are available for exchange under this program.

Contact your insurance company for further details. Your insurance company may require you to keep the child restraint for assessment, **but do not use the child restraint after a severe crash.**

Refer to the Britax Crash Exchange website for more details.

Our Crash Exchange Terms and Application form are accessible on our website. Please visit [britax.com.au](http://britax.com.au)/[britax.co.nz](http://britax.co.nz) for further information.



## In Case Of Accident

### Notice To Insurance Company Child Restraint Involved In An Accident

All Britax Safe-n-Sound® child restraints are manufactured to Australian/New Zealand Standards AS/NZS1754-2013 which require us to advise users of child restraints to "Destroy the entire restraint if it has been in use in a severe crash, even if no damage is obvious". The joint Australian/New Zealand Standards committee CS/85, advise that this statement applies whether a child was in the child restraint or not. A severe crash, we consider as being one where the main body structure of the vehicle is distorted.

There is no method of determining if the restraint has been damaged and we concur with the Australian/New Zealand Standards in recommending destruction of the child restraint.

This notice is to advise you of the requirements of the Australian/New Zealand Standards and our obligation in complying with the standards.

Please assist the owner of this restraint in their claim.

#### Australia

Britax Childcare Pty. Ltd.

A.B.N 55 006 773 600

Head office and registered address:

Level 4, 650 Lorimer Street, Port Melbourne, VIC, 3207

P.O. Box 5119 Garden City, VIC, 3207

Customer Service 1300 303 330

Email [aunz-support@britax.com](mailto:aunz-support@britax.com)

[britax.com.au](http://britax.com.au)

#### New Zealand

Britax Childcare (NZ) Ltd.

Customer Service 0508 688 822

Email [nzoffice@britax.com](mailto:nzoffice@britax.com)

[britax.co.nz](http://britax.co.nz)

#### International Enquirers

Contact your local Distributor

Britax and Britax Safe n Sound are registered trademarks of

Britax Childcare Pty Ltd. ABN 55 006 773 600

# Warranty

## Australian Consumer Law

On all of our goods, you have the benefit of a statutory consumer guarantee. In summary, goods are guaranteed to be of “acceptable quality” (fit for purpose), goods are guaranteed to match any sample against which they are sold. These consumer guarantees are provided for by the Australian Consumer Law and, if you believe any one of these guarantees is not satisfied by a Britax product, you have rights under the Australian Consumer Law to enforce that guarantee.

Your rights under the statutory consumer guarantees are set out in the **Australian Competition and Consumer Commission’s Consumer Guarantees – A Guide for Consumers**.

In addition to the statutory consumer guarantees, **Britax** offers its own company warranty on all of its products. You therefore have the option of seeking redress for defective or faulty product either under the **Britax** company warranty or the statutory guarantees.

After the **Britax** company warranty expires, you still have your rights under the statutory consumer guarantees.

Under the Britax company warranty, you are entitled to a replacement or refund for a major failure and compensation for any other reasonable foreseeable loss or damage. You are also entitled to have the goods repaired or replaced if the goods fail to be acceptable quality and the failure does not amount to a major failure. For the full terms of the Warranty refer to the **Britax** website or contact our customer service team on:

**Australia:** 1300 303 330 / **New Zealand:** 0508 688 822

## International Warranty

Britax products are available through a network of retailers in Australia and New Zealand. If you are an international customer we do not offer a warranty service outside of these regions.

THIS PRODUCT IS NOT INTENDED FOR COMMERCIAL USE

# Warranty

## Did you know?

**Registering your product online simplifies proof of purchase in the event of a warranty claim.**

Head to our website to fill out the product registration form:

[britax.com.au](http://britax.com.au) [britax.co.nz](http://britax.co.nz)



## Making A Warranty Claim

Your rights under a **Britax** company warranty are separate from and independent of your rights under the statutory consumer guarantees. What you need to do to enforce your rights under a statutory consumer guarantee is set out in the **Australian Competition and Consumer Commission’s Consumer Guarantees – A Guide for Consumers**.

To make a claim under a **Britax** company warranty, please contact our customer service team on:

**Australia:** 1300 303 330

**New Zealand:** 0508 688 822

or alternatively by email at: [aunz-support@britax.com](mailto:aunz-support@britax.com)

### You will be required to :

- Return the product to the place of purchase or to a designated repair agent;
- Present your receipt as proof of purchase;
- Identify the defect in the product; and
- Present the product to **Britax** for inspection on request.

**Britax** will advise you whether the product is covered by the **Britax** company warranty. **Britax’s** decision of whether a product is covered by a **Britax** company warranty is final. **Britax** will act reasonably when determining whether a product is covered by a company warranty.



Series No. BS3600B-Z20133

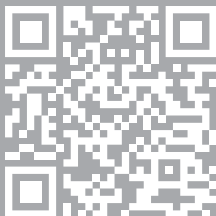

Scan QR code for  
features, how to use  
and installation.

This product may be covered by Australian and International patents and designs or pending applications. Britax Safe-n-Sound®, Safe-n-Sound®, Babylove® and Hipod® are registered trademarks of Britax® Childcare Pty Ltd. All Britax Safe-n-Sound®, Safe-n-Sound®, Babylove® and Hipod® model names are trademarks of Britax® Childcare Pty Ltd.

**P/No.2203908/A**