

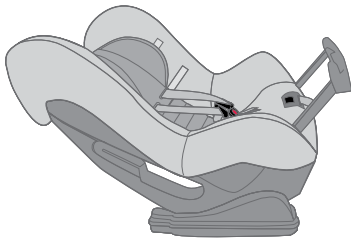

Convertible Child Restraint

Series No.7300/A/2010, 7300/D/2010



Rearward Facing

For use with children up to approximately 12 months.

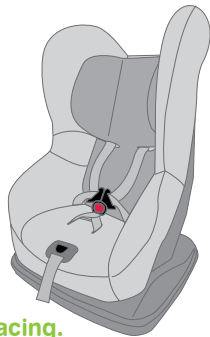

Forward Facing.

For use with children from approximately 12 months to approximately 4 years of age.

Instructions for Installation & Use



IMPORTANT: KEEP THIS BOOKLET IN THE PLACE PROVIDED ON THE CHILD RESTRAINT

Page

3	INTRODUCTION
4	WARNINGS
6	SHOULDER HEIGHT MARKERS AND A GROWING CHILD
7	SHOULDER HEIGHT MARKERS
8	SHOULDER HEIGHT MARKERS & THE NEXT STEP
9	SUITABLE FOR USE - REARWARD-FACING
10	SPECIAL FEATURES - REARWARD-FACING
12	HOW TO SETUP - REARWARD-FACING
15	HOW TO INSTALL - REARWARD-FACING
24	HOW TO USE - REARWARD-FACING
28	SPECIAL FEATURES - FORWARD-FACING
30	SUITABLE FOR USE - FORWARD-FACING
31	HOW TO SETUP - FORWARD-FACING
34	HOW TO INSTALL - FORWARD-FACING
38	HOW TO USE - FORWARD-FACING
41	CARE & MAINTENANCE
46	ACCESSORIES
49	TRAVELLING TIPS
51	INSTALLATION OF CAR ANCHOR FITTING
55	IN CASE OF ACCIDENT

This instruction book covers various models under the series number 7300/A/2010, 7300/D/2010 design. These child restraints are installed in the rear of the car and can be used either rearward-facing for infants or forward facing for older children. They are installed in the car using the car seatbelt and the tether strap attached to the car's child restraint anchor fitting.

To be used only in a rearward-facing position for an infant until their shoulders reach the lower shoulder height marker (approximately 12 months of age). Then to be used in forward-facing position until their shoulders reach the upper shoulder height marker (approximately 4 years of age).

Continue to use this child restraint until the child reaches this limit.

Do not use forward facing until child's shoulders are above the lower shoulder height marker.

Infants are at risk of serious injury if they face forward too early.

Children are at risk of serious injury if they move to booster seats too early.

Children that have outgrown this restraint are safest in a booster seat until their shoulders reach the upper shoulder height marker of the booster seat.

CAREFULLY READ ALL THE INSTRUCTIONS FOR INSTALLATION. IN THE EVENT OF DOUBT ABOUT THE METHOD OF INSTALLATION, CONSULT BRITAX CHILDCARE OR AGENT OR A CHILD RESTRAINT FITTING STATION AUTHORISED BY A RELEVANT TRANSPORT AUTHORITY OR, IN NEW ZEALAND, THE AGENT FOR THE VEHICLE.

No child restraint can guarantee absolute protection from injury in every crash. However, to ensure that your child gets all the protection designed into the restraint PLEASE READ AND FOLLOW THESE INSTRUCTIONS EXACTLY and use only Safe-n-Sound (Britax) recommended parts and accessories.

THIS RESTRAINT MUST BE ATTACHED TO A CHILD RESTRAINT ANCHORAGE POINT IN THE CAR. REFER TO CAR OWNER'S HANDBOOK FOR LOCATION OF ANCHORAGE POINTS. REFER TO A CHILD RESTRAINT FITTING STATION IF NO ANCHORAGE POINTS ARE IN THE MOTOR CAR.

TO BE USED WITH A LAP-SASH OR LAP-ONLY SEAT BELT IN THE BACK OF MOST CARS WITH FORWARD FACING SEATS.

Always store the instruction book in the pocket provided on the side or back of the cover.

WARNINGS

- Use the restraint exactly as shown in the instructions.
- Fit the restraint firmly to the car seat.
- Fit the harness firmly to the child.
- A loose restraint or harness is dangerous.
- Supervision of children is needed because they may be able to undo buckles and adjusters.
- DO NOT LEAVE CHILDREN UNATTENDED IN THE CAR.
- Do not alter or modify this restraint.
- Repairs must only be done by the manufacturer or agent.
- Do not allow the restraint to come into contact with polishes, oils, bleach and other chemicals.
- Destroy the restraint if it has been in a severe crash, even if no damage is visible.
- DO NOT USE THIS RESTRAINT WITHOUT A COVER.
- Regularly check the restraint components, straps & other fitments for correct function and condition. Seek prompt repair.
- To ensure baby's back is evenly supported do not put more than one nappy on the baby and make sure the nappy is not thickly folded at the back.
- DO NOT USE A REAR-FACING CHILD RESTRAINT WHERE AN AIRBAG IS FITTED IN THE FRONT OF THE SEATING POSITION.
- If an airbag is fitted in the desired seating position where the child restraint is to be fitted, follow the vehicle manufacturer's warnings and instructions.
- The restraint should not be purchased or sold as a second hand item. It is recommended not to use child restraints older than 10 years as the protection in an accident may be reduced.
- THIS RESTRAINT IS NOT SUITABLE FOR USE WHERE THE ANCHORAGE STRAP MAY FALL INTO A SPLIT IN THE SEAT BACK (E.G. HATCHBACK OR WAGON).

WARNINGS

- The restraint is not intended to be a substitute baby cot or bed. It is only designed to enable safe transportation of children in motor vehicles. Do not leave a baby in the restraint for long periods of time.
- Straps may be damaged by unsecured cargo in a collision. Secure or remove hazardous cargo before using this strap. Hatchback or wagon: Do not use the child restraint where the upper anchorage strap may fall into a split in the seat back.
- Protect all webbing from abrasion and cutting by sharp corners and edges.
- Do not lift the seat by the Headrest.
- Do not store in areas that may get hot, like in car boots, roof space, beside shed walls which get hot in summer. Do not place heavy items on top of the seat as this may distort the plastic.

WARNING:

DO NOT LEAVE CHILDREN UNATTENDED IN THE CAR.

SHOULDER HEIGHT MARKERS A GROWING CHILD

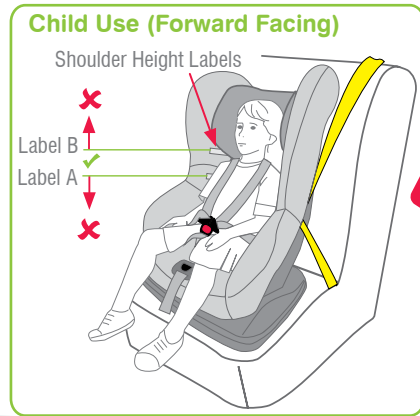
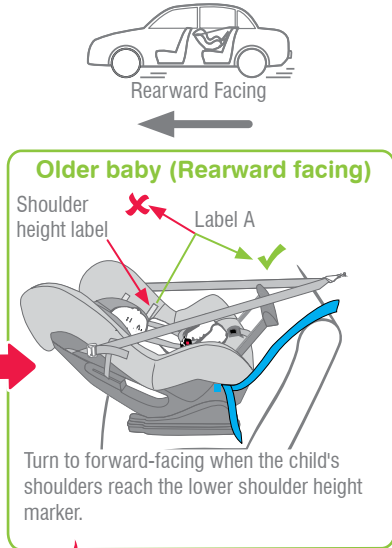
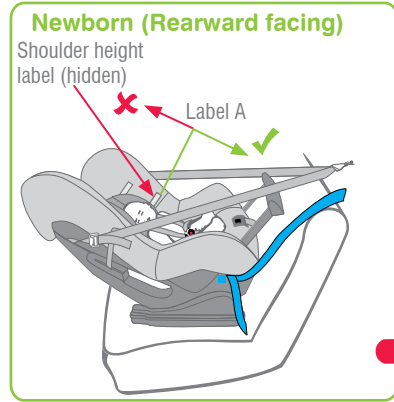

SHOULDER HEIGHT MARKERS

Shoulder height markers are provided on this restraint for a visual indication that the child is safe to ride in this restraint. Do not turn to forward-facing until the child's shoulders reach the lower marker. Do not continue to use the restraint if the child's shoulders are above the top marker.

! IMPORTANT: FOLLOW THIS ADVICE.

LOWER SHOULDER HEIGHT MARKER : Label A

When the child's shoulders reach the lower marker, the child restraint must be turned to face towards the front of the vehicle or move the child to another Forward Facing seat with in built harness. Approximately 12 months of age.

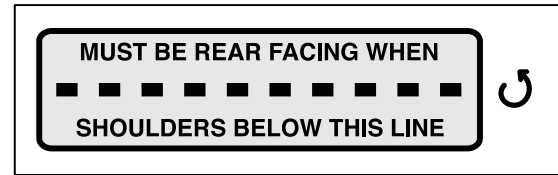

UPPER SHOULDER HEIGHT MARKER : Label B

When the child's shoulders reach this upper marker, the child is now too big for the child restraint. It is now time to move too the next child restraint. Approximately 4 years of age.

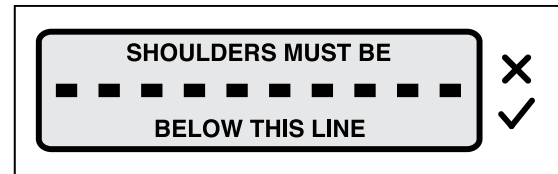

SHOULDER HEIGHT MARKERS & THE NEXT STEP

For the next child restraint choose from:

- Convertible Booster Seat (Note: you can move to a convertible booster seat once the child's shoulders reach the lower shoulder height marker), this will be a little lower than the Lower Shoulder Height Marker on the child restraint covered on the previous page.



Convertible Booster seat used with internal harness until approximately 4 years and then as a booster seat.

OR

- Booster Seat and an accessory Child Harness (A Child Harness must be used if the car is fitted with a lap only seat belt in the desired seating position),



Booster seat and accessory Child Harness.

OR

- Booster seat and lap-sash seat belt.

NOTE: These options are from approximately 6-8 years and 8-10 years.

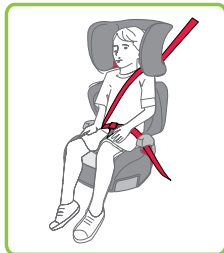

Booster seat with lap-sash seat belt.

SUITABLE FOR USE - REARWARD-FACING

TO BE USED WITH A LAP SASH OR LAP ONLY SEAT BELT IN THE BACK OF MOST CARS WITH FORWARD-FACING SEATS.

To be used only in a rearward-facing position for an infant until their shoulders reach the lower shoulder height marker (approximately 12 months of age). Then to be used in forward-facing position until their shoulders reach the upper shoulder height marker (approximately 4 years of age).

Continue to use this restraint in this rear facing mode until the child's shoulders reach the limit of the lower shoulder height marker before turning the seat to face forward. A baby's neck muscles may be unable to support their head thus the baby should remain rear facing until the neck muscles become stronger.

The purchaser should check the measurements between the front of the seat back of the rear seat and all front seats in the car in which the child restraint is intended to be used, to ensure that the space is sufficient. If you have the restraint check it fits in your car.

Regional Road Rules may prohibit the use of this restraint in the front seat until the child is 4 years of age. Check your Regional Road Rules for exemptions.

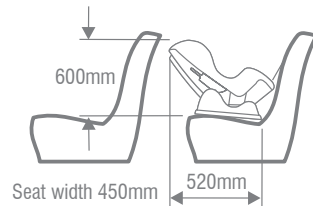

⚠ WARNINGS

DO NOT USE RESTRAINT IN REARWARD FACING MODE WITHOUT STABILISING BAR FULLY EXTENDED.

Do not use the restraint without the Upper Anchorage Strap correctly attached.

DO NOT USE A REAR FACING CHILD RESTRAINT WHERE AN AIRBAG IS FITTED IN FRONT OF THE SEATING POSITION.

Do not use on any vehicle seat which faces sideways or rearwards.

Never leave babies or toddlers in a stationary car in the sun because of the risk of heat exhaustion. Ensure babies and toddlers have adequate ventilation and are shaded from direct sunlight through side or rear windows.



Do not allow the front seat to alter the installed position of the restraint. It is permissible to allow the restraint to touch the seat on front of it.

SPECIAL FEATURES - REARWARD-FACING

To be used only in a rearward-facing position until the infant's shoulders reach the lower shoulder height marker (approximately 12 months of age).



Shoulder Height Markers may be hidden under headrest in lowest position.

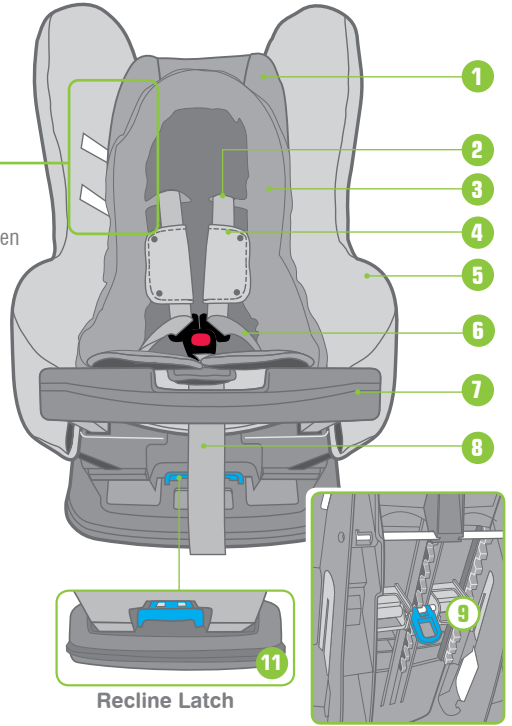

1. Adjustable Headrest with HASSLE FREE HARNESS™
2. Fully adjustable 6 point harness
3. Insert Pad (if fitted) (may vary in style)
4. Shoulder Pads (if fitted)
5. Padded cover for comfort
6. Quick Release Buckle (Red button)
7. Stabilising Bar for Baby use
8. Harness Adjustment Strap
9. Headrest adjuster latch
10. Shoulder Height Markers (May be hidden behind headrest)
11. Recline Latch

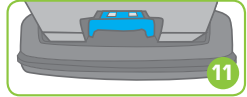

Recline Latch

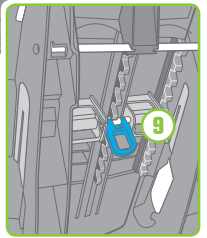

(Harness strap not shown)

SPECIAL FEATURES - REARWARD-FACING

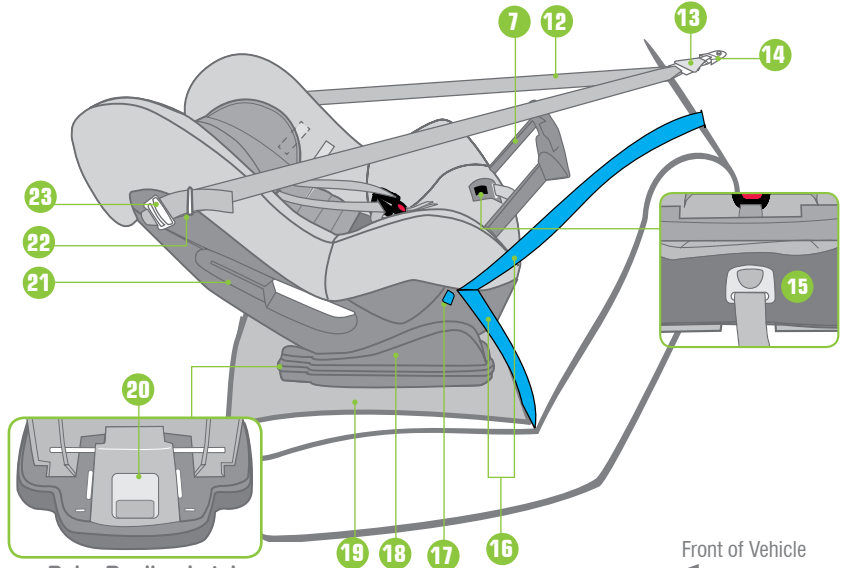

Baby Recline Latch
For rearward-facing mode only

12. Adjustable Upper Anchorage Strap
13. Attachment Clip
14. Car's Anchor Fitting
15. Harness Adjustment Button
16. Car's seat belt
17. Blue **REARWARD FACING BELT PATH** label
18. Base (shown in baby use mode)

19. Messy Mat™
20. Baby Recline Latch (back of seat for rear-facing mode only)
21. Upper Lock-off
22. Upper Anchorage Storage Band
23. Upper Anchorage Strap Adjuster

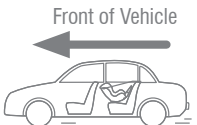

HOW TO SETUP

CONVERT TO BABY USE MODE

A. To fully recline the restraint into Child use mode, place one hand on the front corner of the base firmly, lift recline latch up to unlock, continue pulling restraint forward until fully reclined or unable to recline further.

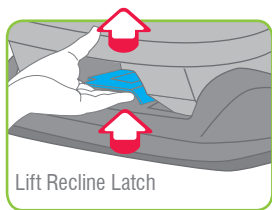

B. Once fully reclined in Child use mode, pull the baby recline latch located behind the restraint body, continue pulling the restraint forward until fully reclined into baby use mode.

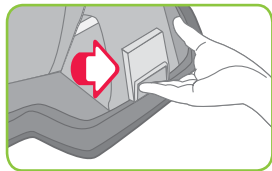

HOW TO SETUP

ADJUSTING HASSLE FREE HARNESS™ STRAP HEIGHT & HEADREST: FOR BABY USE REARWARD-FACING

Correct fitment of the harness is very important as it restrains the baby in the restraint. The Headrest must be in the correct position & the harness must fit firmly around upper torso of the baby and be positioned so as to leave the baby's arms and legs free.

For babies in rear facing mode the headrest must be in the position where the **top** of the shoulder strap slots are nearest to the child's shoulders, but not lower than the child's shoulders. Instructions for adjusting the headrest is on the next page. If your baby has reached the lower shoulder height marker then the restraint may be converted for forward-facing "child use". (Refer to Forward Facing section from page 28.)

1. The shoulder straps must be in the slots which are nearest to the child's shoulders, but not lower than the child's shoulders. There is only one set of slots so the seat will always have the shoulder straps in place once the headrest is positioned correctly.
2. The Insert pad may be used for rearward facing or in baby mode for small babies.
3. Discontinue the use of the insert pad if there is insufficient room for the baby or shoulders have reached the lower shoulder height marker.

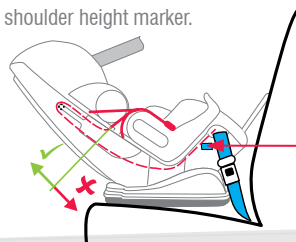
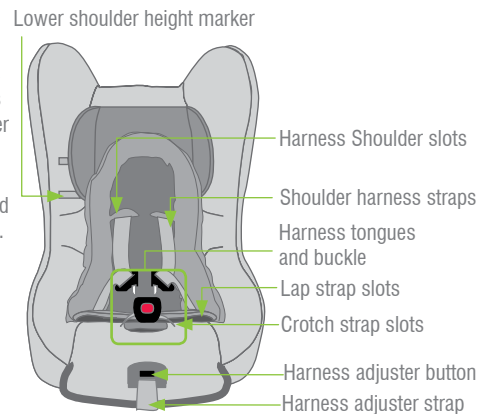

**REARWARD-FACING
BELT PATH;**
shown as blue.

HOW TO SETUP

HOW TO ADJUST HEADREST & HASSLE FREE HARNESS™

- Loosen the harness straps before adjusting the Headrest.
- You do not need to remove the restraint from the vehicle to adjust the harness or Headrest positions. Small adjustments maybe possible with the baby still in the seat.
- To adjust the Headrest, pull on the latch on the back of the restraint and pull up or down to position the top of the shoulder strap slot above the baby's shoulders. Release the latch to lock the headrest in position. Pull headrest upwards to check it is locked in position.

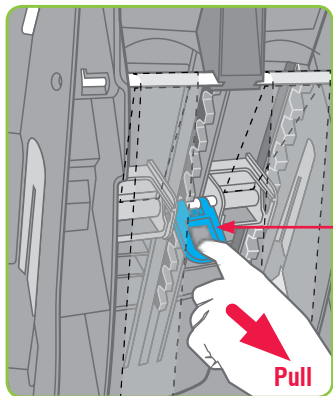

Latch

Pull

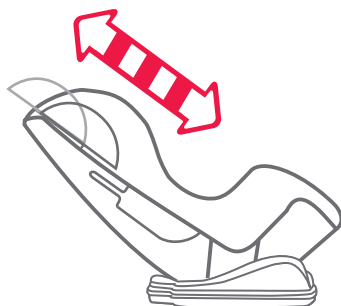

(Harness straps not shown for image clarity)

IMPORTANT:

Ensure harness and Headrest are positioned so that the shoulder straps are just above the baby's shoulders but no lower.

HOW TO INSTALL

INSTALLING INTO VEHICLE (REARWARD FACING)

The restraint is normally packaged in the fully upright child use mode so if you need to use it for baby use you must first fully recline the restraint, and then convert the restraint to baby use mode as shown below.

If Upper Anchorage Strap is folded up for storage under Storage Band then lengthen. Fully press Adjuster Button (A) while pulling Upper Anchorage Strap (B) to lengthen.

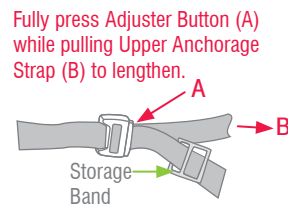

CONVERT TO BABY USE MODE

- To fully recline the restraint in Child use mode, place one hand on the front corner of the base firmly, push recline latch up to unlock, continue pulling restraint forward until fully reclined.
- Once fully reclined in Child use mode, pull the latch located behind the restraint body, continue pulling the restraint forward until fully reclined into baby use mode.

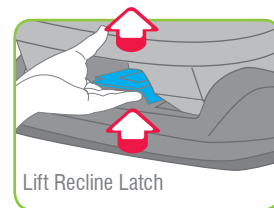

Lift Recline Latch

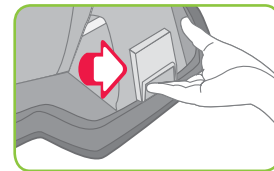

HOW TO INSTALL

INSTALLING INTO VEHICLE (REARWARD FACING) Continued

- A. Position restraint rearward facing in the chosen seating position.
- B. Lift the flap at the end of the seat sufficiently to access the stabilising bar, pull out stabilising bar and then gently push bar forward until a click is heard. Stabilising bar is now latched in place. Refit the cover. See Fig 1.
- C. Undo the buckle and place the straps to each side.

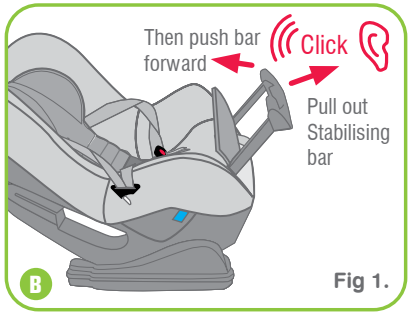
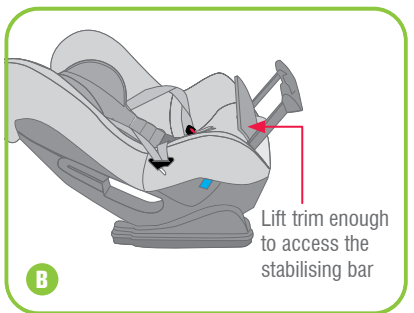

HOW TO INSTALL

- D. Remove Insert Pad (if fitted), and gently lift Headrest trim end, then pull backwards the centre panel flap, with the comfort pad from the inner seat of trim. See Fig 2.

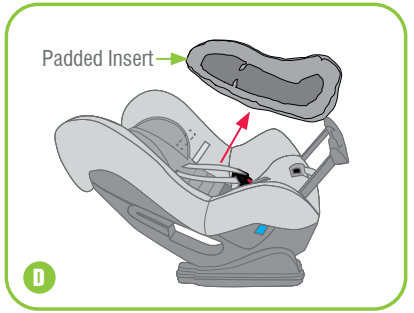

- E. Fully lengthen seat belt and feed the seat belt between the restraint cover and the restraint body through seat belt slots in restraint. See Fig 2.

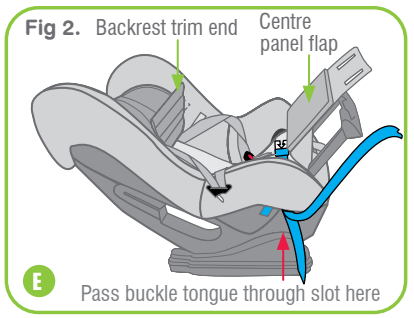

HOW TO INSTALL

- F. Engage seat belt buckle & tongue and tighten the seat belt allowing the sash to fully retract.

NOTE: Seat belt buckle and tongue must not rest between restraint cover and restraint. If seat belt buckle is adjustable, adjust buckle as low as possible away from the restraint.

- G. Replace the centre panel properly, ensure the harness buckle is through the panel, and connect the hook and loop to retain the cover. Then place back the Headrest trim end along the Headrest. For smaller babies replace the Insert Pad (if fitted). Do not use if the child's shoulders reach the lower Shoulder Height Marker. See page 13 for advice on positioning the shoulder straps.

NOTE: Seat belt extenders should not be used if the seat belt is not long enough to secure the child restraint. If they are used then the buckle must not enter the seating zone.

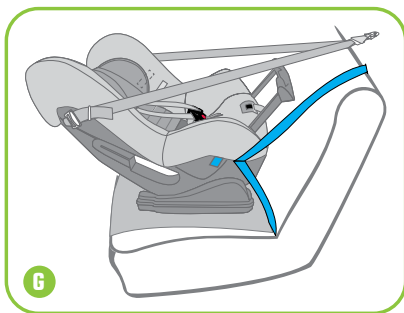
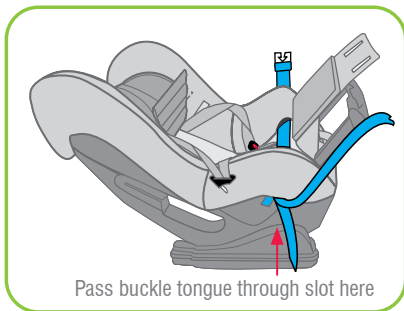

HOW TO INSTALL

- H. Align restraint centrally to the chosen seating position as shown right. Pull sash portion of seat belt until all slack is removed from Lap portion of seat belt. Adjust seat belt to hold the restraint firmly against the vehicle seat back. For retractor seat belts, allow excess belt to feed back into retractor. Lock the rear facing seat belt lock-off (if fitted) to prevent the seat belt slackening.

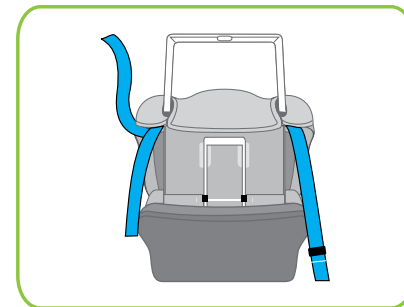

HOW TO INSTALL

- I. Fit the attachment clip to the anchor fitting as shown right. Make sure to remove as many twists as possible from the upper anchorage strap.
- J. Tighten adjustable upper anchorage strap by pulling adjustment strap to remove slack, but do not over-tighten causing the restraint base to lift off the vehicle seat. This will usually be done once the baby has been harnessed into the seat.
- K. Roll up excess strap tightly so the webbing is thick enough to be held in the storage band.

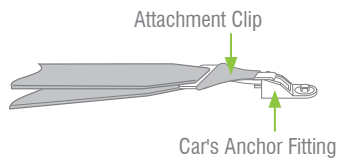

Fully press Adjuster Button (1) while pulling Upper Anchorage Strap (2) to lengthen.

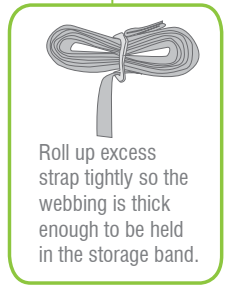
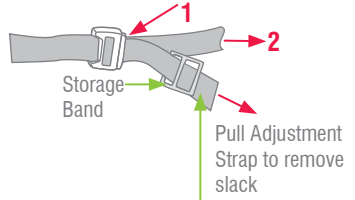

HOW TO INSTALL

Fitting Summary

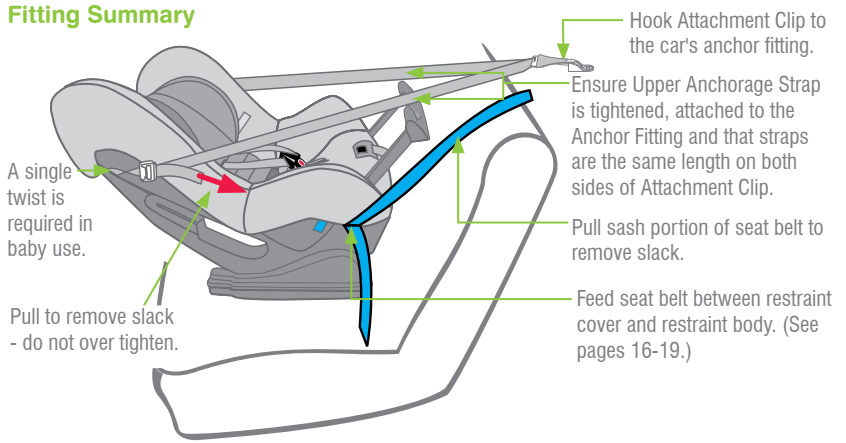

⚠ WARNINGS

- DO NOT USE THE RESTRAINT IN REARWARD FACING MODE WITHOUT STABILISING BAR FULLY EXTENDED.**
- THE UPPER ANCHORAGE STRAP MUST ALWAYS BE FITTED WHEN THE CHILD RESTRAINT IS USED IN A VEHICLE.**
- ALWAYS ATTACH THE HOOK AND REMOVE THE SLACK.**

HOW TO INSTALL

IMPORTANT:

If using an Extension Strap, positioning the Attachment Clip above the baby may lead to injury in an accident therefore make sure that the Attachment Clip is not positioned in front of the vehicle seat.

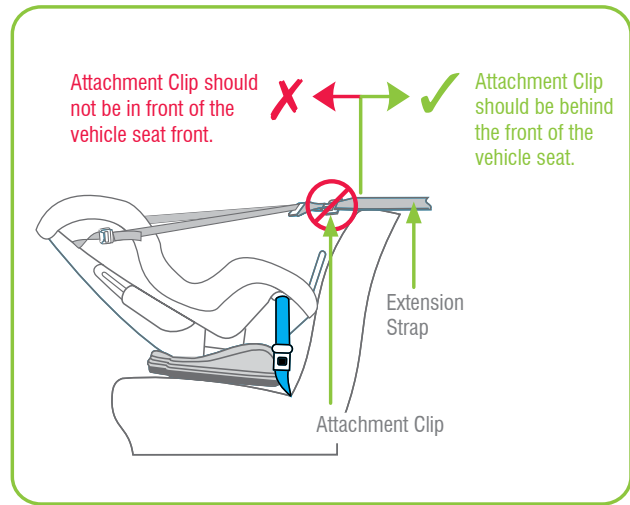

HOW TO INSTALL

ANGULAR ADJUSTMENT OF RESTRAINT

Some vehicle seats have more rearward slope than others. If the angle of the seat causes the baby to be too upright for comfort, the angle may be altered by placing a firm packing between the seat and the underside of the base. Packing can be a firmly rolled up towel or nappy.

If the car's seat is flat then some packing may be required at the front edge of the Base to achieve the recline angle.

Do not remove all of the rearward slope by over packing. Always leave a rearward slope angle of approximately 10 to 15 degrees as shown

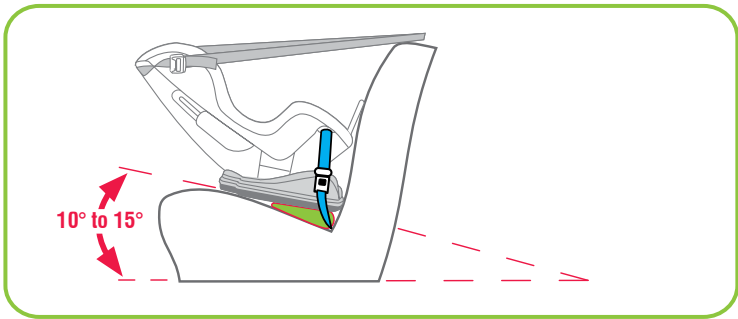

HOW TO USE

PLACING BABY INTO RESTRAINT

- Ensure the Headrest and shoulder straps are adjusted to the correct height for your child (see page 13).
- Slacken the Upper Anchorage Strap and allow the straps to fall to the sides of the restraint for easy access to the baby.
- Slacken Harness Straps by pushing and holding the Harness Adjustment Button, grasping BOTH shoulder harness straps and pulling out the desired amount of slack. Release harness adjustment button when there is enough slack and place the buckle tongues over the side of the seat so that the baby does not lay on them.
- Lay baby on their back into restraint and fit harness as shown. Make sure the baby is dressed to allow harness buckle to be pulled up between baby's legs e.g. a jump suit.

IMPORTANT: Always ensure the baby's arms and legs are free. Never wrap baby in a blanket before placing in restraint.

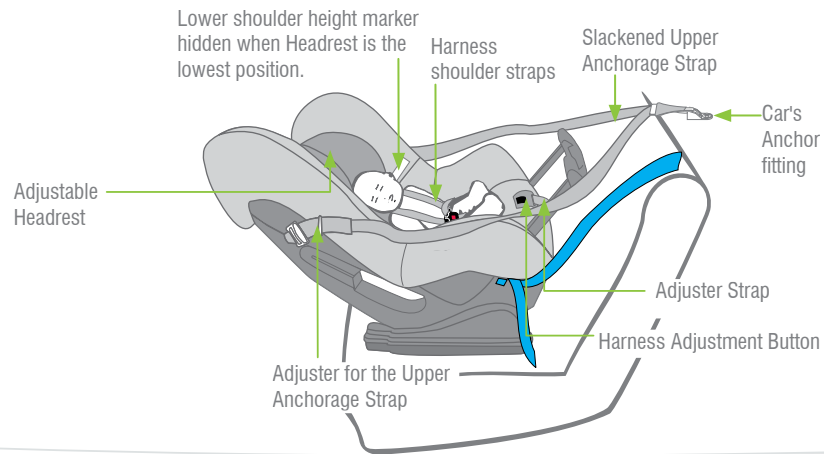

HOW TO USE

- Fit either harness tongue into the harness buckle followed by the other tongue until a click is heard. Should the second tongue not insert, press the red button and re-insert the tongues. Ensure secure engagement by pulling harness straps.
- Remove slack from harness lap straps by pulling shoulder straps.
- Adjust the harness to a firm but comfortable fit by pulling the harness adjustment strap.

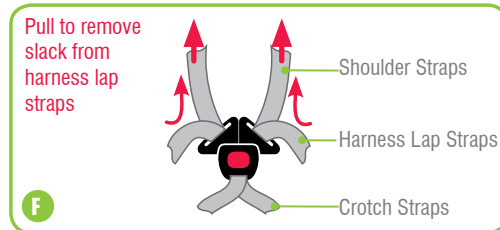
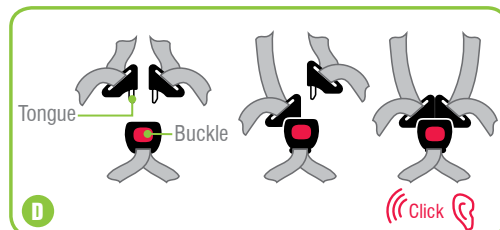

- Re-tighten the Adjustable Upper Anchorage Strap by pulling the Adjustment Strap to remove slack as shown. Roll up the excess strap tightly so the webbing is thick enough to be held in the storage band.

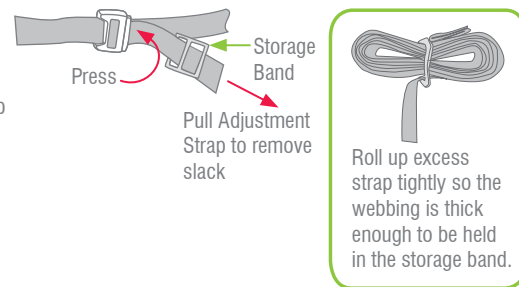

HOW TO USE

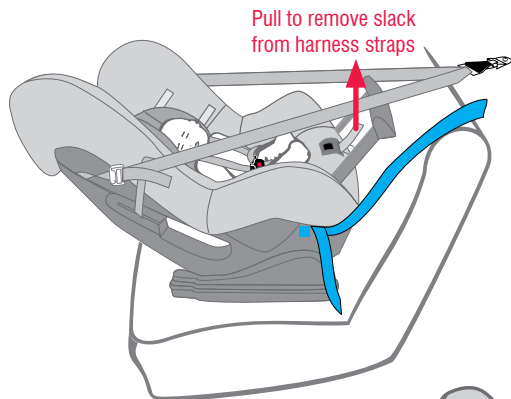

CAUTION: A LOOSE HARNESS IS DANGEROUS.

Make sure that nothing is obstructing harness straps and that baby's arms and legs are free with the straps in the correct location as shown right. Do not wrap the baby in a blanket or any other wrap.

Do not use restraint if straps do not tighten and contact Britax Childcare Customer Service. Refer to back cover for details.

IMPORTANT: The Insert Pad is designed to snugly support baby for extra support and comfort and must be used for smaller babies. Discontinue use when Baby Insert Pad is a tight fit, creates discomfort for larger babies, or the baby's shoulder reach the Lower Shoulder Height Marker or the baby is over 6 months of age.

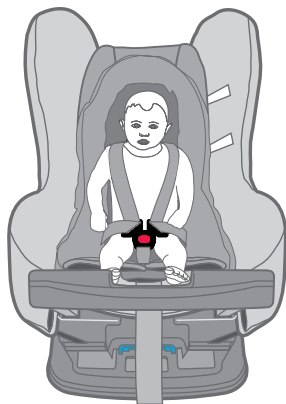

HOW TO USE

REMOVING BABY FROM RESTRAINT

- Press the Upper Anchorage Strap Adjuster Button while pulling Upper Anchorage Straps to slacken. Allow the Upper Anchorage Straps to fall to the sides for easy access into restraint.
- Lift and hold the harness adjustment lever or push and hold the Harness Adjustment Button (whichever is fitted) while pulling both Shoulder Harness Straps to slacken harness to the desired amount.
- Press the red button on Harness Buckle. Then both Harness tongues will be released. Move each shoulder strap to baby's side then pick up the baby.

TO REMOVE RESTRAINT FROM VEHICLE

- Disengage seat belt tongue from buckle and remove from the restraint.
- Fully press the Upper Anchorage Strap Adjuster Button (1) while pulling the Upper Anchorage Strap (2) to slacken as shown right. In some vehicles loosening of the Upper Anchorage Strap may be difficult. If so, try pushing the restraint against the vehicle seat back or slightly lifting the restraint to release the tension.
- Disengage Attachment Clip from the Anchor Fitting. The child restraint is now disconnected.

See page 34 for storage of the stabilising bar and the return to the upright position if required.

Fully press Adjuster Button (1) while pulling Upper Anchorage Strap (2) to lengthen.

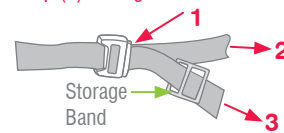

Pull Adjustment Strap to remove slack

SPECIAL FEATURES - FORWARD-FACING

To be used only in a forward-facing position by children whose shoulder's have reached the lower shoulder height marker (approximately 12 months of age) until the shoulders reach the upper shoulder height marker (approximately 4 years of age.)

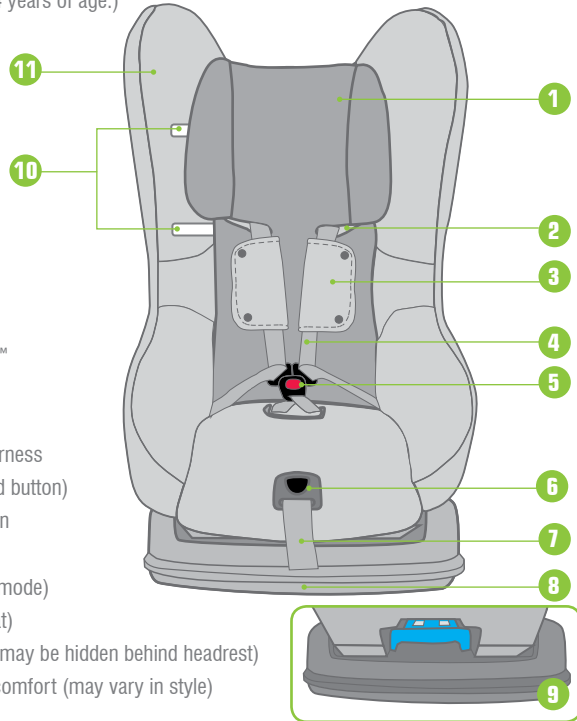

1. Adjustable Headrest with HASSLE FREE HARNESS™
2. Shoulder Harness Slots
3. Shoulder Pads (if fitted)
4. Fully adjustable 6 point harness
5. Quick Release Buckle (Red button)
6. Harness Adjustment Button
7. Harness Adjustment Strap
8. Base (shown in child use mode)
9. Recline Latch (front of seat)
10. Shoulder Height Markers (may be hidden behind headrest)
11. Padded Cover for Child's comfort (may vary in style)

Recline Latch

SPECIAL FEATURES - FORWARD-FACING

12. Car's Anchor Fitting
13. Car's seat belt
14. Upper Lock-off
15. Messy Mat™
16. Yellow FORWARD-FACING BELT PATH labels
17. Upper Anchorage Strap Adjuster
18. Upper Anchorage Storage Band
19. Upper Anchorage Adjustment Strap
20. Attachment Clip

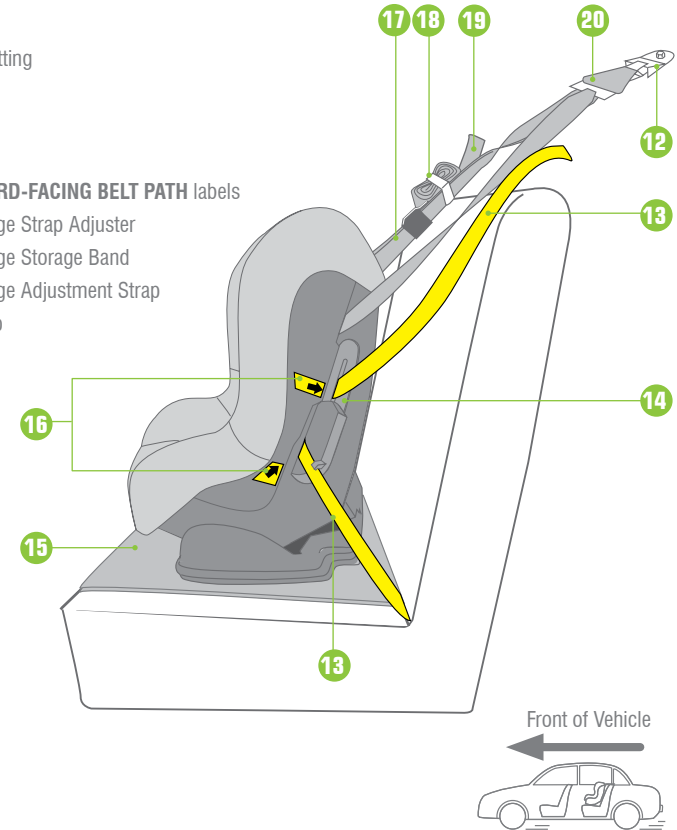

Front of Vehicle

FOR CHILD USE FORWARD-FACING

FOR CHILD USE FORWARD-FACING

TO BE USED WITH A LAP SASH OR LAP ONLY SEAT BELT IN THE BACK OF MOST CARS WITH FORWARD-FACING SEATS.

Once the child's shoulders reach the lower shoulder height marker then the seat can be changed to the forward-facing position and used until the child's shoulders reach the upper shoulder height marker.

Continue to use this restraint in this forward-facing mode until the child's shoulders reaches the limit of the lower shoulder height marker. The child should not sit forward-facing until the baby's neck muscles are able to support their head. Do not move to a Booster Seat until the child has outgrown this child restraint.

Regional Road Rules may prohibit the use of this restraint in the front seat of the vehicle until the child is 4 years of age. Check your Regional Road Rules for exemptions.

WARNINGS

DO NOT USE RESTRAINT IN FORWARD-FACING MODE WITH THE REAR FACING MODE STABILISING BAR PULLED OUT.

Do not use the restraint without the Upper Anchorage Strap correctly attached.

If your vehicle is not fitted with an anchor point, please contact a Safety Restraint Fitting Station authorised by the relevant State Government Body for correct fitment of the restraint. In New Zealand contact the agent for the vehicle. The upper anchorage strap must be attached to an anchorage point using an extension strap if necessary.

Do not use on any vehicle seat which faces sideways or rearwards.

Do not use the Insert Pad (if fitted) in Forward Facing 'Child Use'.

If an airbag is fitted in the desired seating position where the child restraint is fitted, follow the vehicle manufacturer's warnings and instructions.

Children are at risk of serious injury if they move to a booster seat too early.

CONVERT THE RESTRAINT TO CHILD USE MODE

- A. Convert the restraint to child use mode by placing one hand on the top of the restraint and using the other hand pulling the recline latch at the back of the restraint outwards. Then lift the restraint forward until audible click is heard.

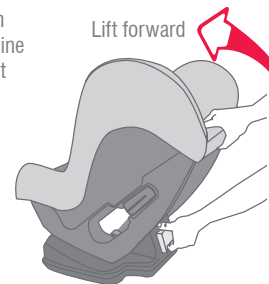

- B. Determine whether an upright or reclined position is preferred and adjust if necessary (see below).
- C. Place one hand on the front corner of base firmly, while with the other hand lift the recline latch up to unlock and push back until the restraint is at the desired position. Ensure the recline latch is engaged into position by pushing on the restraint.

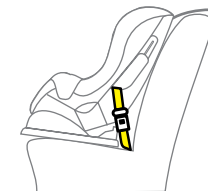
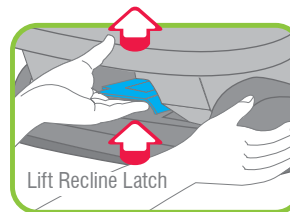

FULLY UPRIGHT
CHILD USE MODE

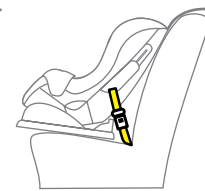

FULLY RECLINED
CHILD USE MODE

HOW TO SETUP

ADJUSTING HASSLE FREE HARNESS™ STRAP HEIGHT & HEADREST: FOR CHILD USE FORWARD-FACING

Correct fitment of the harness is very important as it restrains the child in the restraint. The harness must fit firmly around the upper torso of the child and be positioned so as to leave the child's arms and legs free.

With the headrest adjusted so that the bottom edges are just above the child's shoulders the harness will then fit closely to the child's shoulders. If the Headrest is in the top position and the shoulders are above the upper shoulder height marker then the child is too tall for the restraint and the restraint should not be used; move to next type of restraint (see pages 6 to 8).

Lower shoulder height marker

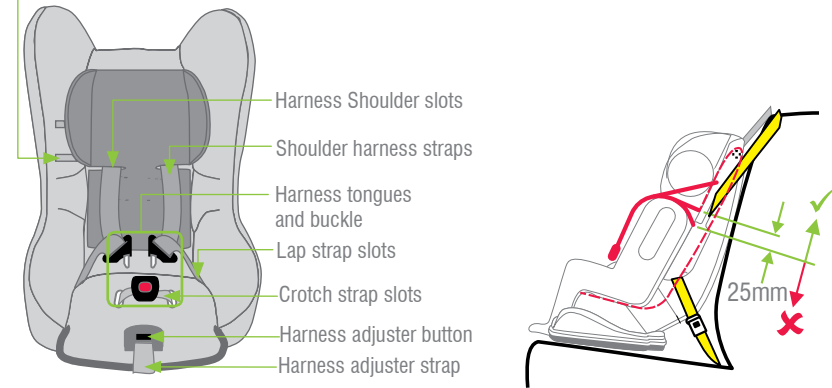

The shoulder straps must be in the slots which are nearest to the child's shoulders, but not more than 25mm below the child's shoulders. There is only one set of slots so the seat will always have the shoulder straps in place once the headrest is positioned correctly, just above the child's shoulders.

Note: This child restraint does not require the strap to be disconnected to adjust their height, only the headrest needs to be moved to adjust the shoulder strap position.

HOW TO SETUP

HOW TO ADJUST THE HEADREST & HASSLE FREE HARNESS™

- Loosen the harness straps before adjusting the Headrest.
- To make adjustments you will need to remove the child and the restraint from the vehicle or loosen the seat belt.
- To adjust the Headrest, pull on the latch on the back of the restraint and pull up or down to position the bottom of the headrest to be just above the child's shoulders. Release the latch to lock the headrest in position. Pull headrest upwards to check it is locked in position.

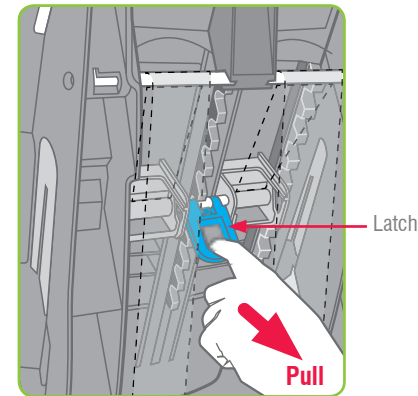

(Harness straps not shown for image clarity)

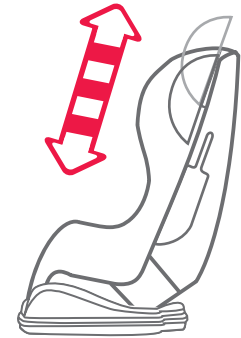

! IMPORTANT:

Ensure harness and Headrest are positioned so that the shoulder straps are just above the child's shoulders or the headrest is just above the child's shoulders.

FOR CHILD USE FORWARD-FACING

HOW TO INSTALL

INSTALLING INTO VEHICLE FORWARD-FACING (UPRIGHT OR RECLINED)

- A. Remove the seat from the vehicle by disengaging the seat belt and upper anchorage strap.
- B. Remove the Insert Pad (if fitted) as this is no longer required.
- C. To store the Stabilising Bar, lift the cover at the end of the seat which uncovers the stabilising bar storage recess.
- D. Press the button on the left side (facing seat) and gently push stabilising bar back and then down into the recessed area.
- E. Re-attach the cover at the end of the seat.

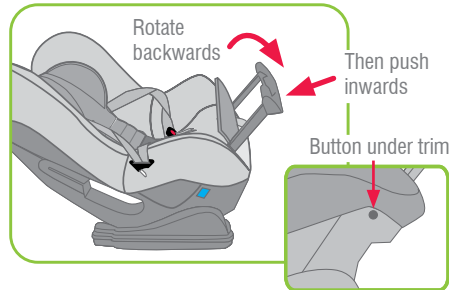
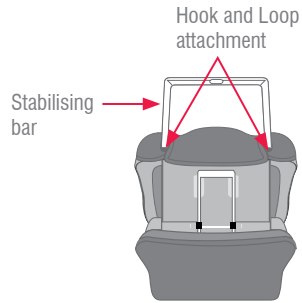

! IMPORTANT:

DO NOT USE RESTRAINT IN FORWARD-FACING POSITION WITH THE STABILISING BAR PULLED OUT.

Do not recline into baby position when using restraint in forward-facing child use mode. Ensure the harness is in the correct position (Refer to pages 32).

HOW TO INSTALL

- F. Position the restraint in forward-facing mode and align restraint centrally within the chosen seating position.
Some vehicle seat fabrics (particularly velours) may be damaged by a child restraint used continuously. We recommend the use of a full Messy Mat™ or thick towel to keep the vehicle seat in good condition.
- G. Fully lengthen seat belt. Insert seat belt tongue through the child use seat belt path (yellow path), ensuring that the seat belt is behind the harness straps and that the lap part of the seat belt is below the hooks as shown.
- H. Engage the seat belt buckle and tongue, ensure to remove all slack from the lap part of the seat belt 1 by pulling sash belt 2.
- I. Grasp the sash belt 2 between thumb and fingers in each hand and allow some slack in the belt. Now slide the slack belt up into the lock-off slot, up to the top of the slot. If the belt is not slack it will not enter the lock-off slot.
- J. Pull the sash belt 2 through the lock-off to fully tighten the seat belt. The sash belt 2 must not be tight when feeding it into the lock-off slot. The child restraint should now be firmly fitted to the vehicle seat.
Allow the excess sash belt to feed back into retractor.

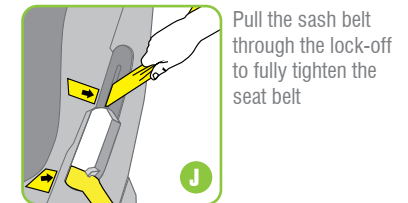
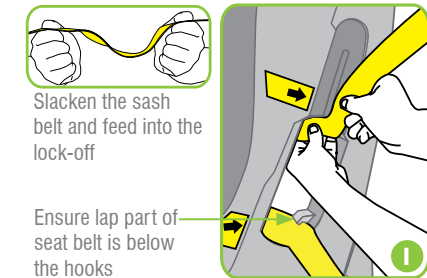
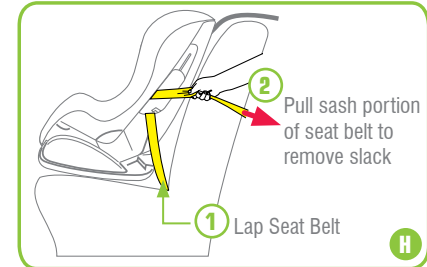

HOW TO INSTALL

- K. Fit the attachment clip on the upper anchorage strap to the anchor fitting as shown. Make sure to remove as many twists as possible from the upper anchorage strap.

WARNING

Always attach the hook and remove slack

- L. Tighten the Adjustable Upper Anchorage Strap by pulling the adjustment strap to remove slack as shown below, but do not over-tighten causing the restraint base to lift off the vehicle seat.
- M. Roll up the excess strap tightly so the webbing is thick enough to be held in the storage band.

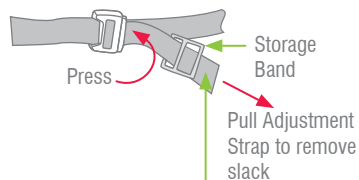
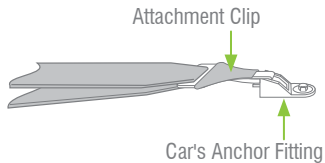

NOTE: Seat belt extenders should not be used if the seat belt is not long enough to secure the child restraint. If they are used then the buckle tongue must not enter the seat belt path.

HOW TO INSTALL

FITTING SUMMARY

IMPORTANT:
Always roll up the excess Upper Anchorage Strap.

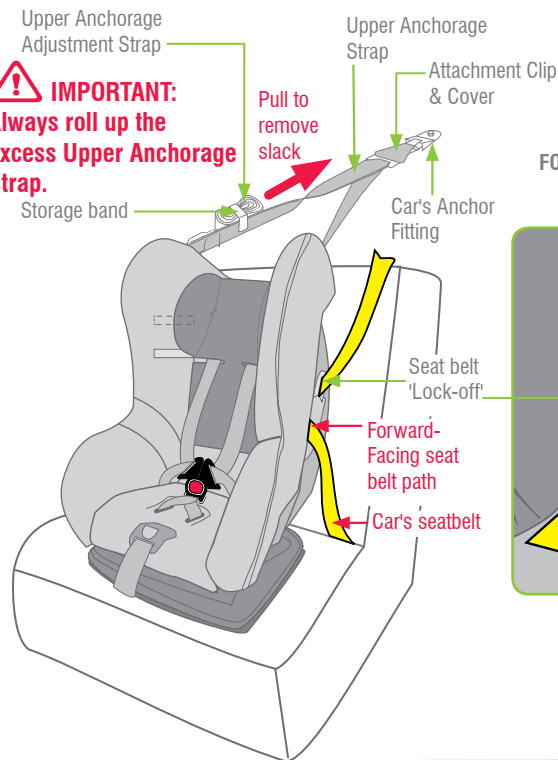

FORWARD-FACING BELT PATH;
marked in yellow.

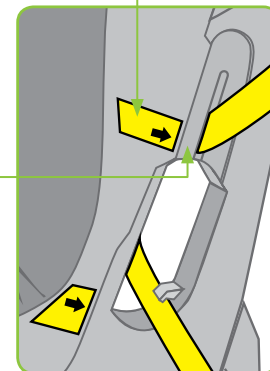

FOR CHILD USE FORWARD-FACING

HOW TO USE

PLACING CHILD IN THE RESTRAINT

- A.** Lengthen the harness by pushing and holding the Harness Adjustment Button (if fitted) while pulling on both shoulder straps until the harness is fully lengthened. Release the harness adjustment button when there is enough slack.

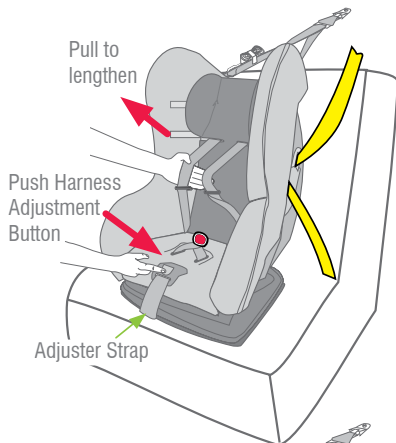

- B.** Place child in the restraint and feed each arm through shoulder straps. Pull harness buckle up between child's legs.



HOW TO USE

- C.** Fit either harness tongue into the harness buckle followed by the other tongue until a click is heard. Should the second tongue not insert, press the red button and reinsert the tongues. Ensure secure engagement by pulling the harness straps.

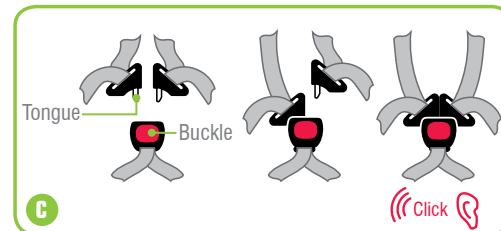

- D.** Remove all of the slack from the harness lap straps by pulling shoulder straps, then pull the harness adjustment strap to adjust harness to a comfortable but firm fit.

Check that the slack in straps is removed. The Shoulder Harness Straps must fit firmly to the child. A loose harness could result in serious injury in an accident.

Do not use restraint if straps do not tighten and contact your local authorised service agent for repair.

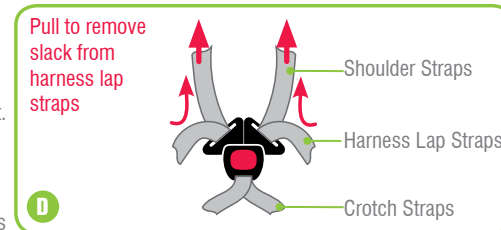

⚠ CAUTION: A LOOSE HARNESS IS DANGEROUS.



HOW TO USE

TO RECLINE RESTRAINT

The child restraint may be reclined or positioned upright without removing the child from the restraint but it is easier without the child. Lift the recline latch and push or pull to get the desired recline. There are 3 recline positions. You will be able to gain partial recline from upright position by just pushing the recline latch up and pulling the seat forward. The extent of the recline will be limited by the location of the anchorage point. Loosening of the upper anchorage strap may be required when positioning the restraint to either an upright or reclined position. Once the required position has been determined ensure to tighten the upper anchorage strap and re-check the car seat belt tension i.e., all slack to be removed.

Push recline latch up while moving restraint into desired recline position.

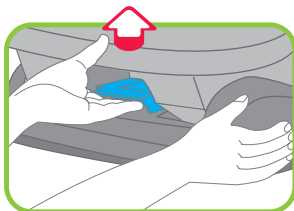

TO REMOVE CHILD

Press the red button on Harness Buckle and then both Harness tongues will be released. Lift the shoulder straps from the child's shoulders, the child can then get out.

TO REMOVE RESTRAINT FROM VEHICLE

- Disengage the seat belt tongue from the buckle and remove from the restraint. Pull the sash belt downwards to pull it out of the Upper lock-off.
- Release the stored strap and fully press Upper Anchorage Strap Adjuster Button (1) while pulling the Upper Anchorage Strap (2) to slacken as shown right. In some vehicles loosening of the Upper Anchorage Strap may be difficult. If so, try pushing the restraint against the vehicle seat back or slightly lifting the restraint to release the tension.
- Disengage Attachment Clip from Anchor Fitting. The child restraint is now disconnected.

Fully press Adjuster Button (1) while pulling Upper Anchorage Strap (2) to lengthen.

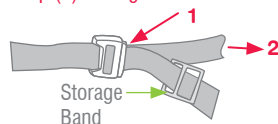

CARE & MAINTENANCE

REGULAR CARE OF THIS RESTRAINT:

Please check the following items regularly to ensure the safety of your child:

- Check the webbing for fraying,
- Check that the buckle clicks and is not sluggish or sticky in operation,
- Ensure there are no cracks in moulding or the plastic moulding,
- Check the harness adjuster is operating and is clamping the webbing,
- If any part of the restraint is cracked or broken, seek repair immediately or replace the child restraint,
- Ensure the buckle is free of fluff, liquid or other matter that may enter the buckle slots. Clean the buckle if it is sluggish to engage.

CLEANING THE SEAT

Use only mild soap and water to clean all webbing, metal and plastic parts of the restraint using a damp cloth. Do not use chemicals or cleaning agents.

TO CLEAN HARNESS BUCKLE:

If sticky liquids such as baby formula, fruit juice, etc. get inside your Harness Buckle, it may become sluggish. An indication of a sluggish Harness Buckle is that you cannot hear a click when engaging the Harness Tongues. To restore the Harness Buckle to good working order it needs to be cleaned as follows:

- From the underside of the restraint pull each crotch 3-bar slide then turn 3-bar slide and push through each slot to remove the Harness Buckle from the restraint.
- Place the Harness Buckle under warm (max. 40 degrees Celsius) running water as shown below. Let the water run through the mouth of the buckle for five minutes. Do not immerse the harness in water.

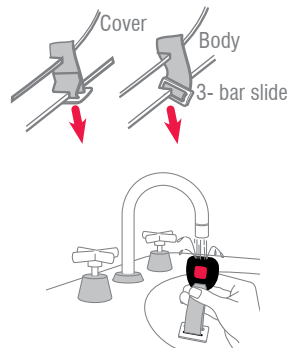

CARE & MAINTENANCE

- C. Engage and disengage the Harness Tongues and Buckles several times until a strong audible click is heard when inserting the last tongue.
- D. If you still cannot hear a strong audible click after engaging the Harness Tongues and Buckle, then repeat cleaning several times. If the Harness Buckle cannot be returned to its original working condition then contact Britax Childcare Customer Service.
- E. Refit the harness buckle to the restraint with the red button facing out and feeding each 3-bar slide through appropriate slot.

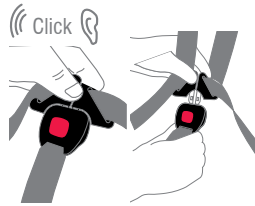

COVER (STYLE MAY VARY)

The restraint has a flame retardant cover which is removable for cleaning. Cleaning instructions are on the care label attached to the cover. If fluffy cover is fitted then washing cover prior to use will remove excess fluff.

Drying the Insert Pad will take additional time as the impact foam will absorb moisture. Before washing re-engage the hook and loop on the cover and Seat Pad to prevent the 'hook' damaging the fabric.

The cover has been designed to protect your child when seated in the restraint. Care should be taken if children either eat or drink while in the restraint as some food or drink products may cause damage or marking to the cover. Wash or clean immediately.

Do not pull sticky items from covers as the cover may be damaged - soak in water and gently remove.

! VERY IMPORTANT:

Only use this child restraint with the cover supplied or a manufacturer-authorized replacement cover with identical shoulder height markers.

CARE & MAINTENANCE

TO REMOVE COVER:

- A. Remove the restraint from vehicle.
- B. Disengage the harness tongues from the harness buckle.
- D. Remove any accessories, pillow, Insert Pad, shoulder pads (if fitted).



- E. Remove headrest cover by unclipping the press studs on the Headrest hardware, and then unhooking the elastic loop attached to the headrest cover.

Pull the headrest cover off the Headrest.

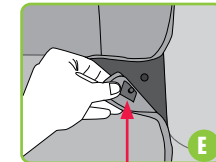

Pull to unclip press stud

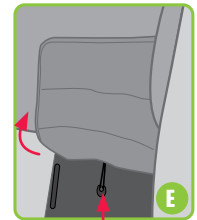

Lift lower part of the headrest cover and unhook elastic loop

CARE & MAINTENANCE

- F. Unhook the elastic loops at the top of the cover located at the back of the restraint and the elastic loops at the bottom of the restraint located under the front of the restraint.

unhook elastic loop at the back of the restraint

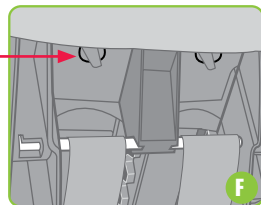

- G. Remove the cover while feeding the Crotch Buckle, Harness Tongues and strap through the lap and crotch strap slots in the cover. If fitted with a Harness Adjuster Button, peel the cover from the button housing starting at one corner.

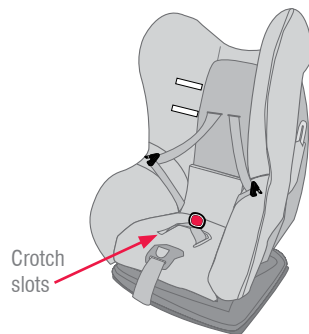

CARE & MAINTENANCE

TO REPLACE COVER:

- A. Feed the Harness Tongues and shoulder straps through the side slots in the cover.
- B. Stretch the cover over the top of the restraint first, then the sides, then stretch the cover around the rim of the restraint. Attach the elastic loops to the hooks on the restraint.
- C. Re-fit the Seat Cover attachments.
- D. Reattach the hook and loop at each side, feed the Crotch Buckle through slots in cover
- E. If fitted with a Push Button Adjuster, stretch cover over Push Button housing. Pull the adjuster strap through the cover. Ensure none of the harness straps are twisted.
- F. Fit the Headrest cover over Headrest and slide harness through slots in the seat and the cover.
- G. Refit the Insert Pad (if fitted) or other accessories if required. If the headrest has moved then reset the headrest so the shoulder straps are near the shoulder. See pages 13 Rearward-facing and 32 Forward-facing.
- H. Refit to the vehicle.

Hook elastic loop at the back of the restraint

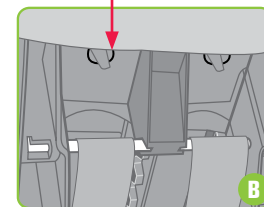

Reattach the hook and loop on the cover

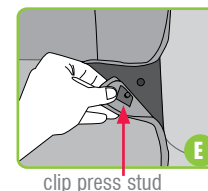
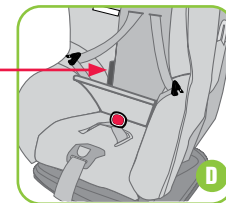

clip press stud

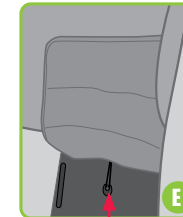

Hook elastic loop

ACCESSORIES

IMPORTANT:

ONLY USE SAFE-N-SOUND SEAT COVERS AND ACCESSORIES THAT ARE DESIGNED AND TESTED FOR USE WITH THIS PRODUCT.

The following instructions apply to accessories that may be supplied with this restraint at point of purchase. If not, a variety of accessories are available from various retailers of Safe-n-Sound products.

SHOULDER PADS (IF FITTED)

Shoulder Pads are designed to provide extra comfort for baby or child and are easily fitted to the shoulder harness straps by:

- Pull apart fasteners and remove shoulder pads from harness.
- Re-fit shoulder pads to harness and attach fasteners for use.

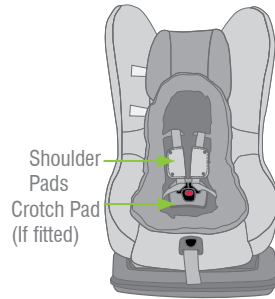

CROTCH PAD (IF FITTED)

The Crotch Pad is designed to provide extra comfort for baby or child and is fitted to the restraint as follows: Feed the Crotch Buckle through the slot in crotch pad.

POCKETS (IF FITTED)

The pockets sewn on the trim are designed for your convenience. They can hold those necessary items that you need at a moments notice. e.g. Bottle, face washer, toy etc. They can also hold a CD or MP3 player.

CAUTION:

If using the pocket to store filled bottles, please ensure contents are not contaminated due to prolonged storage. Ensure contents are not crushed by car door when closing.

ACCESSORIES

INSERT PAD - STYLE MAY VARY

The Insert Pad is designed to snugly support baby for extra support and comfort and should be used for small babies when rearward-facing. Discontinue use when the baby insert pad is tight fit or creates discomfort for larger babies or when the baby's shoulder's reach the lower shoulder height marker. Do not use baby insert pad for babies over 6 months of age. Do not use when in Forward Facing mode. Fit as follows:-

- Disconnect buckle and place insert under shoulder and lap straps.
- Feed the crotch strap through the flap in the Insert Pad and re-connect buckle.

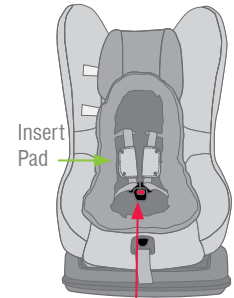

Pull crotch strap through flap in Insert Pad.

CUP HOLDER (IF SUPPLIED)

To fit the cup holder to the restraint, insert the locating tabs through the pair of holes on either side of the restraint. Slide the cup holder down until it locks into position. To remove, press the release trigger on the bottom of the cup holder, then slide up and out of the holes in the restraint. Ensure the cup holder and its contents can not be crushed by the car door. Store the cup holder when not in use.

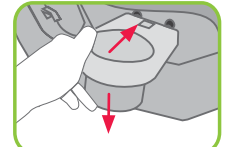
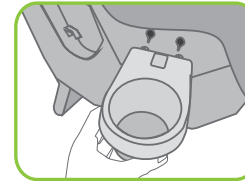

Slide cup holder into the slots and then down, until it locks into position



WARNING:

Only use for holding cups, bottles and drink cartons. Do not use for hot drinks.

MESSY MAT™ (IF SUPPLIED)

The Messy Mat's has been specifically designed to protect your vehicle seat from damage by the child restraint and children's shoes rubbing against it. If the Messy Mat has been supplied it must be used to protect the car upholstery.

Place pocket on edge of seat, smooth back toward seat join ('A') and fit in any excess Messy Mat into the join of the car seat ('A').

CAUTION:

The Messy Mat pocket is only for small, light items. DO NOT overload the pocket with heavy, bulky items as this may damage the pocket or cause passengers to trip over them.

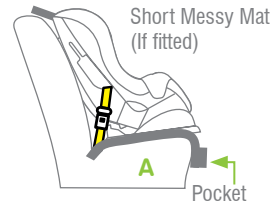
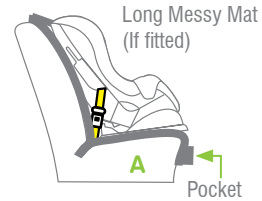

Note: Some Messy Mats may not have pockets.

SAFETY

Never hold a baby in arms when riding in a motor vehicle. In this position the baby could be thrown against the dashboard, windscreen or other occupant and suffer serious injury or death.

When riding in a motor vehicle, never nurse a baby and use the same seat belt for both of you. In this position the baby or child could be crushed.

Children must be secured in appropriate restraints at all times when the car is in motion. Children travelling unrestrained and standing up in the car are in danger of serious injury or death. Traffic regulations in all states require children to be secured in child restraints or adult seat belts where available.

Plan your trip with frequent comfort stops to reduce stress on babies, young children and driver. Keep the car well ventilated to reduce heat stress. Two car windows should be kept open to maintain a good flow of fresh air if air conditioning is not used.

Never leave babies or toddlers in a stationary car in the sun because of the risk of heat exhaustion.

Ensure babies and toddlers are adequately shaded from direct sunlight through side or rear windows. Be on guard against carbon monoxide poisoning which can occur through only a slight leak in the exhaust system while travelling in a closed car.

Securely stow all heavy objects, feeding bottles, etc. that could become missiles during an accident and cause injury to any occupant.

TRAVELLING TIPS

CLOTHING/BATHING

Take several changes of clothing and bibs for possible car sickness. Disposable nappies and liners are very handy while travelling. Since it is often warmer in the car, dress the baby in light clothing. When cooler, it is easier to place a blanket over the baby than it is to remove the baby from the restraint and change clothes.

FEEDING

Never breast feed a baby while car is in motion. Babies will require extra feeding if travelling in the heat. For bottle fed babies, make up the bottles and refrigerate before leaving home for a day trip. Place in a cool bag and reheat as needed with hot water from a thermos.

Alternatively, bring boiled water in a thermos and pre-measured amounts of baby formula in small containers. Use the water from the thermos to mix with the formula when required. Regardless which method is used, it is always a good plan to carry some boiled water in a sterile container or bottle.

Do not attempt to carry warm milk because germs multiply rapidly in warm milk.

INSTALLATION OF CAR ANCHOR FITTING

Consult the vehicle owner's handbook for location of anchorage fittings or anchorage points and the possible use of spacers. Some vehicles may have an anchor fitting fitted by the vehicle manufacturer. If anchorage points cannot be found refer to car manufacturer or local child restraint fitting station or traffic authority for optimum position of anchorage point and the use of spacers.

UPPER ANCHORAGE STRAP



IMPORTANT:

THE ATTACHMENT CLIP COVER MUST ALWAYS BE USED AS IT PREVENTS THE RISK OF INCORRECT FITMENT OF THE ATTACHMENT CLIP TO THE ANCHOR FITTING. ALWAYS ENSURE THAT THE ATTACHMENT CLIP IS CORRECTLY ENGAGED TO THE ANCHOR FITTING AND NOT HOOKED OR FITTED TO ANY OTHER OBJECT BEFORE EACH USE OF THE RESTRAINT. THIS IS ESPECIALLY IMPORTANT IN VEHICLES SUCH AS STATION WAGONS, VANS, HATCH BACKS OR VEHICLES WITHOUT A FIXED PARCEL SHELF, SINCE THE ANCHOR POINT IS USUALLY NOT VISIBLE.

IMPORTANT INSTALLATION NOTE:

In some vehicles the anchor fitting in the rear vertical panel can only be installed in one way. Please refer to vehicle owner's handbook or a child restraint fitting station for correct method.

INSTALLATION OF CAR ANCHOR FITTING

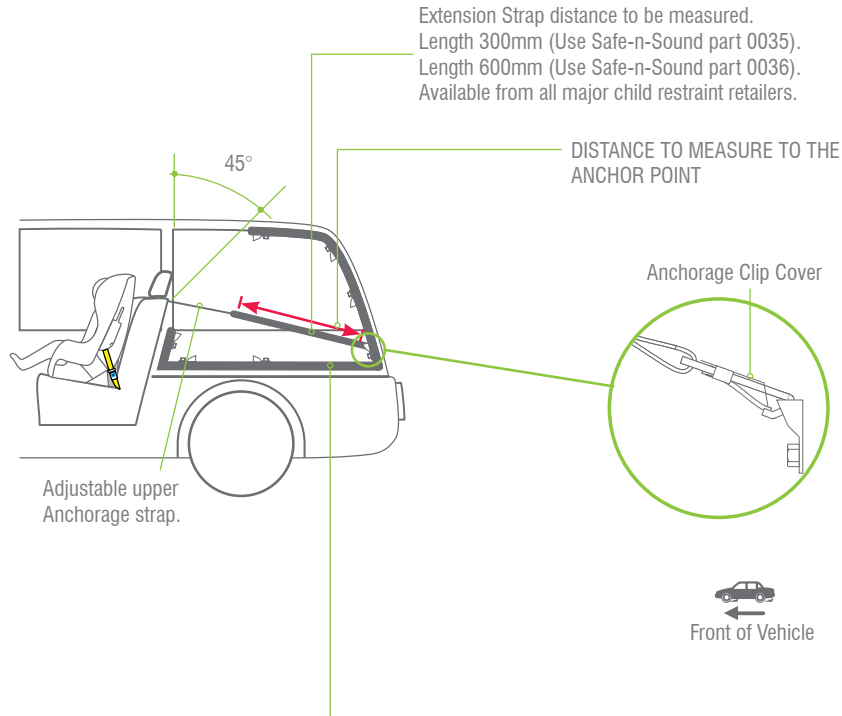

The shaded areas of this diagram illustrate the possible locations of the anchor fitting. Within each shaded area is an anchor fitting showing the correct way to install the fitting. Ensure the anchor fitting is aligned as illustrated unless stated otherwise in the vehicle owner's handbook.

INSTALLATION OF CAR ANCHOR FITTING

IF THE CAR IS FITTED WITH CHILD RESTRAINT ANCHORAGE POINT

Locate the anchorage point behind the rear seating position. (consult the car owners handbook for the location of the anchorage point). The anchorage point should be directly behind and central to the restraint. Remove thread plug from the parcel shelf/floor/roof, etc. and install anchor bolt and fitting as shown in Fig 1.

CAUTION: DO NOT OVERTIGHTEN ANCHOR BOLT. OVERTIGHTENING MAY FRACTURE OR BREAK BOLT. MAXIMUM TORQUE IS 20 Nm (14.75 ft.lb.)

Note: Minimum of five full turns of anchor bolt is required before tightening force is applied.

IF THE CAR IS NOT FITTED WITH CHILD RESTRAINT ANCHORAGE POINTS

For Sedans only - Drill 9mm diameter hole in the parcel shelf on the centre line of the seating position as shown in Fig 3. Before drilling the hole, check the underside for accessibility. Install the anchor bolt as shown in Fig 2.

For vehicles other than Sedans - In Australia, consult your nearest child restraint fitting station or traffic authority for vehicle inspection to find the best, correct position for the placement of the anchorage point, and for the correct attachment bolt length and use of spacers. In New Zealand, consult the agent for the vehicle.

Note to Queensland purchasers: The installation of anchorage points must be approved by authorised officers appointed by Queensland Transport. Authorised officers can be sourced from all Queensland Transport Customer Service and Queensland Ambulance Service Centres.

UPPER ANCHORAGE FITTING

Fig.1.

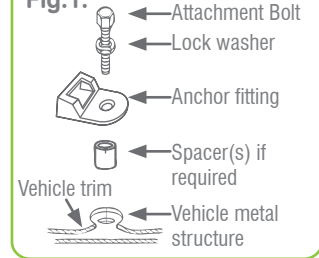

UPPER ANCHORAGE FITTINGS FOR SEDANS ONLY

Fig.2.

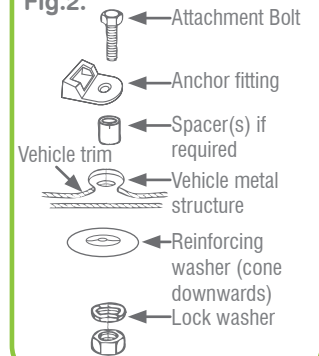

INSTALLATION OF CAR ANCHOR FITTING

ONLY USE A 5/16 UNC GRADE 5 BOLT. IF THE BOLT IS NOT THE CORRECT LENGTH THE CAR MANUFACTURER'S HAND BOOK CAN PROVIDE ADVICE ON THE CORRECT LENGTH BOLT.

WARNING

CHILD RESTRAINTS MUST NOT BE ATTACHED TO UNSOUND METAL OR TO WOOD, OR SYNTHETIC STRUCTURES. WHEN DRILLING 9 MM HOLE DO NOT DRILL THROUGH FUEL LINES, FUEL TANKS, ELECTRICAL WIRING, OR RADIO SPEAKERS. WEBBING STRAPS MUST BE PROTECTED FROM SHARP CORNERS AND EDGES. THE ANCHOR FITTING MUST BE USED ONLY AS DESCRIBED ABOVE. IT MUST NOT BE HOOKED ONTO ANY OTHER OBJECT.

CAR INSTALLATION ACCESSORIES (From retailers of Safe-n-Sound products)

EXTRA ANCHOR KITS: Available for using the restraint in additional cars.
Re-order no: 0038

EXTENSION STRAPS: May be required for cars without a fixed parcel shelf.
Re-order no: 0035 (length 300mm) or
0036 (length 600mm)

GATED 3-BAR SLIDE (Locking clip): For converting lap-sash seat belt to lap belt, and to obtain a better fit to the car where the fitted lock-off may not be suitable. Most cars will not need this.
Re-order no: 0215.



Note: Marking on the top of a Grade 5 Bolt.

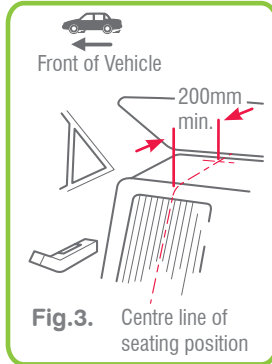

Fig.3. Centre line of seating position

IN CASE OF ACCIDENT

If your restraint has been involved in a severe crash, you should destroy the restraint even if no damage is obvious. Some insurance companies offer vehicle insurance which covers or partially covers the replacement of your child restraint. Contact your insurance company for further details. Your insurance company may require you to keep the child restraint for assessment, **but do not use the child restraint after a severe crash**. To assist you in making an accident insurance claim cut the following statement and include it with your claim.

NOTICE TO INSURANCE COMPANY CHILD RESTRAINT INVOLVED IN AN ACCIDENT

All Safe-n-Sound child restraints are manufactured to Australian/New Zealand Standards AS/NZS1754-2010 which requires us to advise users of child restraints to "Destroy the entire restraint if it has been in use in a severe crash, even if no damage is obvious". The joint Australian/New Zealand Standards committee CS/85, advise that this statement applies whether a child was in the child restraint or not. We consider a "server crash" as being one where the main body structure of the vehicle is distorted. There is no method of determining if the restraint has been damaged and we concur with the Australian/New Zealand Standards in recommending destruction of the child restraint. This notice is to advise you of the requirements of the Australian/New Zealand Standards and our obligation in complying with the standards. Please assist the owner of this restraint in their claim.

Britax Childcare Pty. Ltd.

(Incorporated in Victoria)
A.B.N 55 006 773 600
Head office and registered address:
99 Derby Road Sunshine Victoria 3020
PO Box 147 Sunshine Victoria 3020
Telephone: 1300 303 330

www.britax.com.au

New Zealand Office
Britax Childcare NZ Limited.
Telephone: 0508 688 822

www.britax.co.nz



CRASH EXCHANGE

We would never want you to experience an accident, but unfortunately accidents do happen.

If you experience an accident you may be eligible for a free replacement.

The Safe-n-Sound Crash Exchange Program is a voluntary program designed to ensure that our children are safe and that any seat that may have experienced a severe crash is taken out of the market.

There is no method of determining if the restraint has been damaged in a severe crash, so the restraint should be destroyed as the crash may reduce the child restraints ability to perform.

Since its inception in 2006, the Crash Exchange program has helped 100's of families ensure that their children have new restraints and that the restraints are not sold second hand placing others at risk.

Our Crash Exchange Terms and Application form are accessible on our website. Please visit www.britax.com.au for further information.





AUSTRALIA

Britax Childcare Pty. Ltd.
A.B.N 55 006 773 600

Head office and registered address

99 Derby Road, Sunshine, Victoria 3020.
PO Box 147 Sunshine, Victoria 3020.

Customer Service 1300 303 330

Email au-custserv@britax.com

www.britax.com.au

NEW ZEALAND

Britax Childcare (NZ) Ltd.

Customer Service 0508 688 822

Email nz-custserv@britax.com

www.britax.co.nz

INTERNATIONAL ENQUIRIES

Contact your local Distributor.

The Safe-n-Sound trademark is the property of Britax Childcare Pty. Ltd. (Australia).

The Britax trademark is the property of Britax Excelsior Limited (UK).

We reserve the right to alter this product without notice.

© 1995-2011 Britax Childcare Pty. Ltd. This product is covered by Australian and overseas Patent applications. Patents pending.