

click & goTM bassinet

signature

Compatible with **Strider Signature V5** and
Strider Mini Signature strollers.

(All products are sold separately)



0 - 9kg

(newborn - 6 months approx.)

IMPORTANT KEEP THIS BOOKLET IN A SAFE
PLACE FOR FUTURE REFERENCE

SERIES PB2004 | britax.com.au
britax.co.nz

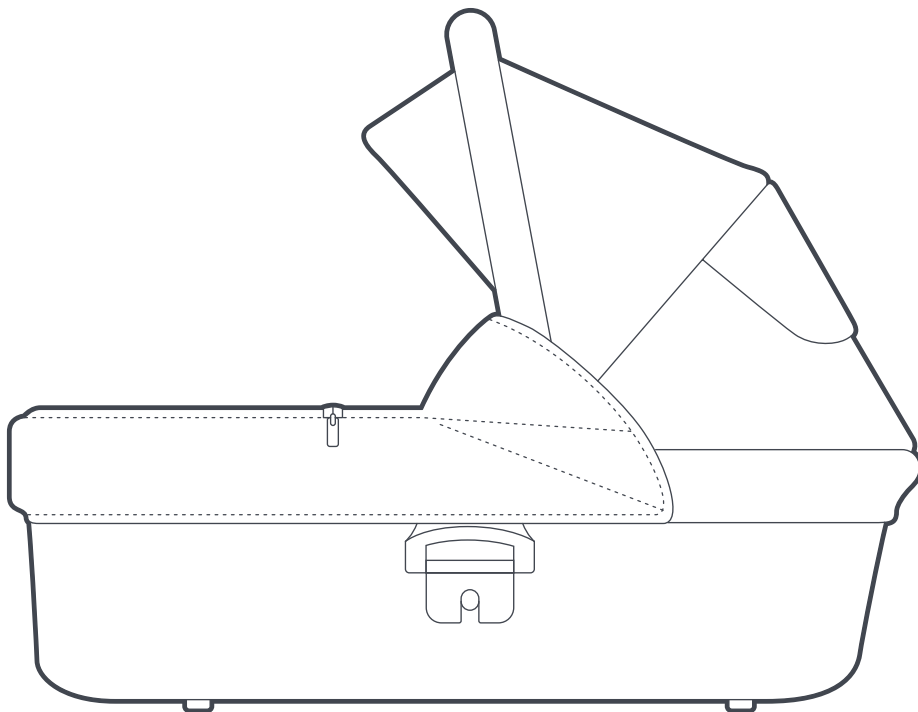

 **Steelcraft**

Warnings & Important Notes

WARNINGS

- **DO NOT USE THE BASSINET ONCE THE CHILD CAN SIT UP.**
- **IT IS UNSAFE TO USE ACCESSORIES NOT APPROVED FOR USE WITH THIS STROLLER.**
- **DO NOT USE ANY ACCESSORIES OTHER THAN THOSE APPROVED FOR USE WITH THIS STROLLER BY BRITAX.**
- **THE MAXIMUM WEIGHT OF THE CHILD USING THIS PRODUCT IS NOT TO EXCEED 9KGS.**
- **DO NOT USE FOR UNSUPERVISED SLEEPING**

IMPORTANT NOTES:

- Click & Go™ Signature Bassinet is designed to fit Steelcraft Strider Signature V5 and Strider Mini Signature strollers.
- Remove the stroller seat or baby capsule from the frame before fitting the bassinet.
- Always remove your child from the bassinet before fitting or removing the bassinet from the stroller frame.
- The bassinet must always be on parent facing mode (facing handlebar).
- The bassinet must be removed from the frame before folding.
- Do not lift the stroller by the bassinet.

Lift & Carry Correctly

The **SMART** lifting technique: This technique can be used to pick up small light loads from low levels.

Size up the load

- Assess the load (size, shape, and weight).
- Assess whether the load needs to be moved;
- Where is it going to be placed? Check that there are no obstructions;
- Assess whether mechanical or human assistance is required.

Move the load as close to the body as possible

- A load is heavier to lift or carry if it is not close to the body.
- The whole hand should be used to ensure a firm grip.

Always bend your knees

- Maintain balance.
- Keep feet apart and in a comfortable position.
- Minimise lower back bending.
- Bend knees preferable at as large an angle as possible but not at a right angle - use a semi-squat in preference to a full squat.

Raise the load with your legs

- Achieve the lift smoothly and without jerkiness.
- Maintain the normal curvature of the spine to allow the force of the load to be distributed evenly from the spine to the pelvis.

Turn your feet in the direction that you want to move the load.

- Avoid unnecessary bending, twisting, and reaching.
- Change direction by turning your feet and not your back.
- To set the load down, squat down, keep your head up and let your legs do the work.

Remember to **THINK TALL** - chest lifted, shoulders relaxed, chin tucked in, and head level.

What's in the Box: Parts

1 x Bassinet Frame

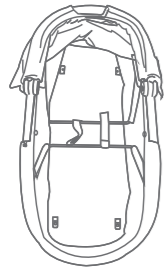

1 x Bassinet Liner

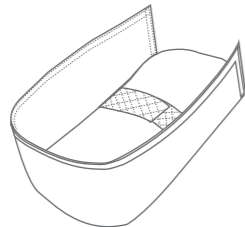

1 x Bassinet Boot Cover

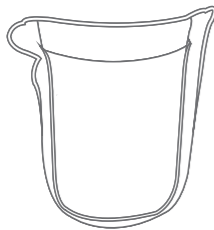

1 x Bassinet Mattress with Removable Reversible Seasonal Cover



Compatible with:

- Strider Signature^{V5}
(with Click & Go™ Adaptors - included with stroller)
- Strider Mini Signature
(no adaptors required)

IMPORTANT NOTE: For the most up to date compatibility please refer to our compatibility list at:

Australia: britax.com.au
New Zealand: britax.co.nz

Bassinet Features

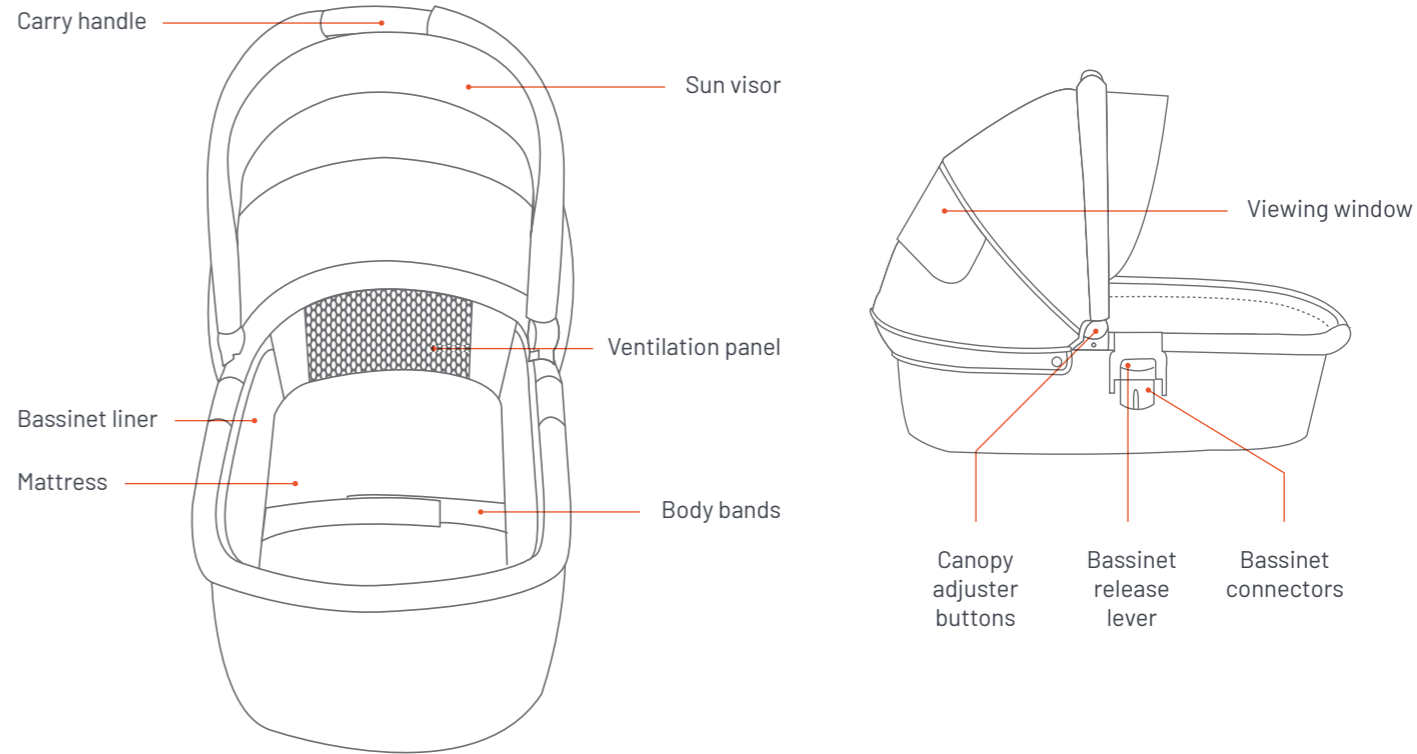

Bassinet Assembly

Opening the Bassinet Canopy

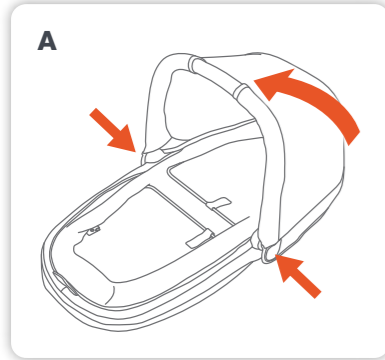

A Rotate the canopy to the upright position by pressing in and holding the canopy adjuster buttons on both sides.

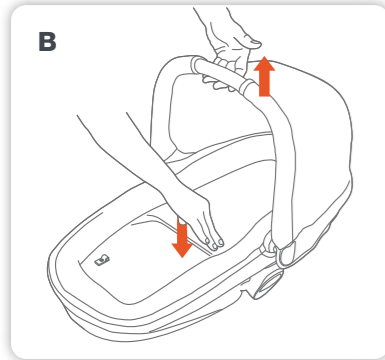

B Press down on the base of the bassinet & pull up on the canopy handle to raise the sides.

Opening the Bassinet Frame

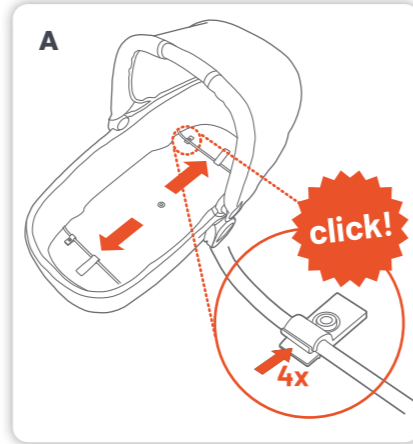

A Pull the bassinet frame support rods outward by the straps until each rod slides and locks under all 4 clips. Push down lightly on the top edges of the bassinet to ensure that the frame support rods are firmly locked in place.

Bassinet Assembly

Attaching the Liner

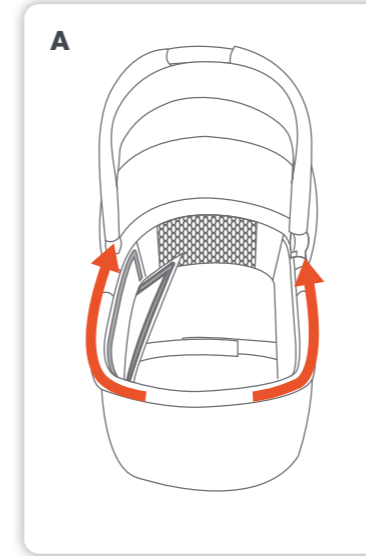

A Place the liner in the bassinet and attach the hook and loop around the bassinet.

Inserting the Mattress

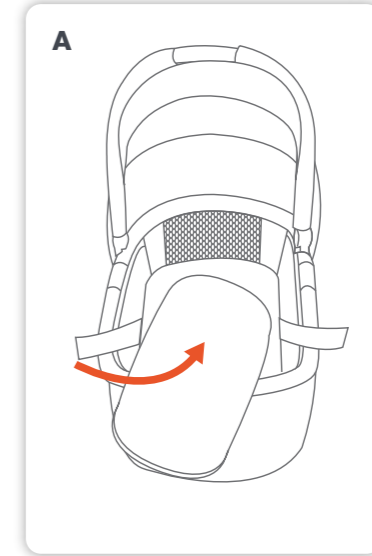

A Place the mattress into the bassinet. Place the body band on the top surface of the mattress.

Bassinet Operation

Using the Canopy

⚠ CAUTION: ENSURE THE CANOPY IS SECURELY ENGAGED BEFORE YOU LIFT THE BASSINET BY THE HANDLE.

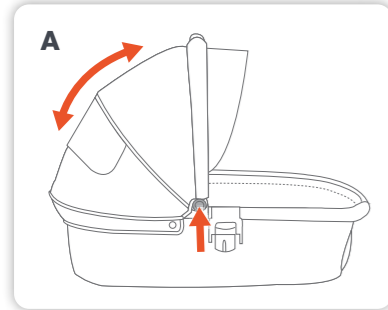

A Fasten 3 canopy hook tabs to the base located on the rear and both sides of the canopy. Press the canopy adjuster buttons on both sides and to rotate the canopy to the desired position.

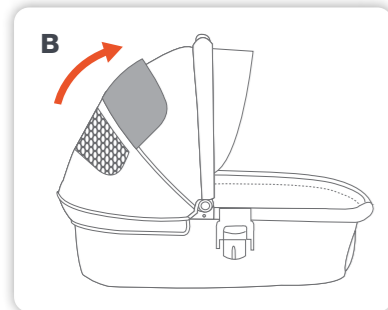

B There is a viewing window for ventilation and observation.

Attaching the Boot Cover

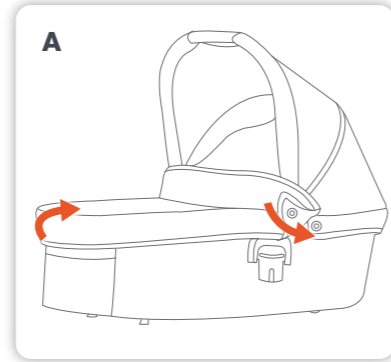

A Place the bassinet boot cover over the bassinet and snap the press studs on each side of the boot cover to the each side of the canopy.

Bassinet Operation

Attaching the Bassinet to the Stroller

IMPORTANT NOTE:

- Always remove your baby from the bassinet before installing or removing the bassinet.
- Always remove the bassinet before folding.

PLEASE NOTE: The bassinet can only be installed rearward position (parent facing) on the stroller frame. Must use each compatible stroller with correct **Click & Go** adaptors.

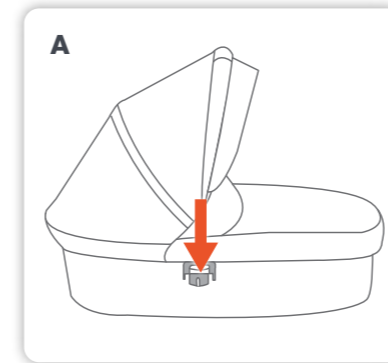

A Align the bassinet directly over the **Click & Go** adaptors and push down until it locks. Pull up on the bassinet to ensure it is locked.

Removing the Bassinet from the Stroller

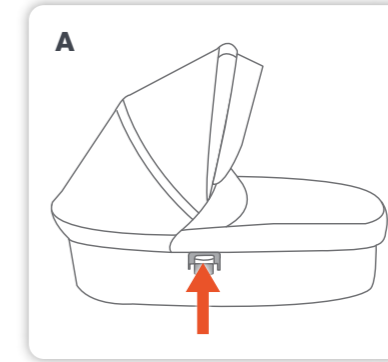

A Holding and lifting the bassinet release buttons on both sides and lift the bassinet up and away from the stroller.

Bassinet Operation

Using the Body Band

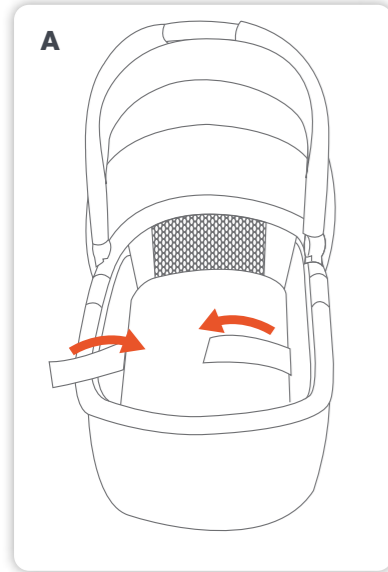

A Place the mattress into the bassinet. Place the body band on the top surface of the mattress. Place the baby band around the baby's abdomen close to the body without constricting the baby and carefully fasten the two sides of the body band with the hook and loop strips.

✔ **TIP:** The body band can be used for additional safety.

Using the Ventilation Panel

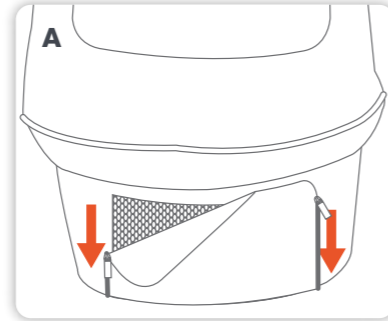

A Unzip the zippers on both sides to reveal the ventilation mesh.

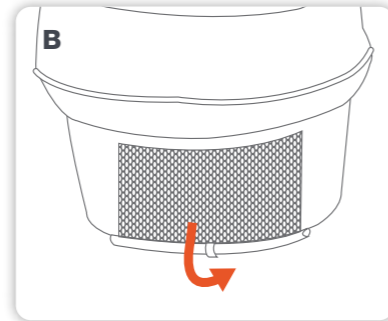

B Fasten the ventilation panel with hook and loop.

✔ **TIP:** The ventilation panel can be opened to cool and provide more air flow to the baby.

Bassinet Operation

Attaching the Rain Cover

Sold Separately

IMPORTANT NOTE:

- Ensure the rain cover is kept away from the child's face.
- Refit the rain cover if required to ensure your child is safe.

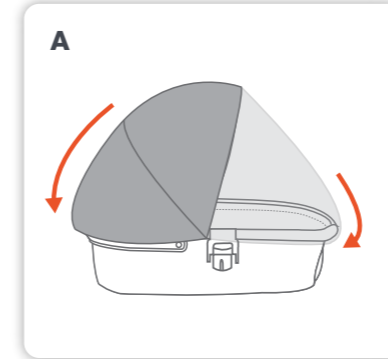

A Fit the rain cover over the canopy and pull to the front then secure with elasticised end.

Attaching the Sun Shade

Sold Separately

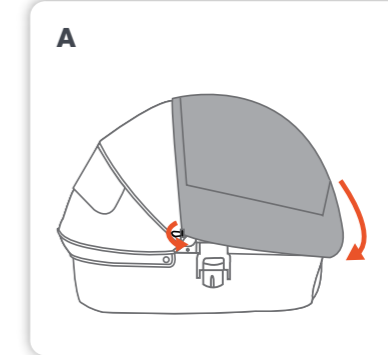

A Fit the sun shade over the canopy front and secure the toggle and elastic loop around the canopy frame then pull to the front and secure with elasticised end.

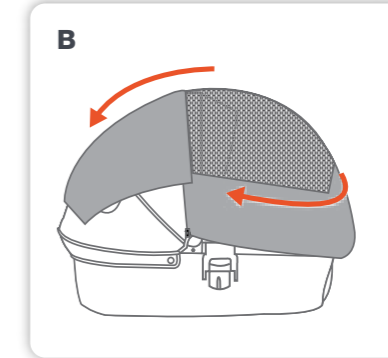

B Lift the sun shade cover flap to use mesh panel for ventilation and open zipper to access the baby.

Care & Maintenance

General Maintenance & Repair

- Ensure all safety devices, locks, harness, and brakes are in working order.
- Ensure all joints and folding areas move freely as intended.
- Should any moving or locking parts become stiff or hard to operate, ensure these are free from tension, or dirt by wiping clean with a damp cloth to remove any dirt, sand, or debris. Allow to dry and lightly spray with a dry silicon lubricant. Please carefully read the lubricant instructions prior to use.
- Ensure wheels are regularly cleaned with a damp cloth by removing dirt, sand, or debris. Allow to dry and lightly spray the wheel pivot pin with a dry silicon lubricant to keep the wheels moving smoothly. Please carefully read the lubricant instructions prior to use.
- Regularly spray all moving parts with a dry silicon lubricant. Please carefully read the lubricant instructions prior to use.
- Ensure all connecting rivets and screws are secure. Tighten if required.
- If there are compression marks on the tyres, use a domestic hair dryer to gently warm (DO NOT OVERHEAT) the tyre and the compression marks should slowly disappear.
- To maintain the safety and longevity of the stroller, seek prompt repairs or replacement for bent, torn, worn, or broken parts. Do not continue to use the stroller if unsafe.

- All repairs should only be carried out by an authorised Britax/Steelcraft repairer. Only Britax/Steelcraft replacement parts should be used with the stroller. It may be unsafe to use parts supplied from another manufacturer.

General Tips

Do not store the stroller in your car for prolonged periods of time during summer as it may lead to damage to some of the plastics components.

Do not leave the stroller in direct sunlight for extended periods of time, as colours of some fabrics may fade, and tyres may deteriorate.

Do not fold or store the stroller if damp or wet, as fabric may develop mould or mildew. Always store the stroller inside in a dry, well-ventilated area.

Do not place heavy objects on top of the stroller as it may alter the shape.

Should you have any further questions on care & maintenance of the stroller, please contact our Consumer Service Team at: aunz-support@britax.com

Care & Maintenance

Cleaning

Fabrics

- Removable fabrics may be cleaned using lukewarm water and soap or mild detergent. Rinse thoroughly and allow to dry away from direct sunlight.
- Non-removable fabrics can be spot cleaned using a damp sponge and soap or mild detergent. Allow to dry completely before re-use or storage.
- Never use bleach, or abrasive cleaning products.
- **DO NOT** iron or dry clean.

NOTE: DO NOT place any of the stroller fabrics in the dryer. Allow to dry naturally, away from direct sunlight.

Frame

- Remove dirt and dust away from any moving mechanism.
- Clean frame with a soft damp cloth and soap or mild detergent and allow to dry thoroughly.
- **DO NOT** use abrasive cleaning products as it may cause stains, discolouration or scratches to the frame.
- **DO NOT** soak or submerge frame in water.
- **DO NOT** remove, dismantle or alter any part of the stroller mechanism or brakes.

Leatherette

- Spot clean with a damp soft cloth.
- **DO NOT** use a dripping wet cloth or wet the leatherette excessively.

Wheels

- Remove wheels from stroller.
- Clean with damp cloth and soap or mild detergent. Use brush to remove dirt and mud build up around the tyre. Allow to dry thoroughly before placing wheels back on the frame.
- If necessary lubricate wheel shaft with a small amount of lubricant before placing into the stroller.
- Ensure the stroller is cleaned thoroughly after using it on the beach as sand and salt can damage stroller mechanism, wheel assembly, causing premature wear and corrosion.

PLEASE NOTE:

Our product warranty does not cover any rust to the rivets or screws, if you are caught in the rain or at the beach always thoroughly dry the frame to avoid any rust damage.

Care & Maintenance

Just like servicing your car or bicycle, prams and strollers also need **regular maintenance checks**. These checks can improve product performance, extend the life of your stroller and help to provide you and your children a safe and smooth journey.



We recommend servicing your stroller every 6 months and completing an inspection once a month. To prolong the life of your stroller, a regular maintenance should be performed.

5 STEP CHECK LIST

- 01 INSPECT SAFETY DEVICES** tether strap, frame lock, harness, buckle and brakes, and ensure all are in working order and free from dirt, sand, and debris.
- 02 INSPECT** all connecting rivets and screws are secure.
- 03 MAKE SURE FOLDING JOINTS** are free of dirt, dust, and debris by cleaning with a damp cloth, allow to dry and lightly spray with a dry silicon lubricant. Please carefully read the lubricant instructions prior to use.
- 04 REMOVE WHEELS** and wipe clean with a damp cloth to remove any dirt, sand or debris. Allow to dry and lightly spray the wheel pivot pin with a dry silicon lubricant to keep the wheels moving smoothly. Please carefully read the lubricant instructions prior to use.
- 05 ENSURE WHEN FOLDING AND STORING** to wipe down your stroller frame and allow to dry before storing in a dry place without direct sunlight.

Warranty

Did you know?

Registering your product online simplifies proof of purchase in the event of a warranty claim.

Head to our website to fill out the product registration form: britax.com.au
britax.co.nz



Making A Warranty Claim

Your rights under a **Britax** company warranty are separate from and independent of your rights under the statutory consumer guarantees. What you need to do to enforce your rights under a statutory consumer guarantee is set out in the **Australian Competition and Consumer Commission's Consumer Guarantees - A Guide for Consumers**.

To make a claim under a **Britax** company warranty, please contact our customer service team on:

Australia: 1300 303 330 / **New Zealand:** 0508 688 822 or alternatively by email at: aunz-support@britax.com

You will be required to :

- Return the product to the place of purchase or to a designated repair agent;
- Present your receipt as proof of purchase;
- Identify the defect in the product; and
- Present the product to **Britax** for inspection on request.

Britax will advise you whether the product is covered by the **Britax** company warranty. **Britax's** decision of whether a product is covered by a **Britax** company warranty is final. **Britax** will act reasonably when determining whether a product is covered by a company warranty.

Warranty

Australian Consumer Law

On all of our goods, you have the benefit of a statutory consumer guarantee. In summary, goods are guaranteed to be of “acceptable quality” (fit for purpose), goods are guaranteed to match any sample against which they are sold. These consumer guarantees are provided for by the Australian Consumer Law and, if you believe any one of these guarantees is not satisfied by a Britax product, you have rights under the Australian Consumer law to enforce that guarantee.

Your rights under the statutory consumer guarantees are set out in the **Australian Competition and Consumer Commission's Consumer Guarantees – A Guide for Consumers**.

In addition to the statutory consumer guarantees, **Britax** offers its own company warranty on all of its products. You therefore have the option of seeking redress for defective or faulty product either under the **Britax** company warranty or the statutory guarantees.

After the **Britax** company warranty expires, you still have your rights under the statutory consumer guarantees.

Depending on the product involved, the **Britax** company warranty on the following page applies:

Warranty

Steelcraft Warranty

Steelcraft products are covered by this company warranty against faulty materials and workmanship (normal wear and tear excluded) that affects the normal operation of your **Steelcraft** product. In the unlikely event that you find that your **Steelcraft** product does not satisfy this warranty, **Britax** will (at its option) repair or replace that product within a reasonable period of you making a claim in accordance with this policy.

In the event that a replacement product is no longer available, **Britax** reserves the right to provide what it considers to be a suitable alternative.

For this company warranty to apply, you must make an application before the expiration of the following periods from date of purchase*.



2 years on **Steelcraft** strollers and **Steelcraft** stroller accessories.*

This company warranty does not apply to second hand or after market goods or goods used for rental, hire or other commercial purposes or to any claim where the damage or fault is, in whole or part, the result of incorrect installation, mistreatment, intentional damage, any use other than use in normal conditions or any use otherwise than in accordance with the instruction manual for that product.

Please read your instruction manual carefully before using any of our products.

INTERNATIONAL WARRANTY

Britax products are available through a network of retailers in Australia and New Zealand. If you are an international customer we do not offer a warranty service outside of these regions.

THIS PRODUCT IS NOT INTENDED FOR COMMERCIAL USE



Britax Childcare Pty. Ltd.

A.B.N. 55 006 773 600

Level 4, 650 Lorimer Street, Port Melbourne, Victoria 3207, Australia

Phone: (03) 9288 7288 **Fax:** (03) 9311 5798

Customer Service

Australia: 1300 303 330 / **New Zealand:** 0508 688 822

Due to our continuing program of development, Britax reserves the right to alter the specifications, color or design without any further notice.

The **Steelcraft** trademark is the property of Britax Childcare Pty.Ltd - Australia.

The **Britax** trademark is the property of Britax Childcare Holdings Limited - UK.

Visit the **Britax** website at: **britax.com.au** or **britax.co.nz** or email us at **aunz-support@britax.com**

Due to the variations in the style and design of our products the illustrations used in this instruction booklet are generic.

This product is designed to comply with:

AS/NZS 8811.1:2013 "Methods of testing infant products. Method 1: Sleep surfaces – Test for firmness"

EN 1466:2014/AC:2015 "Safety requirements and test methods for child use and care articles – Carry cots and stands"

Australian Standard AS 2088:2022 "Prams and Strollers- Safety Requirements"

Copyright © 2021 Britax Childcare Pty. Ltd. Australia