

# strider<sup>V5</sup> second seat

signature

Compatible with **Strider Signature<sup>V5</sup>**  
and **Strider Signature strollers**.

*(All products are sold separately)*

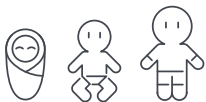

## 0 - 17kg

*(newborn - 3 years approx.)*

---

**IMPORTANT** KEEP THIS BOOKLET IN A SAFE  
PLACE FOR FUTURE REFERENCE

SERIES PC8343 | [britax.com.au](http://britax.com.au)  
[britax.co.nz](http://britax.co.nz)

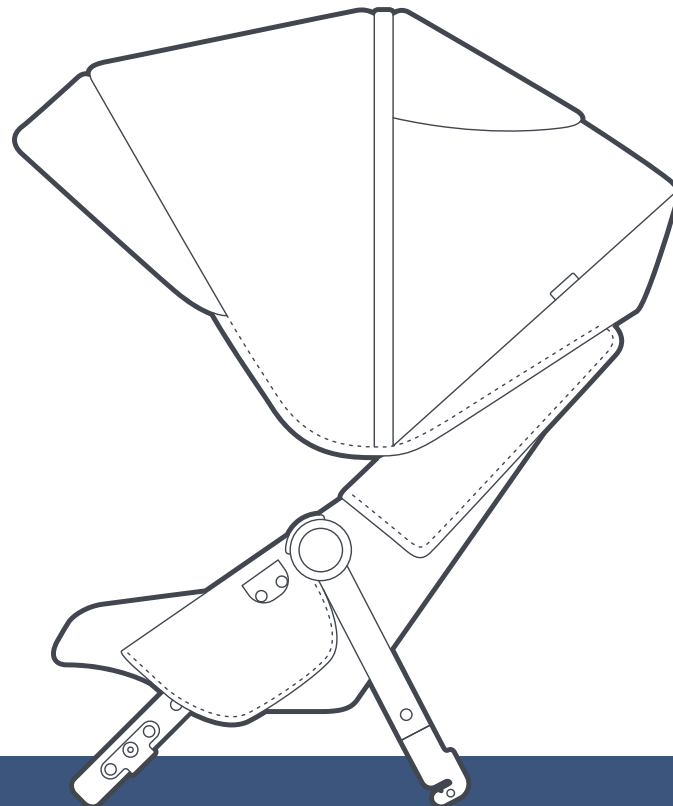

 **Steelcraft**

## Contents

Warnings & Important Notes	03	Adjusting the Shoulder Harness Height	16
Lift & Carry Correctly	04	Folding the Stroller	16
What's in the Box	05	Folding the Stroller with the Second Seat	17
Compatibility	05	Attaching the Second Seat Extension Adaptors	18
Second Seat Features	06	Removing the Second Seat Extension Adaptors	18
<b>Second Seat Assembly</b>		Attaching the Second Seat to the Stroller Frame Using the Extension Adaptors	19
Attaching the Canopy	07	Attaching Baby Capsule to Second Seat Frame	20
Attaching the Wheel Guards	08	Removing Baby Capsule from Second Seat Frame	21
Attaching the Shoulder Pads	08	Attaching the fabric Cover to the Second Seat Frame	21
Setting the Basket to Tandem Mode	09	<b>Care &amp; Maintenance</b>	22
<b>Second Seat Operation</b>		<b>Warranty</b>	25
Attaching the Second Seat to the Stroller Frame	10		
Adjusting the Backrest	12		
Removing the Second Seat from the Stroller Frame	13		
Securing Your Child Harness	14		
Adjusting the Harness	15		
Opening the Harness	15		

## Warnings & Important Notes

### **WARNINGS**

- **SECURE THE CHILD IN THE HARNESS AT ALL TIMES.**
- **DO NOT USE ANY ACCESSORIES OTHER THAN THOSE APPROVED FOR USE WITH THIS STROLLER BY BRITAX.**
- **IT IS UNSAFE TO USE ACCESSORIES NOT APPROVED FOR USE WITH THIS STROLLER.**
- **THE MAXIMUM WEIGHT OF THE CHILD USING THIS SECOND SEAT IS NOT TO EXCEED 17KG.**

**FOR IMPORTANT NOTES AND WARNINGS ON ACCESSORIES** - REFER TO THEIR INDIVIDUAL SECTIONS IN THIS BOOK OR THE INSTRUCTION MANUAL INCLUDED WITH THE INDIVIDUAL PRODUCTS. THE MAXIMUM WEIGHT VARIES FOR EACH ACCESSORY.

### **IMPORTANT NOTES:**

- **Do not use this second seat with any other models of stroller.**
- **The Strider Signature Second Seat is designed to fit Strider Signature strollers.**
- **The second seat must be correctly fitted and locked onto the stroller frame.**
- **The second seat can only be used in the forward facing position, connected to the rear of the stroller.**
- **Do not overload the stroller. Overloading will cause stroller to tip backwards.**



This **CAUTION** symbol is shown at certain steps in this instruction manual to highlight the danger of being injured by moving parts.

## Lift & Carry Correctly

**The SMART lifting technique:** This technique can be used to pick up small light loads from low levels.

### Size up the load

- Assess the load (size, shape, and weight).
- Assess whether the load needs to be moved;
- Where is it going to be placed? Check that there are no obstructions;
- Assess whether mechanical or human assistance is required.

### Move the load as close to the body as possible

- A load is heavier to lift or carry if it is not close to the body.
- The whole hand should be used to ensure a firm grip.

### Always bend your knees

- Maintain balance.
- Keep feet apart and in a comfortable position.
- Minimise lower back bending.
- Bend knees preferable at as large an angle as possible but not at a right angle - use a semi-squat in preference to a full squat.

### Raise the load with your legs

- Achieve the lift smoothly and without jerkiness.
- Maintain the normal curvature of the spine to allow the force of the load to be distributed evenly from the spine to the pelvis.

### Turn your feet in the direction that you want to move the load.

- Avoid unnecessary bending, twisting, and reaching.
- Change direction by turning your feet and not your back.
- To set the load down, squat down, keep your head up and let your legs do the work.

Remember to **THINK TALL** - chest lifted, shoulders relaxed, chin tucked in, and head level.

## What's in the Box

1 x Second Seat



2 x Shoulder Harness Pads



2 x Wheel Guards

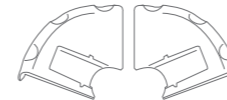

1 x Set of Seat Extenders/Adaptors



## Compatible with:

- Strider Signature<sup>V5</sup> strollers
- Strider Signature strollers

## Second Seat Features

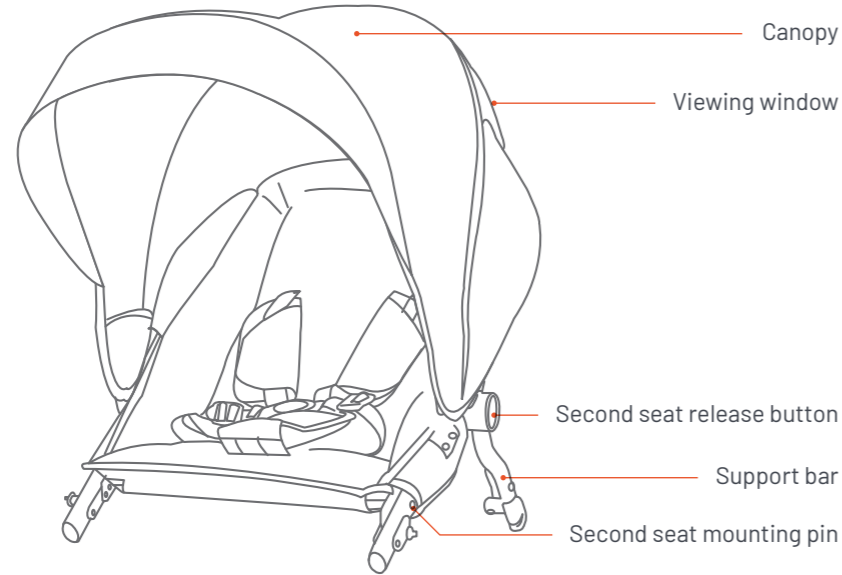

## Second Seat Assembly

### Attaching the Canopy

**IMPORTANT NOTE:** The sun is very strong. **DO NOT LEAVE YOUR CHILD EXPOSED TO THE SUN.** The canopy or hood on this product will not give your child total protection from the harmful rays of the sun.

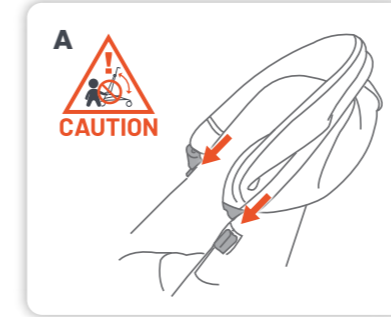

**A** Fit the canopy over the back of seat and slide the canopy mouldings onto the canopy frame mouldings until they interlock together.

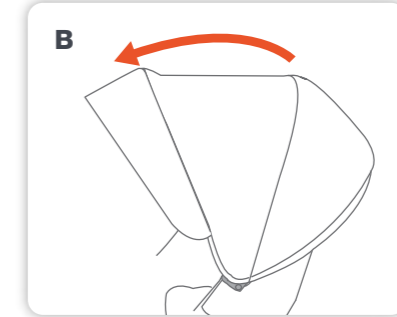

**B** To adjust the canopy, open by pulling forward, or close by pushing the canopy backward.

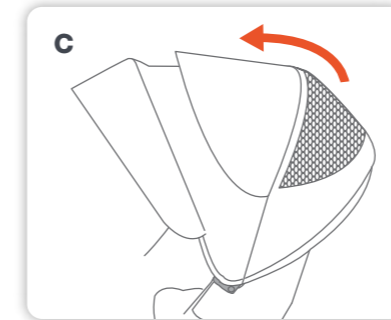

**C** To expose mesh window, open the window flap to the back.

## Second Seat Assembly

### Attaching the Wheel Guards

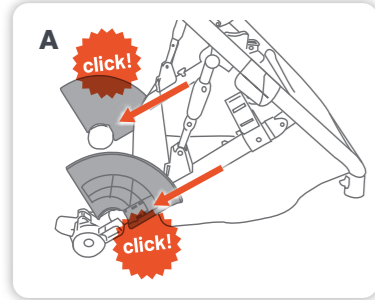

**A** Slide each guard onto the mounting bracket above each rear wheel housing and push down until it locks into place. There is left and right wheel guard. Please ensure it is locked.

### Attaching the Shoulder Pads

#### IMPORTANT NOTE:

Ensure that the shoulder straps are fitted through the appropriate harness slots to suit your child's seated shoulder height.

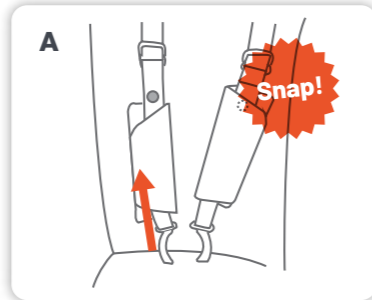

**A** Slide the shoulder pads through the shoulder harness and close the stud on the shoulder harness with one in the shoulder pads to keep the shoulder pads in place.

## Second Seat Assembly

### Removing the Basket Extension

Note: In order to install the second seat, the basket extension must be removed first. Refer to basket grey area on image A below.

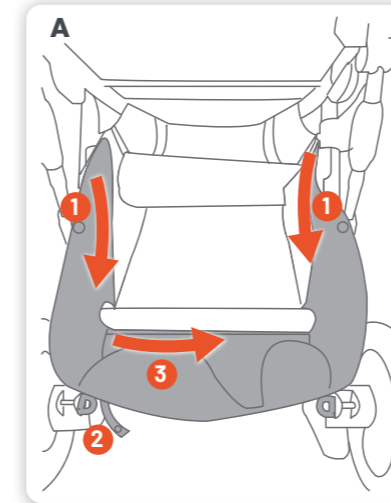

**A** Remove the basket back extension by:

- (1) Undo press studs on both sides of the frame.
- (2) Unfasten the straps at the bottom of the basket near the back wheel housing.
- (3) Unzip the basket from underneath under the basket cross bar.

KEEP THE BASKET EXTENSION IN A SAFE PLACE FOR FUTURE USE.

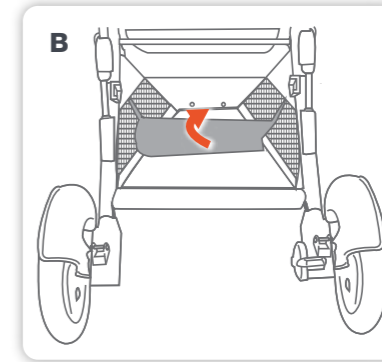

**B** Ensure the basket divider located in the base of the basket is up to separate the child's feet to the contents of the rest of the basket.

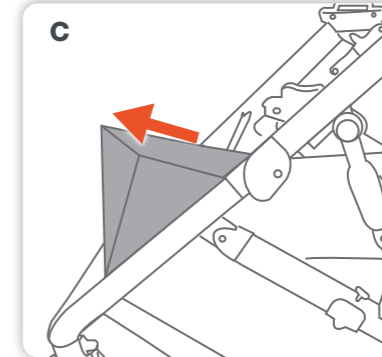

**C** The front of the basket can be extended by pulling out to allow for additional storage and easy access to the basket.

**TIP:** When a child is in the second seat, it is recommended to access the storage basket from the front.

## Second Seat Operation

### Attaching the Second Seat to the Stroller Frame

#### IMPORTANT NOTES:

PLEASE REFER TO PAGE 4 FOR SMART LIFTING TECHNIQUES.

- When opening the stroller, be aware of the danger of being injured by moving parts and locking devices during the process. Keep all hands and limbs clear of these parts.
- There is potential for fingers or parts of the body to be injured when the stroller is being unfolded, due care should be exercised.
- Keep children clear of the stroller when unfolding the stroller.

**TIP:** Extension Adaptors can be used to create more space between the stroller seat and second seat. (Refer to page 18)

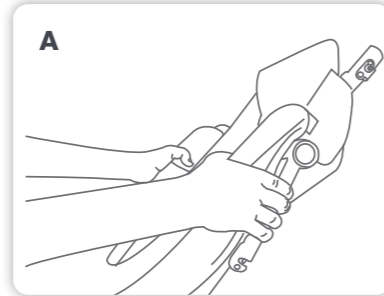

**A** For attaching the second seat to the stroller frame, fold the support bars to the back of the second seat and hold with hands.

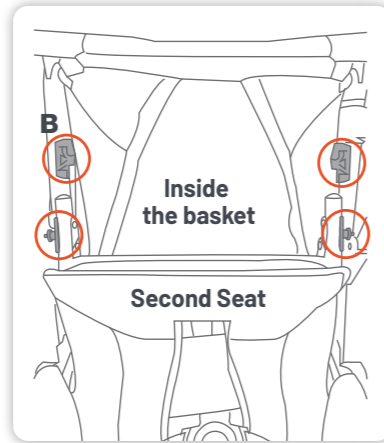

**B** Line up the second seat mounting pins with the mounting brackets on the stroller frame. Line up the support bars on the second seat with the lower mounting brackets on the inside of the stroller frame (located on rear wheel housing).

## Second Seat Operation

### Attaching Second Seat to the Stroller Frame

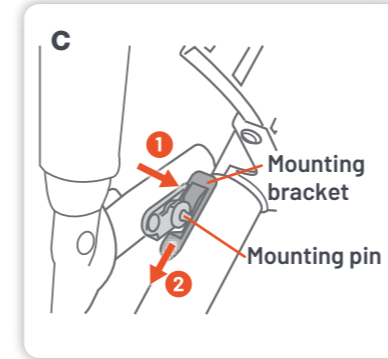

**C** Slide the mounting pins into the mounting brackets (as indicated by arrow 1) on the stroller frame then pull downwards (as indicated by arrow 2).

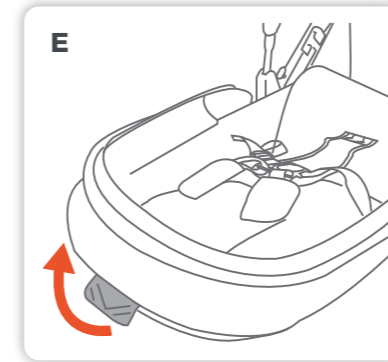

**E** Lift the recline lever of the second seat so the foot end slides completely down and engages into the stroller frame. Pull the second seat upwards to ensure it is locked onto the stroller frame.

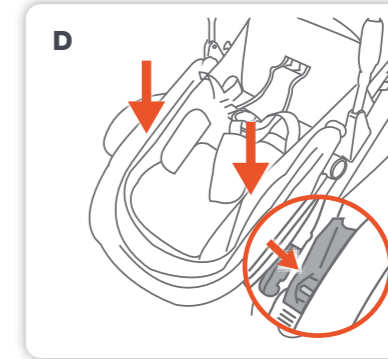

**D** Lower the second seat and press down until the support bars are locked into the lower mounting brackets on the inside of the stroller frame (located on rear wheel housing).

## Second Seat Operation

### Adjusting the Backrest

#### **WARNINGS:**

- THE UPRIGHT POSITIONS ARE NOT SUITABLE FOR USE WITH CHILDREN LESS THAN 6 MONTHS OLD.
- THE LOWEST RECLINE POSITION SHOULD BE USED TO TRANSPORT BABIES. THE BACKREST CAN BE ADJUSTED TO A MORE UPRIGHT POSITION AS THE CHILD GROWS OLDER AND IS ABLE TO SUPPORT ITS HEAD WITHOUT ASSISTANCE.

 **TIP:** If the child is sitting in the seat, support the backrest as it reclines. If you have difficulty adjusting the backrest you may need to remove the child from the seat to allow you to raise or lower the backrest with ease.

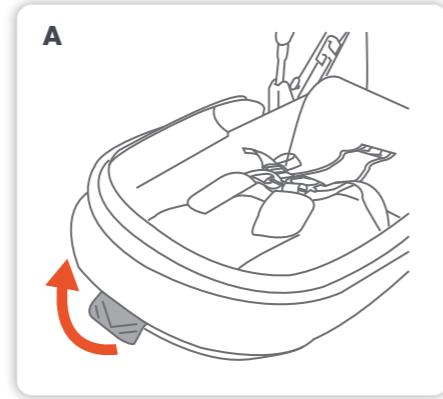

**A** Lift the recline lever on the back of the seat and hold while raising or lowering the backrest to the desired position.

## Second Seat Operation

### Removing the Second Seat From the Stroller Frame

**IMPORTANT NOTE:** Always remove your child from the second seat before folding or removing it.

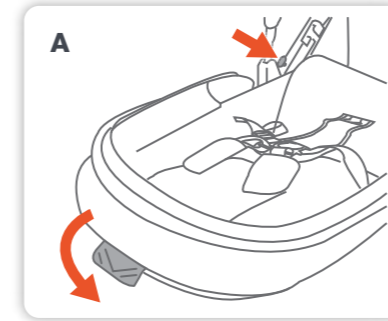

**A** Fold the canopy back, then fully lift the recline lever and lower the second seat to the lowest position. While still holding the recline lever, press the second seat safety release button and continue to lower the seat.

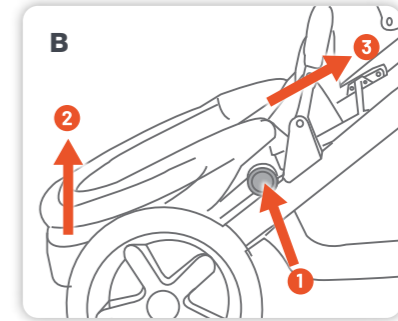

**B** Grasp the sides of the second seat frame and press the second seat release buttons in on both sides of the second seat. While holding the button, lift the seat up and forward to release the seat.

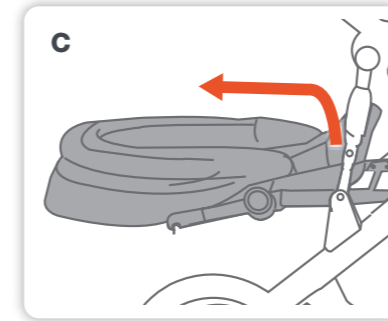

**C** Lift the second seat up and away from the stroller frame.

## Second Seat Operation

### Securing Your Child Harness

#### **WARNINGS:**

- **USE THE HARNESS AT ALL TIMES.**
- **ENSURE YOUR CHILD IS SECURED WITH A CORRECTLY ADJUSTED HARNESS.**
- **THE ADJUSTED HARNESS SHOULD CLOSELY FIT THE CHILD.**
- **NEVER LEAVE THE HARNESS BUCKLED WHEN NOT FITTED TO A CHILD IN THE STROLLER, BECAUSE THE HARNESS CAN FORM LOOPS WHICH MAY POSE A STRANGULATION HAZARD.**
- **WHEN HARNESS IS NOT IN USE, DISCONNECT SHOULDER STRAPS FROM THE WAIST STRAPS AND BUCKLE TO PREVENT STRANGULATION.**
- A five-point harness is provided to restrain your child.
- Buckle tongues separate for added safety.
- To reconnect buckle tongues and to secure the child in the harness please follow the steps to the right carefully.

**PLEASE NOTE:** Each waist buckle tongue has a raised rib on one side and can only be locked into the buckle assembly with the raised rib facing up. Ensure the harness straps are not twisted as they may become uncomfortable for the child.

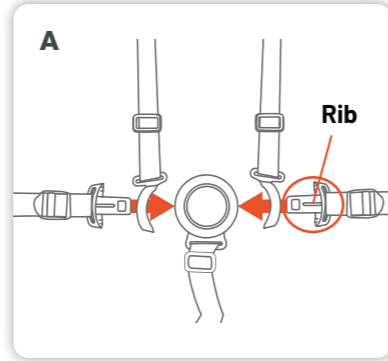

**A** Always apply the brakes before placing child in the stroller seat. Position the shoulder strap near the child's shoulder and position crotch strap between legs. Thread the waist strap buckle tongues through the shoulder straps tongue guides.

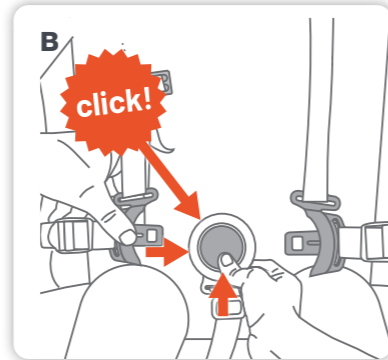

**B** Hold the centre button in on the crotch buckle and insert the waist buckle tongues into the crotch strap buckle until you hear a 'click'. Repeat the procedure on the other side. Please ensure it is locked.

## Stroller Operation

### Adjusting the Harness

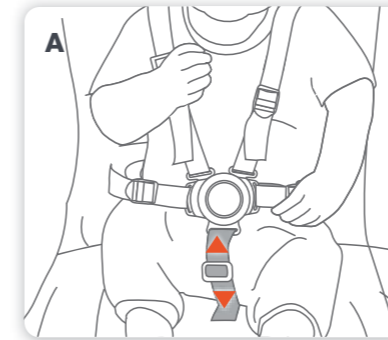

**A** Tighten or loosen the crotch strap by sliding the harness adjuster up or down to the desired fit. Note: The crotch strap should be adjusted to a snug fit.

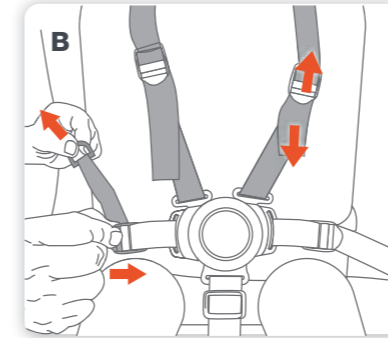

**B** Tighten or loosen the waist and shoulder straps by sliding the harness adjuster to the desired fit. Note: The straps need to fit firmly around the child.

### Opening the Harness

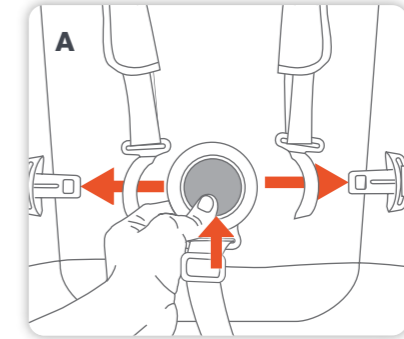

**A** To release the harness, press in the centre of the buckle to release all straps at once.



## Stroller Operation

### Adjusting the Shoulder Harness Height

**IMPORTANT NOTE:** The harness can be adjusted to different heights to accommodate the child. The shoulder straps must be positioned near the child's shoulders.

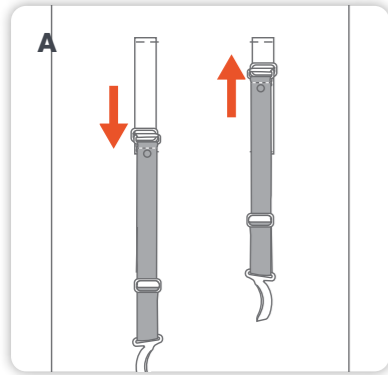

**A** To change the shoulder harness height, simply hold the shoulder harness and slide up and down to desired position.

## Second Seat Operation

### Folding the Stroller

#### IMPORTANT NOTES:

PLEASE REFER TO PAGE 3 FOR SMART LIFTING TECHNIQUES.

- Remove the child from the second seat before commencing a folding operation.
- Fold the second seat slowly and be careful where you place your hands.
- When folding the second seat be aware of the danger of being injured by moving parts and locking devices during the process.
- Keep all hands and limbs clear of these parts.
- There is potential for fingers or parts of the body to be injured when the second seat is being folded, due care to be exercised.
- Keep children clear of the stroller during folding of the stroller.
- Fold the second seat before folding the stroller.
- Incorrect folding may cause damage to the stroller and frame.
- Please follow the folding instructions carefully.

## Second Seat Operation

### Folding the Stroller with the Second Seat

#### IMPORTANT NOTE:

- Remove the child from the stroller.
- Engage the brakes.
- Ensure the front wheels are in swivel mode so the front wheels will automatically position under the stroller during folding.
- Close the canopy.
- When you are folding the stroller with the second seat, make sure the handle height is set to the highest position aligned with the frame to prevent the handle coming in contact with the second seat and causing damage to the stroller (see **B**).

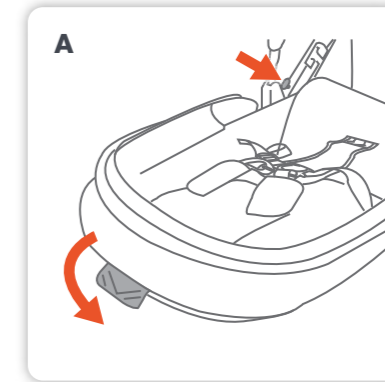

**A** Fully lift the recline lever and lower the second seat to the lowest position. While still holding the recline lever, press the second seat safety release button and continue to lower the seat.

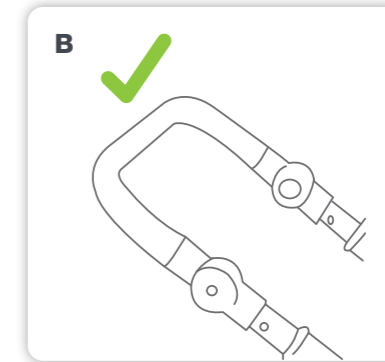

**B** Handle height aligned with frame

## Second Seat Operation

### Attaching the Seat Extenders/Adaptors

NOTE: The seat extenders/adaptors are for tandem mode use, they create more space between the top and second seat.

Please adjust seats to desired configuration. Do not use the configuration if there isn't enough space for lower occupant. Refer to stroller configuration page on stroller instruction manual.

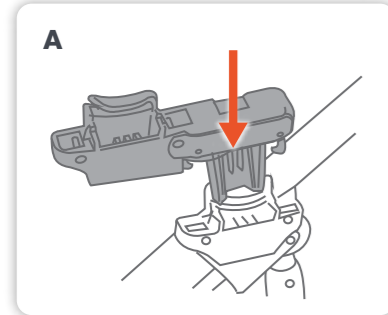

**A** Attach the seat extenders/adaptors to the stroller frame by lining up the connectors with the stroller frame sockets, the extenders/adaptors should extend towards the stroller front wheels.



**B** Press down on the adaptors until they lock into the frame sockets.

### Removing the Included Second Seat Extension Adaptors

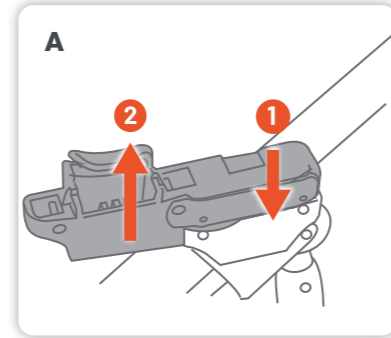

**A** To remove the adaptors, press in and hold the button, then pull the adaptor up and out of the frame sockets.

## Second Seat Operation

### Attaching the Second Seat to the Stroller Frame Using the Extension Adaptors

**CAUTION:** Stroller seat, bassinet or baby capsule must be correctly attached.

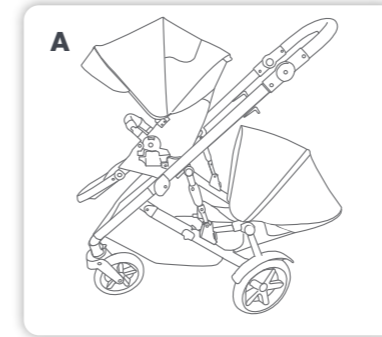

**A** The stroller seat attaches and locks the same way with adaptors as instructed in stroller instruction manual without adaptors. The stroller seat can be adjusted with all 4 positions when facing forward.

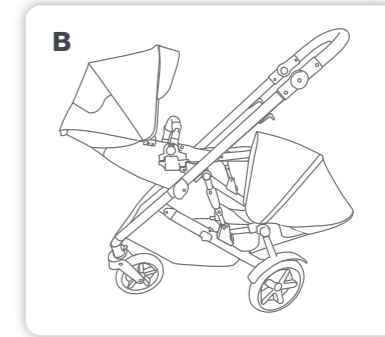

**B** When the stroller top seat is facing rearward (facing handle), the most reclined position is the only available position when using the adaptors.

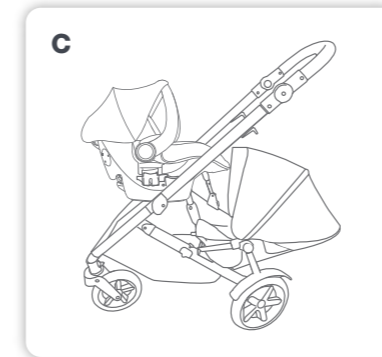

**C** For the correct attachment for baby capsules, please refer to baby capsule instruction book.



**D** For the correct attachment for the bassinet, please refer to bassinet instruction book. The bassinet is recommended to use with the second seat in the most reclined position.

## Second Seat Operation

### Attaching the Britax Unity Baby Capsule to the Second Seat Frame

NOTE: To attach the baby capsule to the lower seat position Click & Go™ adaptors are required. The second seat frame has Click & Go™ adaptors built into the frame. To use, simply remove second seat fabric cover from the frame to expose the adaptors.

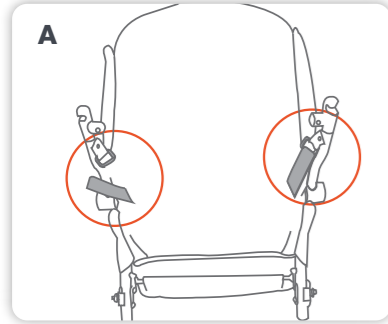

**A** Remove the second seat canopy and all fabrics from the frame. Slide the webbing out of the D-rings.

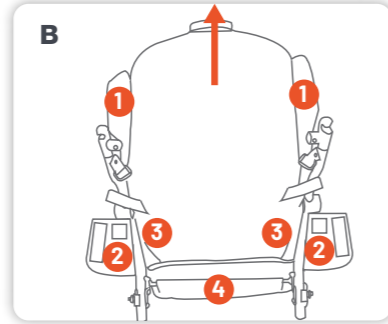

**B** Unfasten all the hook and loop strips as indicated. And then pull the fabric cover over the frame.

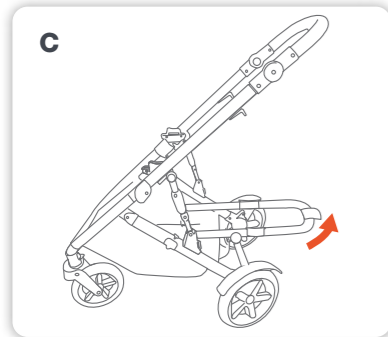

**C** Attach the second seat to the stroller frame, refer to page 10. Lift the frame to the horizontal level when the second lock is engaged.

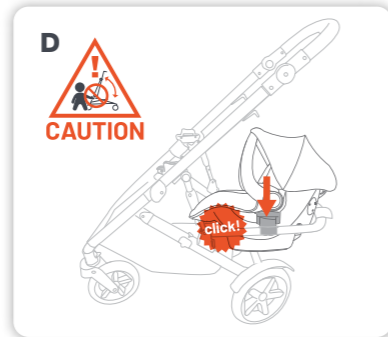

**D** The Britax Unity Baby Capsule must be on world facing mode (towards the stroller front wheels). Lower the baby capsule into the second seat frame sockets until the baby capsule is locked.

## Second Seat Operation

### Removing the Baby Capsule from the Second Seat Frame

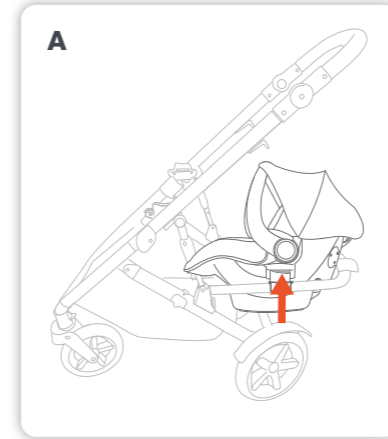

**A** Before removing the Britax Unity Baby Capsule, lock the stroller brake first. Squeeze both release levers on the Click & Go connectors at the same time and support the weight of the Britax Unity Baby Capsule. Lift and remove the baby capsule from the second seat frame sockets.

## Second Seat Operation

### Attaching the Fabric Cover to the Second Seat Frame

**IMPORTANT NOTE:** To attach the baby capsule to the second seat frame, the fabric cover must be removed.

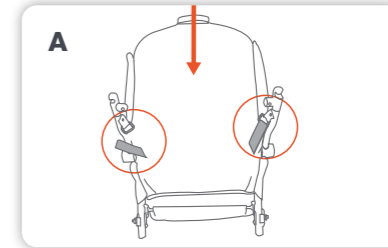

**A** Pull the cover over the frame. Pull the webbing through the button holes and connect with D-rings.

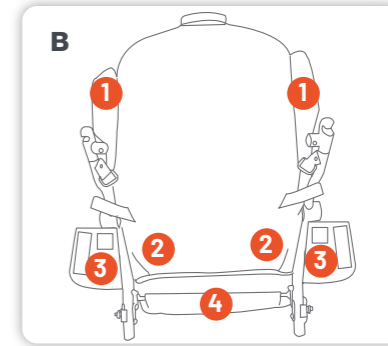

**B** Fasten all the hook and loop strips as indicated. Attach the canopy. (Refer to page 6)

## Care & Maintenance

### General Maintenance & Repair

- Ensure all safety devices, locks, harness, and brakes are in working order.
- Ensure all joints and folding areas move freely as intended.
- Should any moving or locking parts become stiff or hard to operate, ensure these are free from tension, or dirt by wiping clean with a damp cloth to remove any dirt, sand, or debris. Allow to dry and lightly spray with a dry silicon lubricant. Please carefully read the lubricant instructions prior to use.
- Ensure wheels are regularly cleaned with a damp cloth by removing dirt, sand, or debris. Allow to dry and lightly spray the wheel pivot pin with a dry silicon lubricant to keep the wheels moving smoothly. Please carefully read the lubricant instructions prior to use.
- Regularly spray all moving parts with a dry silicon lubricant. Please carefully read the lubricant instructions prior to use.
- Ensure all connecting rivets and screws are secure. Tighten if required.
- If there are compression marks on the tyres, use a domestic hair dryer to gently warm (DO NOT OVERHEAT) the tyre and the compression marks should slowly disappear.
- To maintain the safety and longevity of the stroller, seek prompt repairs or replacement for bent, torn, worn, or broken parts. Do not continue to use the stroller if unsafe.

- All repairs should only be carried out by an authorised Britax/Steelcraft repairer. Only Britax/Steelcraft replacement parts should be used with the stroller. It may be unsafe to use parts supplied from another manufacturer.

#### General Tips

**Do not store the stroller in your car** for prolonged periods of time during summer as it may lead to damage to some of the plastics components.

**Do not leave the stroller in direct sunlight** for extended periods of time, as colours of some fabrics may fade, and tyres may deteriorate.

**Do not fold or store the stroller if damp or wet**, as fabric may develop mould or mildew. Always store the stroller inside in a dry, well-ventilated area.

**Do not place heavy objects on top of the stroller** as it may alter the shape.

Should you have any further questions on care & maintenance of the stroller, please contact our Consumer Service Team at: [aunz-support@britax.com](mailto:aunz-support@britax.com)

## Care & Maintenance

### Cleaning

#### Fabrics

- Removable fabrics may be cleaned using lukewarm water and soap or mild detergent. Rinse thoroughly and allow to dry away from direct sunlight.
- Non-removable fabrics can be spot cleaned using a damp sponge and soap or mild detergent. Allow to dry completely before re-use or storage.
- Never use bleach, or abrasive cleaning products.
- **DO NOT** iron or dry clean.

**NOTE: DO NOT** place any of the stroller fabrics in the dryer. Allow to dry naturally, away from direct sunlight.

#### Frame

- Remove dirt and dust away from any moving mechanism.
- Clean frame with a soft damp cloth and soap or mild detergent and allow to dry thoroughly.
- **DO NOT** use abrasive cleaning products as it may cause stains, discolouration or scratches to the frame.
- **DO NOT** soak or submerge frame in water.
- **DO NOT** remove, dismantle or alter any part of the stroller mechanism or brakes.

#### Leatherette

- Spot clean with a damp soft cloth.
- **DO NOT** use a dripping wet cloth or wet the leatherette excessively.

#### Wheels

- Remove wheels from stroller.
- Clean with damp cloth and soap or mild detergent. Use brush to remove dirt and mud build up around the tyre. Allow to dry thoroughly before placing wheels back on the frame.
- If necessary lubricate wheel shaft with a small amount of lubricant before placing into the stroller.
- Ensure the stroller is cleaned thoroughly after using it on the beach as sand and salt can damage stroller mechanism, wheel assembly, causing premature wear and corrosion.

#### PLEASE NOTE:

Our product warranty does not cover any rust to the rivets or screws, if you are caught in the rain or at the beach always thoroughly dry the frame to avoid any rust damage.

## Care & Maintenance

Just like servicing your car or bicycle, prams and strollers also need **regular maintenance checks**. These checks can improve product performance, extend the life of your stroller and help to provide you and your children a safe and smooth journey.



We recommend servicing your stroller every 6 months and completing an inspection once a month. To prolong the life of your stroller, a regular maintenance should be performed.

### 5 STEP CHECK LIST

- 01 INSPECT SAFETY DEVICES** tether strap, frame lock, harness, buckle and brakes, and ensure all are in working order and free from dirt, sand, and debris.
- 02 INSPECT** all connecting rivets and screws are secure.
- 03 MAKE SURE FOLDING JOINTS** are free of dirt, dust, and debris by cleaning with a damp cloth, allow to dry and lightly spray with a dry silicon lubricant. Please carefully read the lubricant instructions prior to use.
- 04 REMOVE WHEELS** and wipe clean with a damp cloth to remove any dirt, sand or debris. Allow to dry and lightly spray the wheel pivot pin with a dry silicon lubricant to keep the wheels moving smoothly. Please carefully read the lubricant instructions prior to use.
- 05 ENSURE WHEN FOLDING AND STORING** to wipe down your stroller frame and allow to dry before storing in a dry place without direct sunlight.

## Warranty

### Did you know?

Registering your product online simplifies proof of purchase in the event of a warranty claim.

Head to our website to fill out the product registration form: [britax.com.au](http://britax.com.au)  
[britax.co.nz](http://britax.co.nz)



### Making A Warranty Claim

Your rights under a **Britax** company warranty are separate from and independent of your rights under the statutory consumer guarantees. What you need to do to enforce your rights under a statutory consumer guarantee is set out in the **Australian Competition and Consumer Commission's Consumer Guarantees - A Guide for Consumers**.

To make a claim under a **Britax** company warranty, please contact our customer service team on:

**Australia:** 1300 303 330 / **New Zealand:** 0508 688 822 or alternatively by email at: [aunz-support@britax.com](mailto:aunz-support@britax.com)

You will be required to :

- Return the product to the place of purchase or to a designated repair agent;
- Present your receipt as proof of purchase;
- Identify the defect in the product; and
- Present the product to **Britax** for inspection on request.

**Britax** will advise you whether the product is covered by the **Britax** company warranty. **Britax's** decision of whether a product is covered by a **Britax** company warranty is final. **Britax** will act reasonably when determining whether a product is covered by a company warranty.

## Warranty

### Australian Consumer Law

On all of our goods, you have the benefit of a statutory consumer guarantee. In summary, goods are guaranteed to be of “acceptable quality” (fit for purpose), goods are guaranteed to match any sample against which they are sold. These consumer guarantees are provided for by the Australian Consumer Law and, if you believe any one of these guarantees is not satisfied by a Britax product, you have rights under the Australian Consumer law to enforce that guarantee.

Your rights under the statutory consumer guarantees are set out in the **Australian Competition and Consumer Commission's Consumer Guarantees - A Guide for Consumers**.

In addition to the statutory consumer guarantees, **Britax** offers its own company warranty on all of its products. You therefore have the option of seeking redress for defective or faulty product either under the **Britax** company warranty or the statutory guarantees.

After the **Britax** company warranty expires, you still have your rights under the statutory consumer guarantees.

Depending on the product involved, the **Britax** company warranty on the following page applies:

## Warranty

### Steelcraft Warranty

**Steelcraft** products are covered by this company warranty against faulty materials and workmanship (normal wear and tear excluded) that affects the normal operation of your **Steelcraft** product. In the unlikely event that you find that your **Steelcraft** product does not satisfy this warranty, **Britax** will (at its option) repair or replace that product within a reasonable period of you making a claim in accordance with this policy.

In the event that a replacement product is no longer available, **Britax** reserves the right to provide what it considers to be a suitable alternative.

For this company warranty to apply, you must make an application before the expiration of the following periods from date of purchase\*.



2 years on **Steelcraft** strollers and **Steelcraft** stroller accessories.\*

This company warranty does not apply to second hand or after market goods or goods used for rental, hire or other commercial purposes or to any claim where the damage or fault is, in whole or part, the result of incorrect installation, mistreatment, intentional damage, any use other than use in normal conditions or any use otherwise than in accordance with the instruction manual for that product.

Please read your instruction manual carefully before using any of our products.

### INTERNATIONAL WARRANTY

**Britax** products are available through a network of retailers in Australia and New Zealand. If you are an international customer we do not offer a warranty service outside of these regions.

**THIS PRODUCT IS NOT INTENDED FOR COMMERCIAL USE**



Art No. 4002304\_B

## **Britax Childcare Pty. Ltd.**

A.B.N. 55 006 773 600

Level 4, 650 Lorimer Street, Port Melbourne, Victoria 3207, Australia

**Phone:** (03) 9288 7288 **Fax:** (03) 9311 5798

## **Customer Service**

**Australia:** 1300 303 330 / **New Zealand:** 0508 688 822

Due to our continuing program of development, Britax reserves the right to alter the specifications, color or design without any further notice.

The **Steelcraft** trademark is the property of Britax Childcare Pty.Ltd - Australia.

The **Britax** trademark is the property of Britax Childcare Holdings Limited - UK.

Visit the **Britax** website at: **britax.com.au** or **britax.co.nz** or email us at **aunz-support@britax.com**

Due to the variations in the style and design of our products the illustrations used in this instruction booklet are generic.

This product is designed to comply with **Australian and New Zealand standard AS/NZS 2088:2013** "Prams and Strollers- Safety Requirements"

Copyright © 2021 Britax Childcare Pty. Ltd. Australia