

# strider<sup>V5</sup>

signature

## Tandem Travel System



**0 - 20kg**

(newborn - 4 years approx.)

**IMPORTANT** KEEP THIS BOOKLET IN A SAFE PLACE FOR FUTURE REFERENCE

SERIES HA8346 | [britax.com.au](http://britax.com.au)  
[britax.co.nz](http://britax.co.nz)

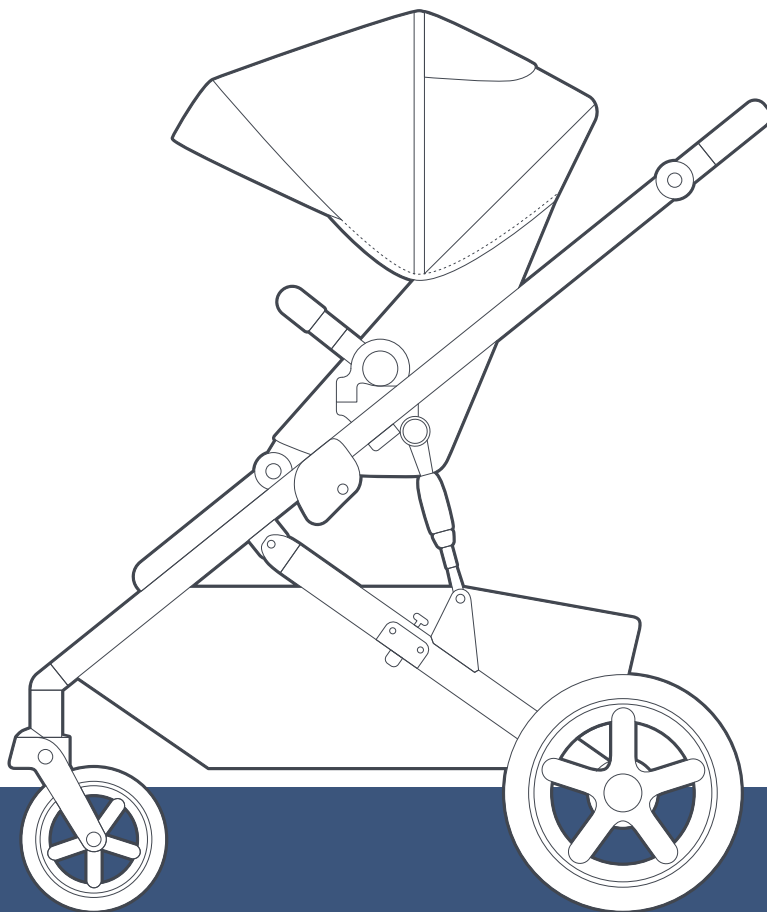

 **Steelcraft**

# Contents

## Stroller Section

Stroller Warnings and Important Notes	04
Lift & Carry Correctly	06
What's in the Box: Parts	07
What's in the Box: Included Accessories	08
Optional Accessories & Compatibility	08
Stroller Features	09
Stroller Configurations	11

## Stroller Assembly

Opening the Stroller Frame	12
Attaching or Removing the Rear Wheels	13
Attaching or Removing the Front Wheels	13
Attaching the Stroller Seat	14
Attaching the Canopy	15
Attaching the Arm Bar	16
Attaching the Organiser Bag	17
Installing the Newborn Comfort Insert	18
Attaching the Cup / Bottle holder	20
Installing the Sun Shade	20
Installing the Rain Cover	21

## Stroller Operation

Using the Brakes	22
Using the Front Wheel Swivel Lock	22
Adjusting the Backrest	23
Adjusting the Leg Rest	24
Adjusting the Pivotal Handle	24
Securing Your Child in the Harness	25
Adjusting the Harness	26
Opening the Harness	26
Adjusting the Shoulder Harness Height	27
Using the Storage Basket	27
Using the Tether Strap	28
Removing and Reversing the Stroller Seat	29

## Stroller Operation

Using the Stroller	30
Folding the Stroller	31
Lifting and Carrying the Stroller	33
Installing and Removing the Click & Go™ Adaptors	34

## Bassinet

Bassinet Warnings & Important Notes	35
Attaching & Removing Click & Go™ Signature Bassinet	36
Attaching / Removing Strider Bassinet	37

## Second Seat

Second Seat Warnings & Important Notes	38
Removing the Back Extension of the Basket	39
Attaching the Second Seat to the Stroller Frame	40
Removing the Second Seat from the Stroller Frame	41

## Baby Capsule

Baby Capsule Warnings & Important Notes	43
Attaching & Removing the Unity Baby Capsule	44

## Care & Maintenance

## Warranty

**Always** follow the manufacturer's instructions. Read all instructions carefully before assembly and use of this stroller.

**The correct use and maintenance of this product is essential.**

## **WARNINGS TO AVOID INJURY OR DEATH:**

- DO NOT LEAVE CHILDREN UNATTENDED.
- SECURE THE CHILD IN THE HARNESS AT ALL TIMES.
- DO NOT CARRY EXTRA CHILDREN OR BAGS ON THIS STROLLER.
- MAKE SURE CHILDREN ARE CLEAR OF ANY MOVING PARTS IF YOU ADJUST THE STROLLER, OTHERWISE THEY MAY BE INJURED.
- DO NOT USE ANY ACCESSORIES OTHER THAN THOSE APPROVED FOR USE WITH THIS STROLLER BY BRITAX.
- IT IS UNSAFE TO USE ACCESSORIES NOT APPROVED FOR USE WITH THIS STROLLER.
- THE MAXIMUM WEIGHT OF THE CHILD IS NOT TO EXCEED:  
STROLLER: 20KG  
CLICK & GO™ BASSINET: 9KG  
SECOND SEAT: 17KG

**FOR IMPORTANT NOTES AND WARNINGS ON ACCESSORIES**  
- REFER TO THEIR INDIVIDUAL SECTIONS IN THIS BOOK OR THE INSTRUCTION MANUAL INCLUDED WITH THE INDIVIDUAL PRODUCTS. THE MAXIMUM WEIGHT VARIES FOR EACH ACCESSORY.

## **IMPORTANT NOTES:**

- Use great care when using the stroller on travelators or other moving surfaces.
- Do not use the stroller on stairs, escalators.
- Do not lift the stroller by the arm bar (supplied) because it may disengage.
- Do not allow children to stand on the seat.
- Do not hang bags unless they are supplied or goods from the handle as this could cause the stroller to tip over.
- Do not leave the stroller and its accessories near an open fire or exposed flame.
- Do not place more than 12kg in the basket at single-mode or 4kg at double-mode, or 1kg in the seat pocket (if supplied), 1kg in the bassinet pocket (if supplied), 1kg in the cup/bottle holder or 1.5kg in the organiser bag (if supplied).



**CAUTION**

This **CAUTION** symbol is shown at certain steps in this instruction manual to highlight the danger of being injured by moving parts.

## Lift & Carry Correctly

**The SMART lifting technique:** This technique can be used to pick up small light loads from low levels.

### Size up the load

- Assess the load (size, shape, and weight).
- Assess whether the load needs to be moved;
- Where is it going to be placed? Check that there are no obstructions;
- Assess whether mechanical or human assistance is required.

### Move the load as close to the body as possible

- A load is heavier to lift or carry if it is not close to the body.
- The whole hand should be used to ensure a firm grip.

### Always bend your knees

- Maintain balance.
- Keep feet apart and in a comfortable position.
- Minimise lower back bending.
- Bend knees preferable at as large an angle as possible but not at a right angle - use a semi-squat in preference to a full squat.

### Raise the load with your legs

- Achieve the lift smoothly and without jerkiness.
- Maintain the normal curvature of the spine to allow the force of the load to be distributed evenly from the spine to the pelvis.

### Turn your feet in the direction that you want to move the load.

- Avoid unnecessary bending, twisting, and reaching.
- Change direction by turning your feet and not your back.
- To set the load down, squat down, keep your head up and let your legs do the work.

Remember to **THINK TALL** - chest lifted, shoulders relaxed, chin tucked in, and head level.

## What's in the Box: Parts

1 x Stroller Frame & Basket

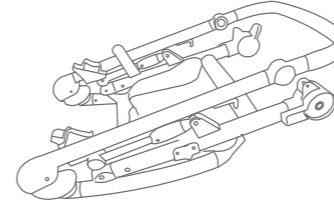

1 x Stroller Seat

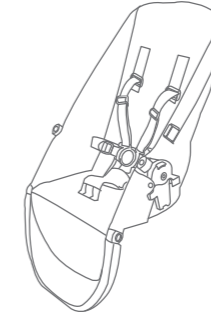

1 x Canopy

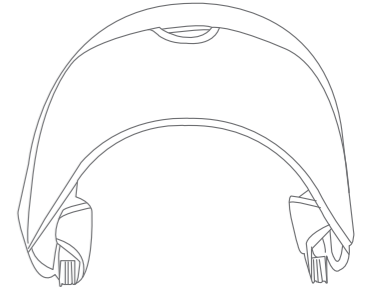

1 x Arm Bar



2 x Front Wheels

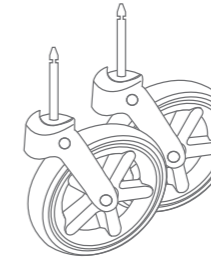

2 x Rear Wheels

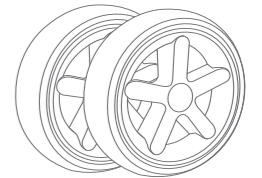

## Included Accessories

1 x Stroller Organiser Bag



1 x Set of Click & Go™ Adaptors

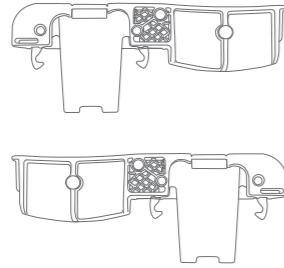

2 x Shoulder Harness Pads



## Optional Accessories

- Steelcraft Click & Go Signature bassinet
- Steelcraft Strider Signature<sup>V5</sup> Second Seat
- Steelcraft Click & Go™ baby capsule adaptors for Strider
- Steelcraft Newborn & Toddler Comfort Pack
- Steelcraft Rain Cover
- Steelcraft Shade Cover
- Steelcraft Cup Holder

## Compatible with:

- Click & Go Signature Bassinet
- Strider Signature Second Seat
- Britax and competitor baby capsules

\*For detailed baby capsule compatibility refer to

Australia: [britax.com.au](http://britax.com.au)



New Zealand: [britax.co.nz](http://britax.co.nz)



## Stroller Features

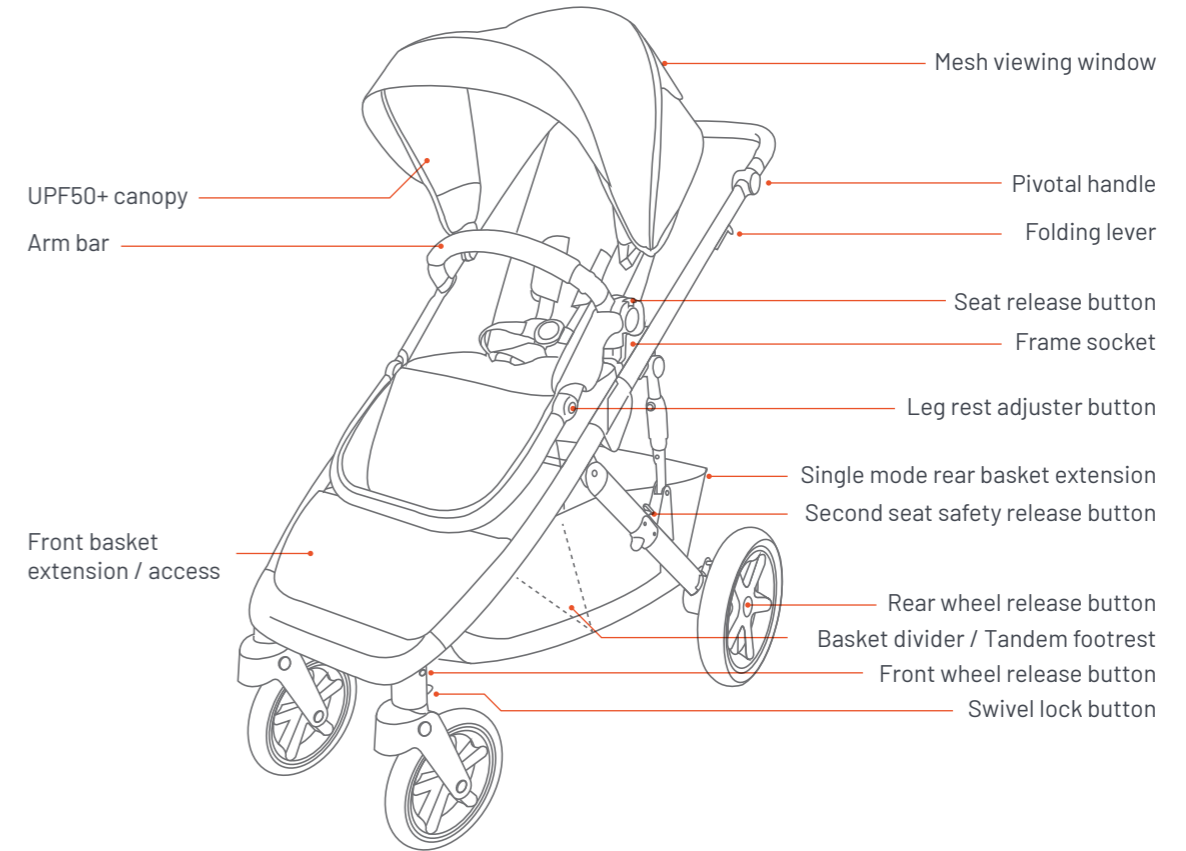

## Stroller Features

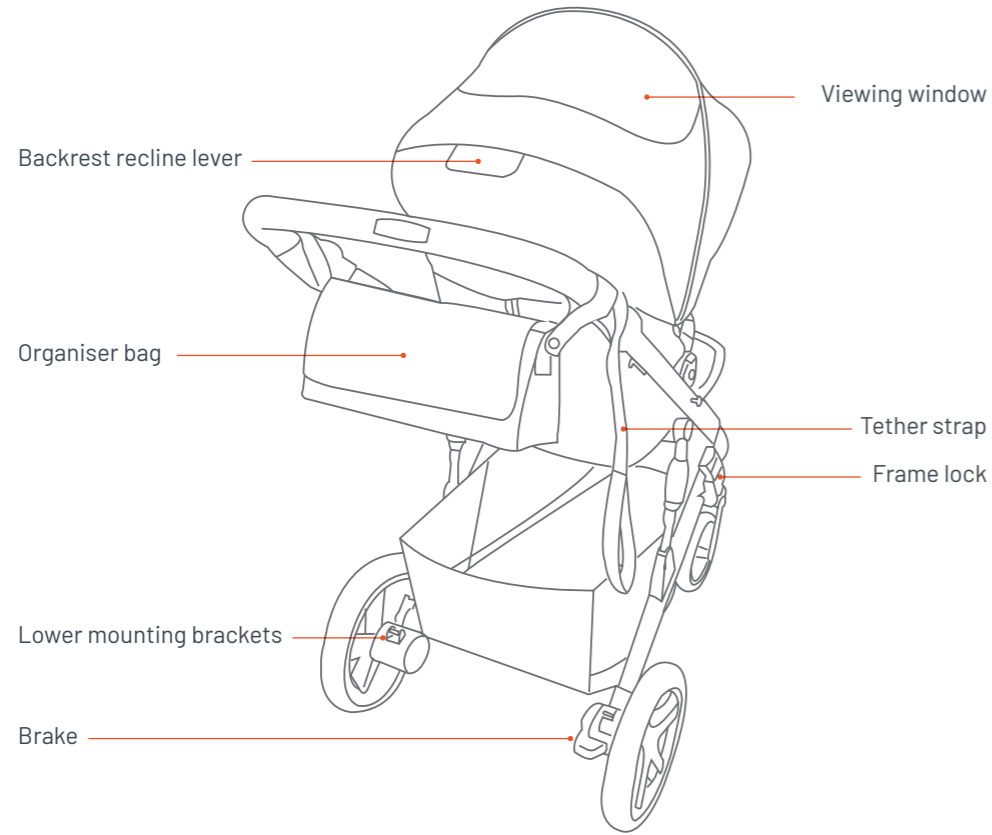

## Stroller Configurations

**PLEASE NOTE:** These configurations are reference only. Refer to our website ([britax.com.au](http://britax.com.au)) for most up to date compatibility. Shown with optional accessories (*sold separately*).

**DO NOT** exceed maximum weight limits defined in the **Baby Capsules** or **Accessory instruction manuals**.

### Single

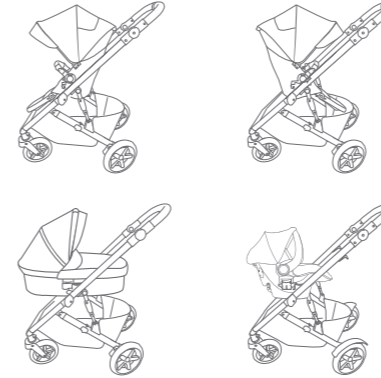

### Double



It is recommended to use the extension adaptors (**supplied with the Second Seat**). There are various positions available for double mode, please adjust seat positions and do not use the positions if there is not enough space for the lower child.

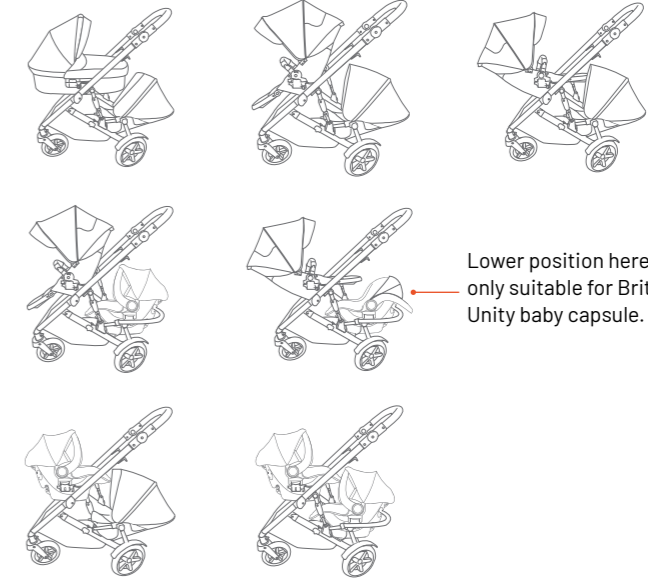

Lower position here is only suitable for Britax Unity baby capsule.

## Stroller Assembly

### IMPORTANT NOTES:

PLEASE REFER TO PAGE 6 FOR SMART LIFTING TECHNIQUES.

- Release the storage latch with due care and open the frame.
- When opening the stroller, be aware of the danger of being injured by moving parts and locking devices during the process. Keep all hands and limbs clear of these parts.
- There is potential for fingers or parts of the body to be injured when the stroller is being unfolded, due care should be exercised.
- Keep children clear of the stroller when unfolding the stroller.
- Open the stroller slowly and be careful where you place your hands. Keeping your hands on the handle is the best way to unfold the stroller.

### Opening the Stroller Frame

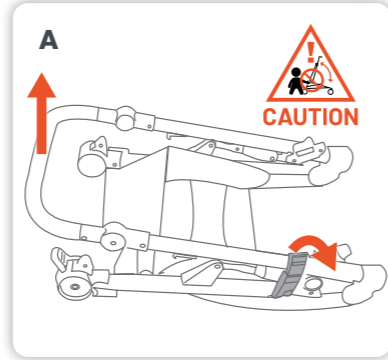

**A** Push the release on the frame lock and open the frame.

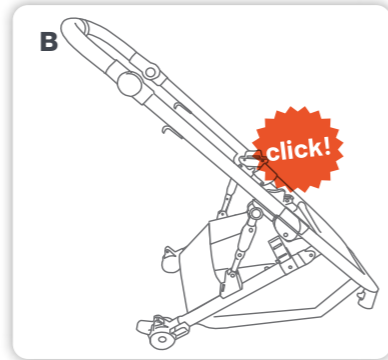

**B** Lift handle until frame locks into upright position.

## Stroller Assembly

### Attaching or Removing the Rear Wheels

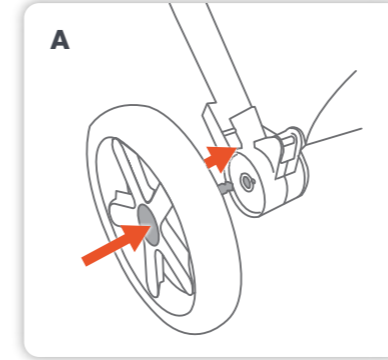

**A** Hold in the rear wheel release button in the centre of the wheel and slide the mounting pin into the housing on the rear axle. Please ensure it is locked.

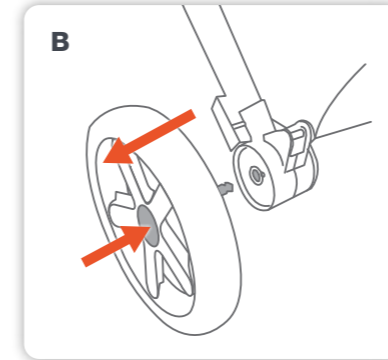

**B** To remove the rear wheels, press and hold the release button in the centre of the wheel and pull away from the wheel housing.

### Attaching or Removing the Front Wheels

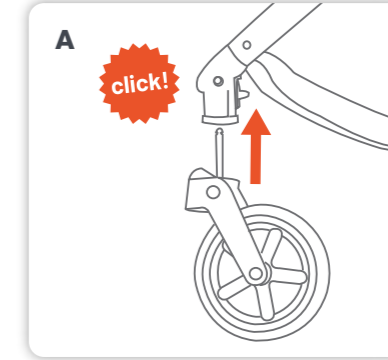

**A** Slide the front wheel mounting pins into the housing on the frame until they lock into place. Please ensure it is locked.

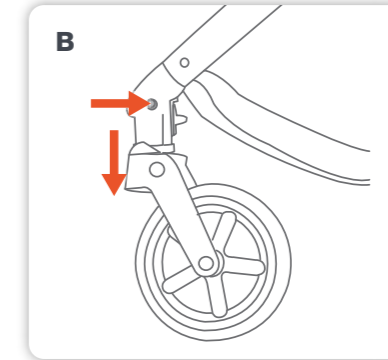

**B** To remove the front wheels, push front wheel release button and pull the wheel out of the housing.

## Stroller Assembly

### Attaching the Stroller Seat

#### IMPORTANT NOTE:

Always remove your child from the stroller seat before installing, removing or changing the seat direction.

✔ **TIP:** The seat is reversible so it can be attached to the frame in the forward-facing position or the rearward-facing position.

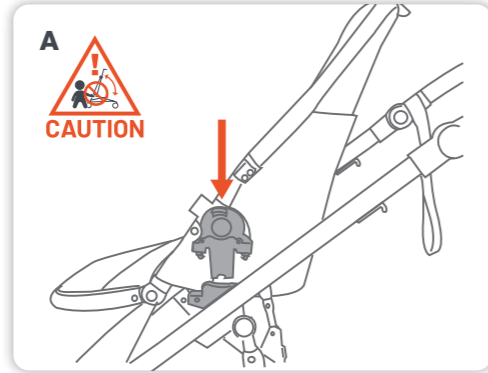

**A** Hold the stroller seat over the frame and align the seat connectors with frame sockets.

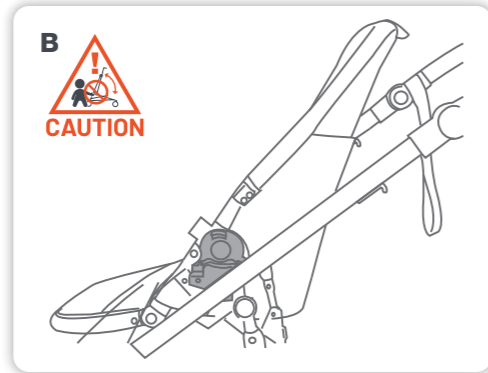

**B** Push down the seat until both stroller seat connectors have locked into the frame sockets. Please ensure the seat is locked.

## Stroller Assembly

### Attaching the Canopy

**IMPORTANT NOTE:** The sun is very strong. **DO NOT LEAVE YOUR CHILD EXPOSED TO THE SUN.** The canopy or hood on this product will not give your child total protection from the harmful rays of the sun.

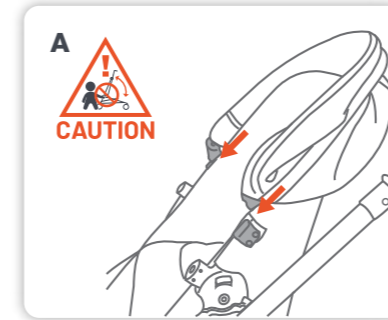

**A** Fit the canopy over the back of seat and slide the canopy mouldings onto the canopy frame mouldings until they interlock together.

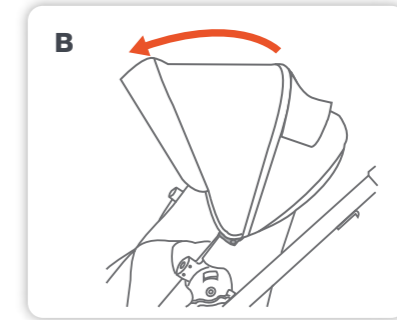

**B** To adjust the canopy, open by pulling forward, or close by pushing the canopy backward.

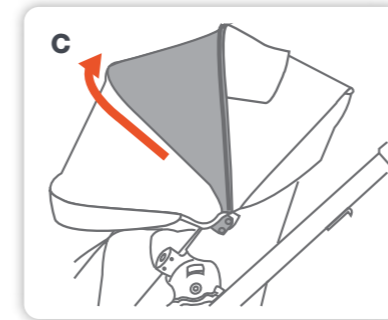

**C** To expand the canopy unzip the centre section of the canopy.

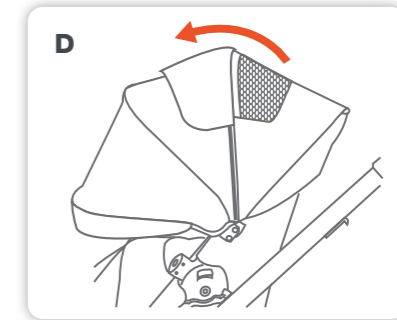

**D** There is a viewing window for ventilation and observation.



## Stroller Assembly

### Attaching the Arm Bar

WHEN A CHILD IS IN THE STROLLER, KEEP THE ARM BAR ATTACHED AT ALL TIMES.



**A** Align the pins on each side of the arm bar with the arm bar sockets on the seat. Press and hold the button underneath the arm bar sockets then slide the arm bar pins into the sockets until it is locked. Please ensure it is locked.

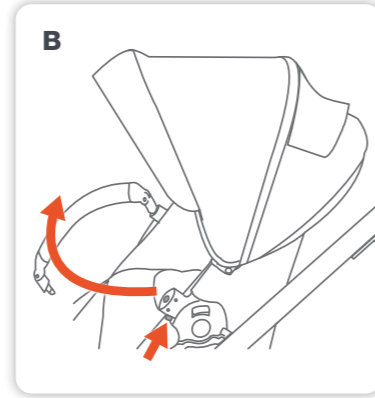

**B** To remove the arm bar, press and hold the button underneath the arm bar and pull the arm bar out. Rotate the arm bar for easy access.

## Stroller Assembly

### Attaching the Organiser Bag

#### IMPORTANT NOTE:

Do not place more than 1.5 kg in the organiser bag. Disconnect the shoulder strap when using on the stroller.

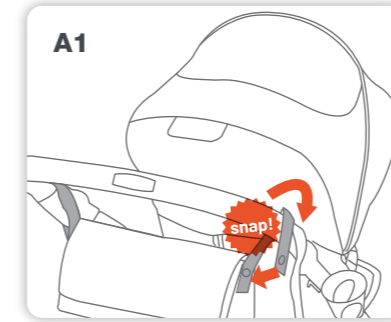

**A1 + A2** Position your organiser bag loop just above the height adjuster and snap the press stud on both sides.

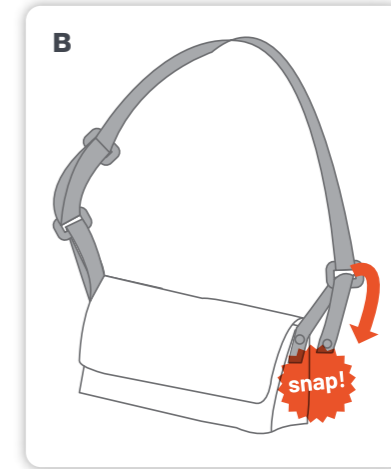
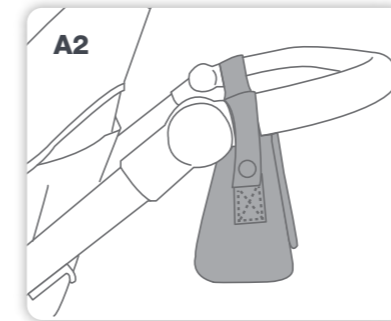

**B** Thread the hanging strap on both sides through the D ring on the end of the shoulder strap. Store the shoulder strap when not in use.

## Stroller Assembly

### Installing the Newborn Comfort Insert

Sold Separately

#### IMPORTANT NOTES:

- The newborn back support wedge has been designed to help improve and provide a more supportive seating position for newborn or lower birth weight babies.
- The stroller seat should be used in the fully reclined position with the newborn back support wedge.
- The newborn back support wedge should be removed as your baby grows.
- While using this product regularly check to ensure that the harness straps remain tight.
- Ensure that the shoulder straps are fitted through the appropriate harness slots to suit your child's seated shoulder height.

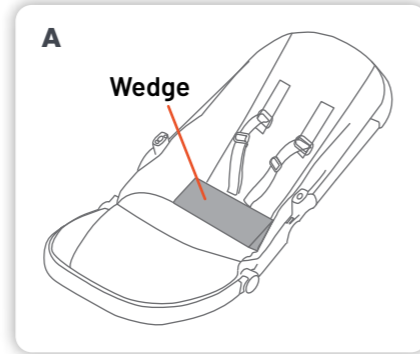

**A** To use the newborn back support wedge, place the newborn back support wedge firmly in the seat.

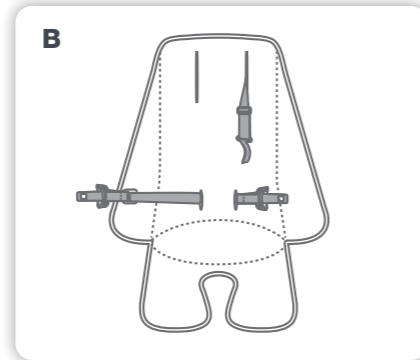

**B** Place the insert on the stroller seat and thread the waist and shoulder harness straps through the buttonholes in the back of the seat insert.

## Stroller Assembly

### Installing the Newborn Comfort Insert

Sold Separately

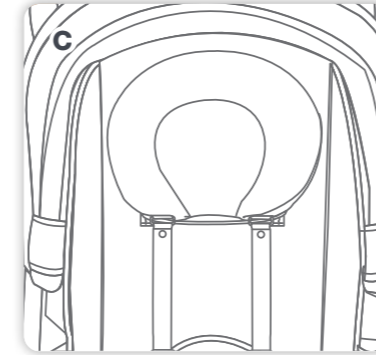

**C** To use the head pillow, place the head pillow elastic behind the shoulder harness strap.

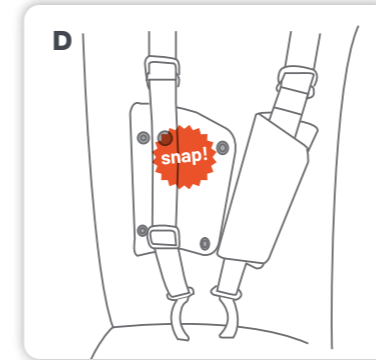

**D** Slide the shoulder pads through the shoulder harness and close the stud on the shoulder harness with one in the shoulder pads to keep the shoulder pads in place.

## Stroller Operation

### Attaching the Cup / Bottle Holder

Sold Separately

#### IMPORTANT NOTES:

- Do not place over 1 kg in the cup / bottle holder.
- Do not place hot drinks in the cup / bottle holder.
- Remove contents from the cup / bottle holder before folding the stroller.



**A** The cup / bottle holder can only fit on the right-hand side of the frame. Push the cup / bottle holder attachment to the connector on the frame.

## Stroller Assembly

### Installing the Shade Cover

Sold Separately

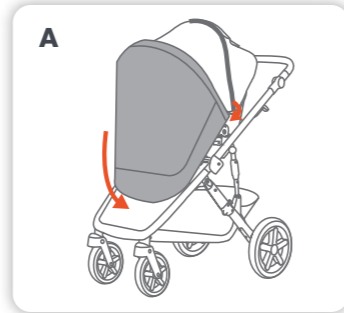

**A** Fit the sun shade over the canopy front and secure the toggle and elastic loop around the canopy frame then pull to the front and secure with the elasticised end.

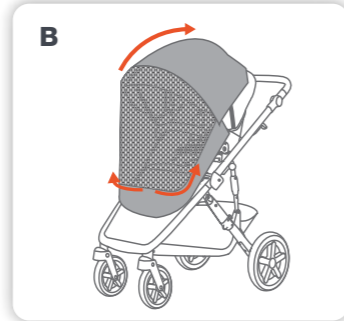

**B** Lift the sun shade cover flap to use mesh panel for ventilation and open zipper to access the baby.

## Stroller Assembly

### Installing the Rain Cover

Sold Separately

#### IMPORTANT NOTES:

- Ensure rain cover is kept away from the child's face.
  - Refit rain cover if required to ensure child is safe.
- ✔ **TIP:** The rain cover can be used in both single and tandem modes. An extension panel is also provided which is easily secured to the single mode rain cover with a zip.



**A** Pull the front elastic section of rain cover over the leg rest. Ensure the rain cover fits snugly over the canopy and is securely fitted to stroller seat.

### Using the Tandem Extension:

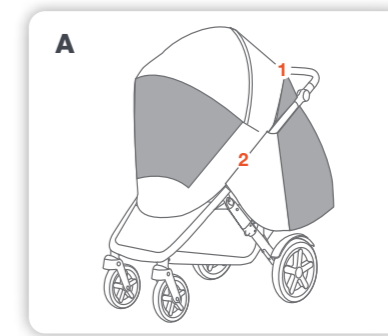

**A** Attach the rain cover extension as required and secure to the rain cover with the zipper (1) and hook & loop (2) attachments.

### Accessing your child:

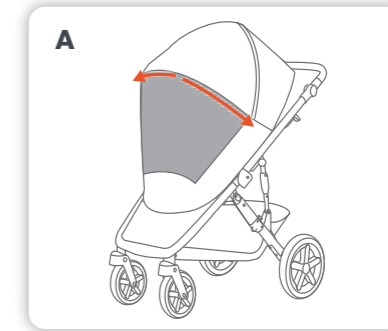

**A** Open zipper (dashed orange line) to access the baby.

## Stroller Operation

### Using the Brakes

**⚠️ WARNINGS:** ALWAYS APPLY THE BRAKES WHEN THE STROLLER IS STATIONARY.



**A** To engage the brake, step on the red brake pedal until you hear a 'click'. The indicator window will change to red.

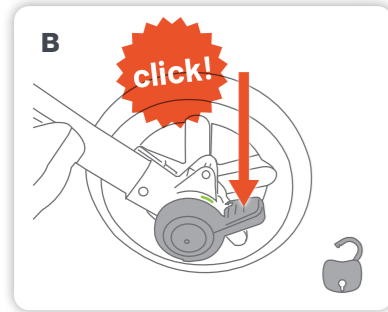

**B** To disengage the brake, step on the red brake pedal until you hear a 'click'. The indicator window will change to green.

### Using the Front Wheel Swivel Lock

**PLEASE NOTE:** Always lock the swivel wheels when using the stroller on rough surfaces as this will minimise wheel wobble. The swivel wheels should only be locked when the wheels are in the trailing position (wheels under frame).

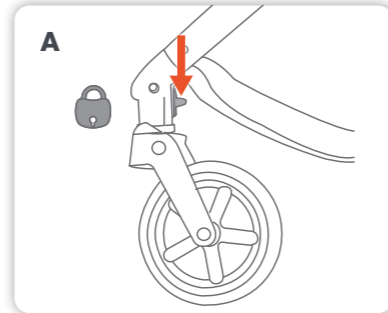

**A** To lock the front wheels into the fixed position, press the grey swivel lock down on both wheels until they lock into position.

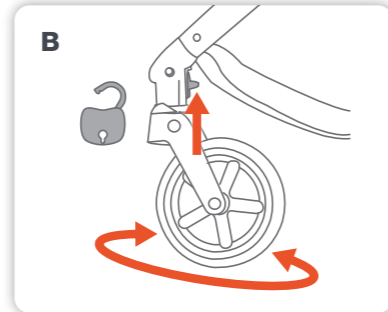

**B** To allow the wheels to swivel, push the grey swivel wheel lock up on both wheels until they lock into position.

## Stroller Operation

### Adjusting the Backrest

**⚠️ WARNINGS:**

- THE UPRIGHT POSITIONS ARE NOT SUITABLE FOR USE WITH CHILDREN LESS THAN 6 MONTHS OLD.
- THE LOWEST RECLINE POSITION SHOULD BE USED TO TRANSPORT BABIES. THE BACKREST CAN BE ADJUSTED TO A MORE UPRIGHT POSITION AS THE CHILD GROWS OLDER AND IS ABLE TO SUPPORT ITS HEAD WITHOUT ASSISTANCE.

**✔️ TIP:** If the child is sitting in the seat, support the backrest as it reclines. If you have difficulty adjusting the backrest you may need to remove the child from the seat to allow you to raise or lower the backrest with ease.

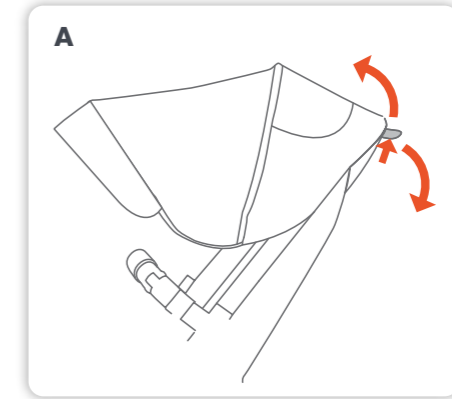

**A** Lift the recline lever on the back of the seat and hold while raising or lowering the backrest to the desired position.  
**✔️ TIP:** There are **four** backrest positions.

## Stroller Operation

### Adjusting the Leg Rest

#### IMPORTANT NOTES:

- The leg rest feature is provided for your child's comfort.
- The leg rest is not designed to support extra weight.
- Do not allow children to stand or sit on the leg rest, it will disengage if extra weight is applied.
- If leg rest disengages simply lift up again to reset leg rest mode.

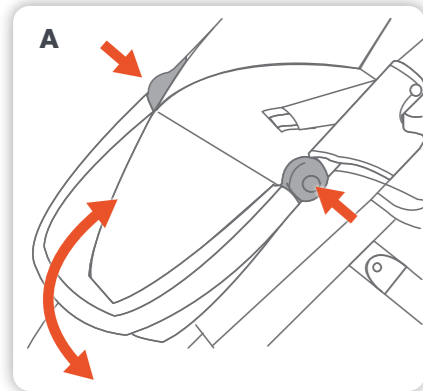

**A** Press the two release buttons on both sides of the leg rest hinge and hold while raising or lowering the leg rest to the desired position.

### Adjusting the Pivoting Handle

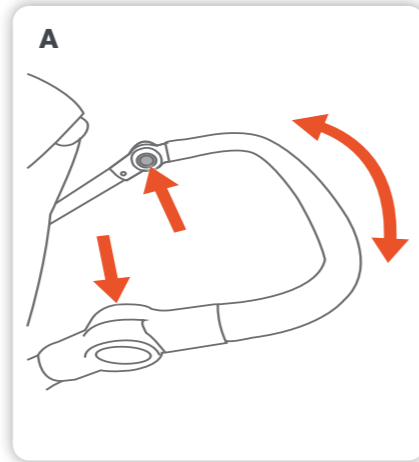

**A** Press the two release buttons on the inside of the handle and hold while raising or lowering the handle to the desired position. When the desired height has been achieved let go of both release buttons.

**TIP:** The pivotal handle has five positions.

## Stroller Operation

### Securing the Child Harness

#### ! WARNINGS:

- **USE THE HARNESS AT ALL TIMES.**
- **ENSURE YOUR CHILD IS SECURED WITH A CORRECTLY ADJUSTED HARNESS.**
- **THE ADJUSTED HARNESS SHOULD CLOSELY FIT THE CHILD.**
- **NEVER LEAVE THE HARNESS BUCKLED WHEN NOT FITTED TO A CHILD IN THE STROLLER, BECAUSE THE HARNESS CAN FORM LOOPS WHICH MAY POSE A STRANGULATION HAZARD.**
- **WHEN HARNESS IS NOT IN USE, DISCONNECT SHOULDER STRAPS FROM THE WAIST STRAPS AND BUCKLE TO PREVENT STRANGULATION.**
- A five-point harness is provided to restrain your child.
- Buckle tongues separate for added safety.
- To reconnect buckle tongues and to secure the child in the harness please follow the steps to the right carefully.

**PLEASE NOTE:** Each waist buckle tongue has a raised rib on one side and can only be locked into the buckle assembly with the raised rib facing up. Ensure the harness straps are not twisted as they may become uncomfortable for the child.

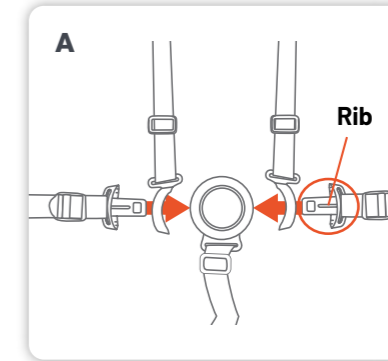

**A** Always apply the brakes before placing child in the stroller seat. Position the shoulder strap near the child's shoulder and position crotch strap between legs. Thread the waist strap buckle tongues through the shoulder straps tongue guides.

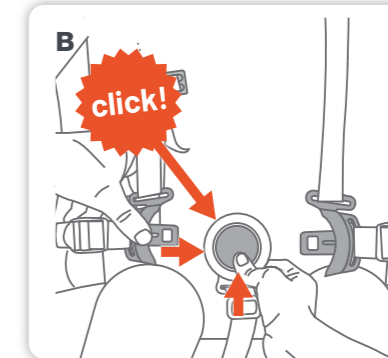

**B** Hold the centre button in on the crotch buckle and insert the waist buckle tongues into the crotch strap buckle until you hear a 'click'. Repeat the procedure on the other side. Please ensure it is locked.

## Stroller Operation

### Adjusting the Harness

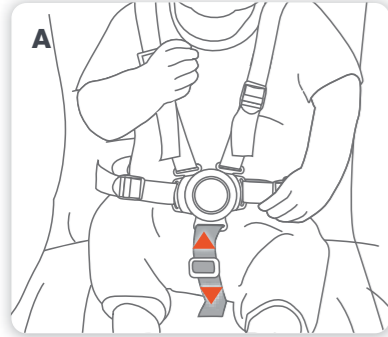

**A** Tighten or loosen the crotch strap by sliding the harness adjuster up or down to the desired fit. Note: The crotch strap should be adjusted to a snug fit.

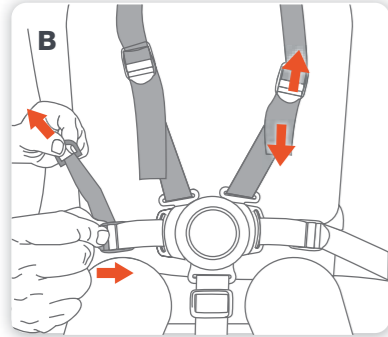

**B** Tighten or loosen the waist and shoulder straps by sliding the harness adjuster to the desired fit. Note: The straps need to fit firmly around the child.

### Opening the Harness

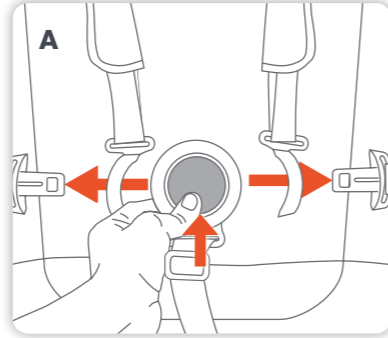

**A** To release the harness, press in the centre of the buckle to release all straps at once.

## Stroller Operation

### Adjusting the Shoulder Harness Height

**IMPORTANT NOTE:** The harness can be adjusted to different heights to accommodate the child. The shoulder straps must be positioned near the child's shoulders.

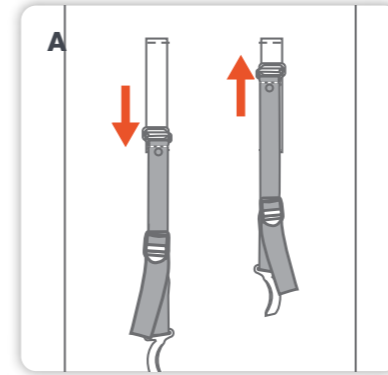

**A** To change the shoulder harness height, simply held the shoulder harness and slide up and down to desired position.

### Using the Storage Basket

**IMPORTANT NOTE:** Do not place more than 12kg in the basket at single mode or 4kg at tandem mode.

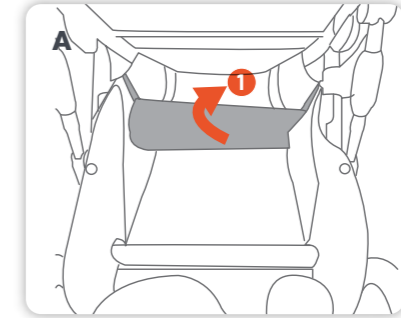

**A** There is basket divider in the base of the basket, lift the basket divider up and press the snaps on the side to create the division in the basket.

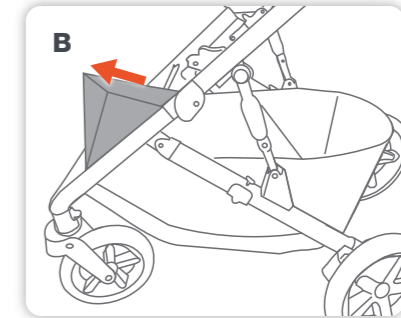

**B** The front of the basket can be extended by pulling out to allow for additional storage and easy access to the basket.

## Stroller Operation

### Using the Tether Strap

**⚠ WARNINGS:** USE THE TETHER STRAP TO STOP THE STROLLER ROLLING AWAY.

- THE STROLLER IS DESIGNED FOR USE ON FLAT OR GENTLY SLOPING SURFACES, AND MAY BE UNSTABLE ON HIGHER SLOPING AND UNEVEN SURFACES AND USERS SHOULD BE AWARE OF THE POSSIBILITY OF THE STROLLER ROLLING AWAY OR TIPPING OVER.
- NEVER LET GO OF THE STROLLER WHEN PARKED ON AN INCLINE OR SLOPING SURFACE BECAUSE IT MAY SLIDE OR TIP OVER. ALWAYS PARK ON A FLAT SURFACE AND APPLY THE BRAKES.
- ALWAYS APPLY THE BRAKES WHENEVER THE STROLLER IS STATIONARY.

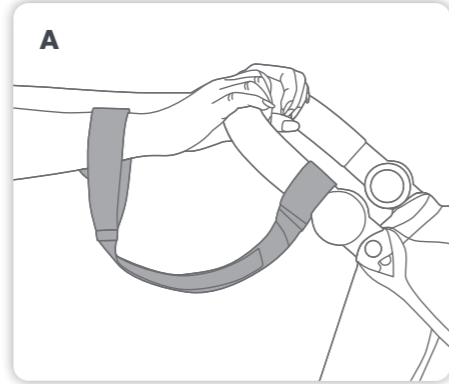

**A** A wrist tether strap is provided on the handle grip. Slide your hand through the tether strap loop whenever you use the stroller. Only remove your hand from the tether strap loop when the brakes have been applied to the stroller wheels.

## Stroller Operation

### Removing & Reversing the Stroller Seat

#### IMPORTANT NOTE:

Always remove your child from the stroller seat before installing, removing or changing the seat direction.

✔ **TIP:** The seat is reversible so it can be attached to the frame in the forward facing position or the rearward facing position.

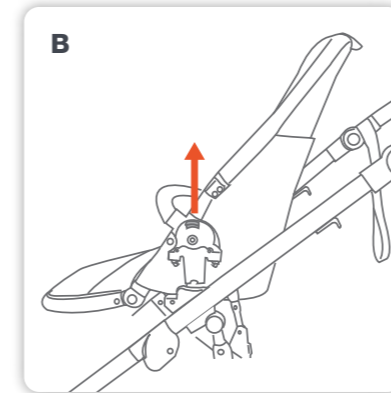

**B** Continue to press in and hold the grey stroller seat release button and lift the stroller seat up and away from the stroller frame.

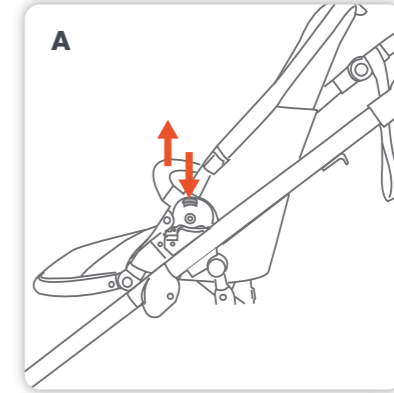

**A** Hold the stroller seat or arm bar on both sides with your hands. Then with your finger or thumbs, press in and hold the grey stroller seat release buttons.

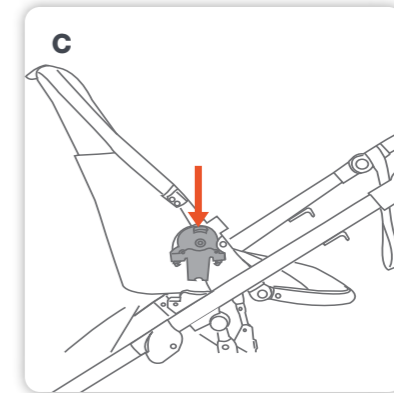

**C** Turn the seat facing opposite direction and then attach the stroller seat to the frame in the rearward facing position.

## Stroller Operation

### Using the Stroller

PLEASE REFER TO PAGE 6 FOR SMART LIFTING TECHNIQUES.

- Always ensure you bend your knees where appropriate and take due care when lifting the frame.
- With your hand through the wrist tether strap loop, push the stroller holding the handle.
- The stroller can be steered in the desired direction – allowing the front wheels to swivel will make this easier.
- The front wheels may wobble or oscillate when walking fast, locking the front swivel wheels will stop this.
- The stroller can be taken up kerbs by either pressing down on the handles and raising the front wheels or turning the stroller around and pulling the stroller up the kerb.
- Caution is required when pushing the stroller on a steep slope as the stroller may become unstable. Always hold the handle firmly.
- Do not run with the stroller.
- Whenever you stop, always apply the brakes before you leave the stroller.
- To ensure the safety of your child only hang the supplied bag from the handle bar and use the basket to store all other bags or goods.

## Stroller Operation

### Folding the Stroller

PLEASE REFER TO PAGE 6 FOR SMART LIFTING TECHNIQUES.

#### IMPORTANT NOTES:

- Remove the child from the stroller before commencing any folding operation.
- Fold the stroller slowly and be careful where you place your hands.
- When folding the stroller, be aware of the danger of being injured by moving parts and locking devices during the process. Keep all hands and limbs clear of these parts.
- There is potential for fingers or parts of the body to be injured when the stroller is being folded, due care should be exercised.
- Keep children clear of the stroller during folding the stroller.

**PLEASE NOTE:** The stroller seat and wheels can be removed to reduce the total folded size.

With the stroller seat attached, folding the leg support will also help to reduce the folded size.

#### FOLDING TIPS:

- 01.** For easier handling. It is recommended to remove the stroller seat from the frame (Refer to Page 29) before folding. Then fold the frame and put both the seat and frame in the car.
- 02.** For smaller cars, it may be convenient to simply remove the rear wheels.

#### IMPORTANT NOTES:

- Remove the **Bassinet** or **Baby Capsule** if connected to the frame prior to folding.
- The **Second Seat** can either be removed or folded up prior to folding.
- The rain cover must also be removed if fitted.



## Stroller Operation

### Folding the Stroller

PLEASE REFER TO PAGE 6 FOR SMART LIFTING TECHNIQUES.

- Remove the child from the stroller.
- Engage the brakes. (Refer to Page 22)
- Ensure the front wheels are in swivel mode so the front wheels will automatically position under the stroller during folding. (Refer to Page 22)
- Close the canopy. (Refer to Page 15)
- Adjust the leg rest to the lowest position. (Refer to Page 24)
- Make sure the handle height is set to the highest position aligned with the frame to prevent the handle coming in contact with the wheels when folded.

✔ **TIP:** It is recommended to remove the stroller seat from the frame (Refer to Page 29) before folding. Then fold the frame and put both the seat and frame in the car.

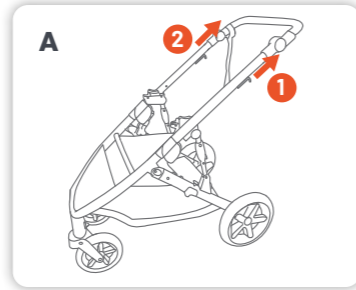

**A** Ensure to always engage the brake. Slide the folding levers **1 & 2** towards you and begin to push the handle down towards the ground to fold.

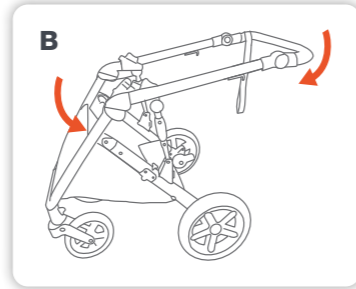

**B** Continue folding all the way down until frame is fully folded and frame lock is engaged.

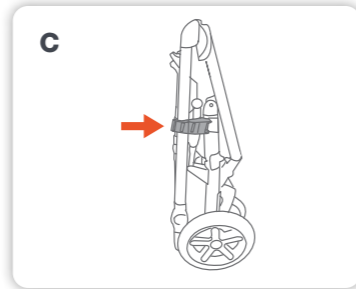

**C** Ensure the frame is securely locked.

## Stroller Operation

### Folding the Stroller

## CAUTION:

**IF YOU HAVE CHOSEN NOT TO REMOVE THE STROLLER SEAT FROM THE FRAME THE STROLLER CAN BE FOLDED WITH THE TOP SEAT AND SECOND SEAT ATTACHED TO THE STROLLER FRAME, HOWEVER, CAUTION MUST BE TAKEN WHEN LIFTING THE STROLLER BECAUSE OF THE OVERALL WEIGHT.**

✔ **TIP:** The stroller can fold with seat in any position however stroller seat in the forward facing position will achieve a more compact fold.

Adjust the pivotal handle to the highest position (Refer to Page 24), this will prevent the handle coming into contact with the second seat and causing damage to the stroller when folded.

### Lifting & Carrying the Stroller

PLEASE REFER TO PAGE 6 FOR SMART LIFTING TECHNIQUES.

## IMPORTANT NOTE:

**TO AVOID INJURY:** Bend your knees when opening, lifting, carrying, folding, unfolding or adjusting the stroller or any accessories.

## Stroller Operation

Included with stroller

### Installing the Click & Go™ Adaptors

#### **WARNINGS:**

**THE STRIDER CLICK & GO™ ADAPTORS MUST BE ATTACHED TO THE STROLLER FRAME BEFORE ATTEMPTING TO INSTALL THE STEELCRAFT CLICK & GO™ BASSINET OR BRITAX BABY CAPSULE.**

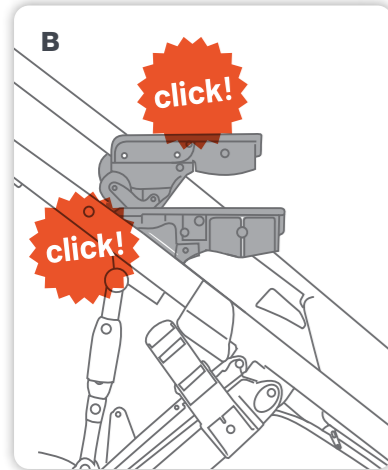

**B** Press firmly down on the Click & Go™ adaptors until you hear a 'click' which indicates the adaptors have locked into the stroller frame sockets.

Pull up on the Click & Go™ adaptors to ensure they are locked into the frame sockets.

The adaptors are marked with right (R) and left (L) inside and it will fit one orientation only.

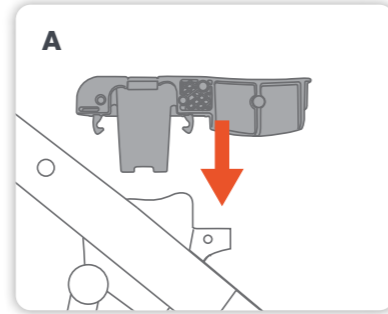

**A** Align the Click & Go™ adaptors into the stroller frame sockets.

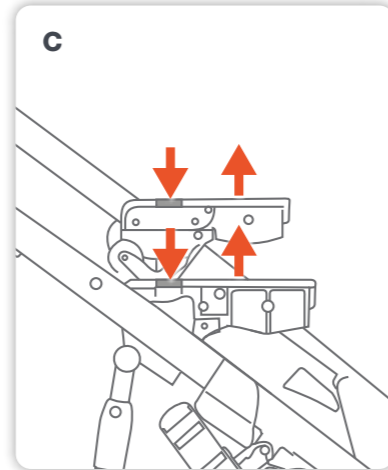

**C** To remove the Click & Go™ adaptors, press in and hold the button on the top of the adaptor and pull up the adaptors out of the frame sockets.

## Bassinet

Sold Separately

### Attaching and Removing the Bassinet

#### **WARNINGS:**

- DO NOT USE THE BASSINET ONCE THE CHILD CAN SIT UP.
- IT IS UNSAFE TO USE ACCESSORIES NOT APPROVED FOR USE WITH THIS STROLLER.
- DO NOT USE ANY ACCESSORIES OTHER THAN THOSE APPROVED FOR USE WITH THIS STROLLER BY BRITAX.
- THE MAXIMUM WEIGHT OF THE CHILD USING THE PRODUCT IS NOT TO EXCEED 9KGS.
- DO NOT USE FOR UNSUPERVISED SLEEPING.

#### **IMPORTANT NOTES:**

- For proper use of the bassinet, please follow the instruction manual provided with the bassinet.
- The Click & Go™ Signature Bassinet and Strider Bassinet are the matching compatible bassinets designed to fit the Strider Signature strollers.
- Remove the stroller seat or baby capsule from the frame before fitting the bassinet.
- Always remove your child from the bassinet before fitting or removing the bassinet from the stroller frame.
- The bassinet must always face towards the handle.
- The bassinet must be removed from the frame before folding.
- Do not lift the stroller by the bassinet.

## Bassinet

Sold Separately

### Attaching & Removing the Click & Go™ Signature Bassinet

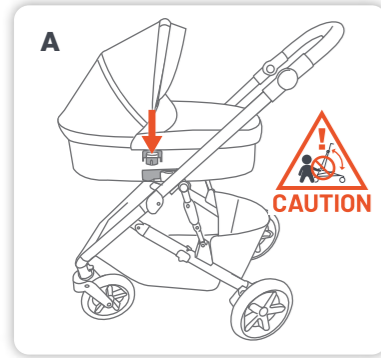

**A** The bassinet must face the stroller handle. Align the bassinet directly over the Click & Go™ adaptors and push down until it locks. Pull up on the bassinet to ensure it is locked.



**B** Hold and lift the bassinet release buttons on both sides then lift the bassinet up and away from the stroller.

## Bassinet

Sold Separately

### Attaching the Strider Bassinet



**A** The bassinet must face the stroller handle. Align the bassinet directly over the frame sockets.



**B** Push the bassinet down until it is locked into the stroller frame sockets. Please ensure it is locked.

### Removing the Strider Bassinet



**A** Firmly lift and hold the bassinet locking lever up to release the bassinet from the stroller frame socket and same time lift the bassinet up with handle.

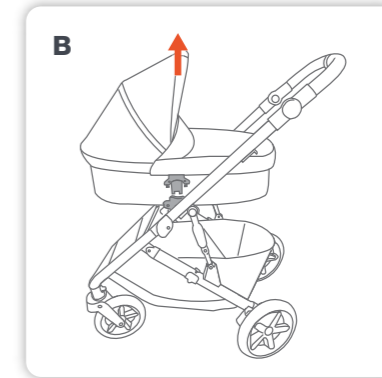

**B** Lift the bassinet completely out of the stroller frame.

## Second Seat

Sold Separately

### Attaching and Removing the Second Seat

#### **WARNINGS:**

- SECURE THE CHILD IN THE HARNESS AT ALL TIMES.
- DO NOT USE ANY ACCESSORIES OTHER THAN THOSE APPROVED FOR USE WITH THIS STROLLER BY BRITAX.
- IT IS UNSAFE TO USE ACCESSORIES NOT APPROVED FOR USE WITH THIS STROLLER.
- THE MAXIMUM WEIGHT OF THE CHILD USING THIS SECOND SEAT IS NOT TO EXCEED 17KG.

#### **IMPORTANT NOTES:**

- For proper use of the second seat, please follow the instructions manual provided with the second seat.
- Do not use this second seat with any other models of stroller.
- The second seat must be correctly fitted and locked onto the stroller frame.
- The second seat can only be used in the forward facing position, connected to the rear of the stroller.
- Do not overload the stroller. Overloading will cause the stroller to tip backwards.
- Remove the back extension of the basket before fitting the second seat.

## Second Seat

Sold Separately

### Removing the Back Extension of the Basket

Note: In order to install the second seat, the basket extension must be removed first. Refer to grey area on image below.

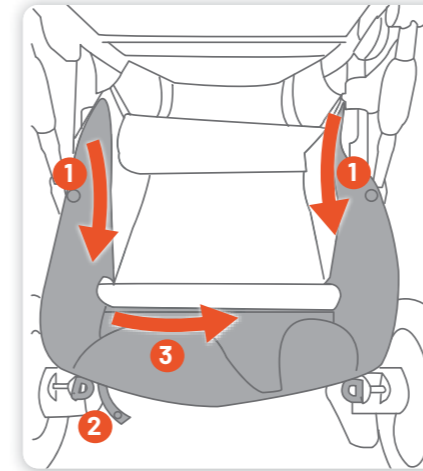

- (1) Remove press studs and velcro on both sides of the frame
- (2) Remove press studs looped around the D-rings near the back wheel housing.
- (3) Unzip the basket extension located under cross bar.

**KEEP THE BASKET EXTENSION IN A SAFE PLACE FOR FUTURE USE.**

## Second Seat

Sold Separately

### Attaching the Second Seat

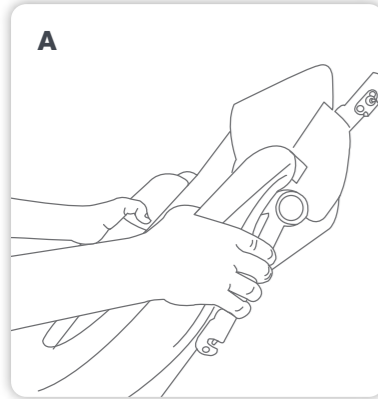

**A** To attach the second seat to the stroller frame fold the support bars on both sides to the back of the seat holding the position.

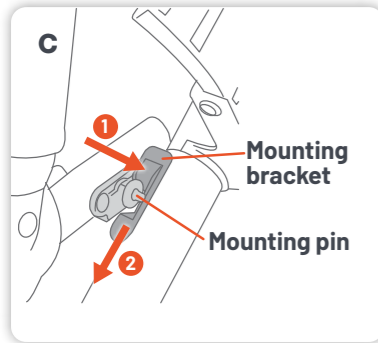

**C** Slide the mounting pins into the mounting brackets (as indicated by arrow 1) on the stroller frame then pull downwards (as indicated by arrow 2).

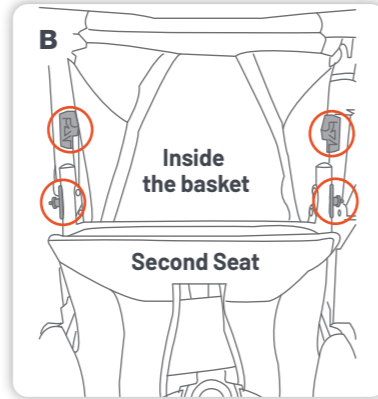

**CAUTION**

**B** Line up the second seat mounting pins with the mounting brackets on the stroller frame. Line up the support bars on the second seat with the lower mounting brackets on the inside of the stroller frame (located on rear wheel housing).

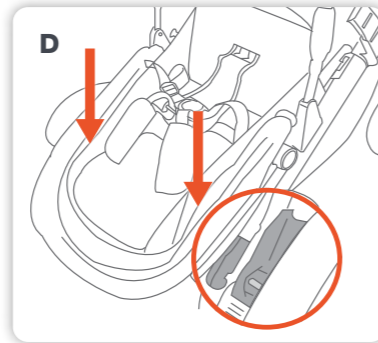

**CAUTION**

**D** Lower the second seat and press down until the support bars are locked into the lower mounting brackets on the inside of the stroller frame (located on rear wheel housing).

## Second Seat

Sold Separately

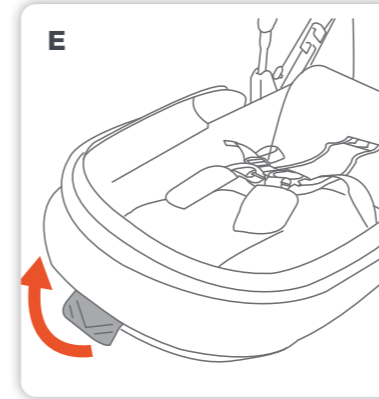

**E** Lift the recline lever of the second seat so the foot end slides completely down and engages into the stroller frame. Pull the second seat upwards to ensure it is locked onto the stroller frame.

### Removing the Second Seat

#### IMPORTANT NOTE:

- Always remove your child from the Second Seat before folding or removing the Second Seat.

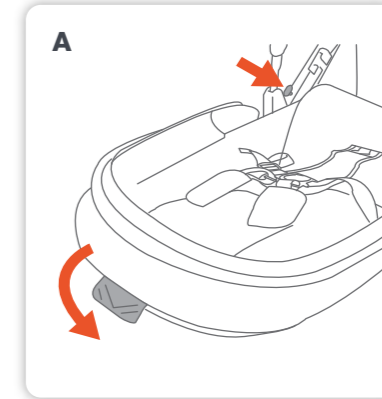

**A** Fold the canopy back, then fully lift the recline lever and lower the second seat to the lowest position.

While still holding the recline lever, press the second seat safety release button and continue to lower the seat...  
(continued next page)

## Second Seat

Sold Separately

### Removing the Second Seat (continued)

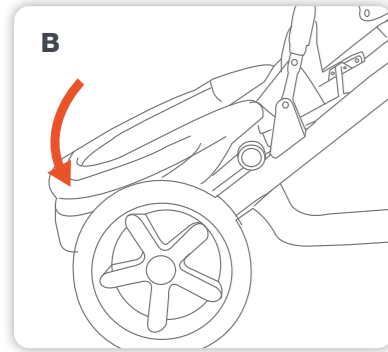

**B** The second seat must be in the fully folded position before removing from the stroller frame.

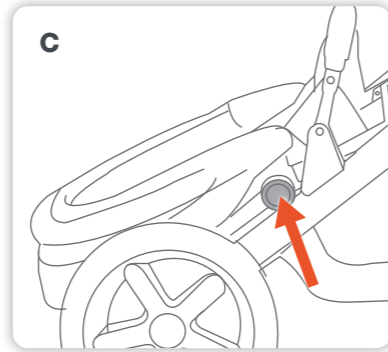

**C** Grasp the sides of the second seat frame and press the second seat release buttons in on both sides of the second seat.

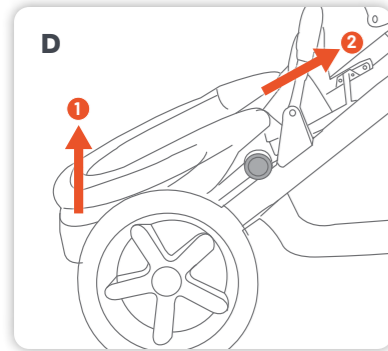

**D** While holding the button, lift the seat up and forward to release the seat.

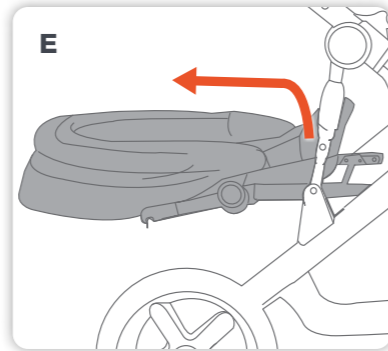

**E** Lift the second seat up and away from the stroller frame.

## Baby Capsule

Sold Separately

### ! WARNINGS:

- IT IS UNSAFE TO USE ACCESSORIES NOT APPROVED FOR USE WITH THIS STROLLER
- DO NOT USE ANY ACCESSORIES OTHER THAN THOSE APPROVED FOR USE WITH THIS STROLLER BY BRITAX.
- DO NOT EXCEED THE MAXIMUM WEIGHT CAPACITY ON THE BABY CAPSULE\*

### IMPORTANT NOTES:

THE STRIDER SIGNATURE V5 STROLLER IS COMPATIBLE WITH THE BRITAX AND COMPETITOR BABY CAPSULES\*. ONLY USE BABY CAPSULES THAT ARE COMPATIBLE TO FIT THIS STROLLER.

\*For detailed baby capsule information on maximum weight capacity and compatibility, refer to:

Australia:  
[britax.com.au](http://britax.com.au)



New Zealand:  
[britax.co.nz](http://britax.co.nz)



- The baby capsule must be correctly fitted and locked onto the Strider Signature stroller frame.

- The baby capsule must only be used on the stroller frame in the rearward facing position (baby facing parent), fitted facing toward the stroller handle in single mode.
- The Baby Capsule must only be used on the second seat frame in the forward facing position, fitted facing toward the front of the stroller.
- Secure the child using the baby capsule harness at all times.
- Do not leave the child in the baby capsule for extended periods.
- The baby capsule is designed to provide mobility outside of the car but it should not be used instead of an appropriate cot.
- The baby capsule must be removed from the stroller frame or the second seat frame before folding.
- The sun is very strong. **DO NOT LEAVE YOUR CHILD EXPOSED TO THE SUN.** The canopy or hood on this product will not give your child total protection from the harmful rays of the sun.

## Baby Capsule

Sold Separately

### Attaching & Removing the Britax Unity Baby Capsule

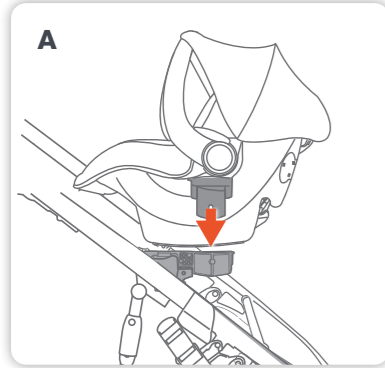

**A** Align the Unity Baby Capsule with the Click & Go™ adaptors. The baby capsule must be facing the handle in both single and tandem modes.

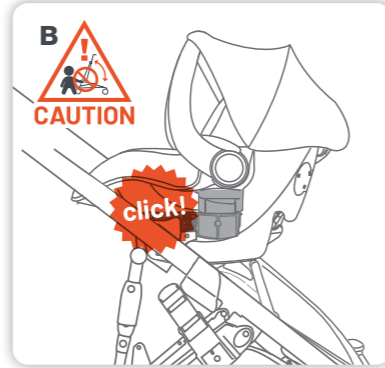

**B** Press firmly down on the Click & Go™ adaptors until you hear a 'click' which indicates the baby capsule has locked into position. Pull up the baby capsule to ensure they are locked into the stroller frame.

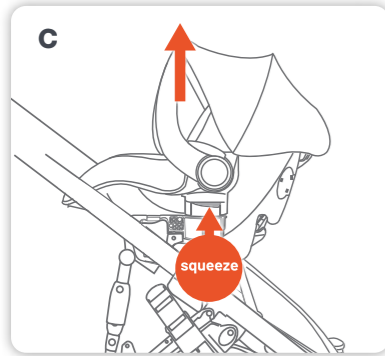

**C** Before removing the baby capsule, lock the stroller brake first. Squeeze both release levers on the Click & Go™ adaptors at the same time and support the weight of the baby capsule. Lift and remove the baby capsule from the stroller frame.

**PLEASE NOTE:** These instructions are for installing and removing the baby capsule on the stroller only.

- For installing and proper use of the baby capsule in the car, please follow the instructions manual provided with the baby capsule.
- Ensure the baby is secured in the baby capsule with the harness at all times. Refer to the baby capsule instruction manual regarding placing and securing your baby in the baby capsule.
- For attaching or removing competitor baby capsules refer to instruction manual provided with the baby capsule.

## Care & Maintenance

### General Maintenance & Repair

- To maintain the safety and longevity of the stroller, seek prompt repairs or replacement for bent, torn, worn, or broken parts. Do not continue to use the stroller if unsafe.
- All repairs should only be carried out by an authorised Britax/Steelcraft repairer. Only Britax/Steelcraft replacement parts should be used with the stroller. It may be unsafe to use parts supplied from another manufacturer.

**Do not fold or store the stroller if damp or wet**, as fabric may develop mould or mildew. Always store the stroller inside in a dry, well-ventilated area.

**Do not place heavy objects on top of the stroller** as it may alter the shape.

**If there are compression marks on the tyres**, use a domestic hair dryer to gently warm (DO NOT OVERHEAT) the tyre and the compression marks should slowly disappear.

#### General Tips

**Do not store the stroller in your car** for prolonged periods of time during summer as it may lead to damage to some of the plastics components.

**Do not leave the stroller in direct sunlight** for extended periods of time, as colours of some fabrics may fade, and tyres may deteriorate.

Should you have any further questions on care & maintenance of the stroller, please contact our Consumer Service Team at:  
[aunz-support@britax.com](mailto:aunz-support@britax.com)

## Care & Maintenance

### Cleaning

#### Fabrics

- Removable fabrics may be cleaned using lukewarm water and soap or mild detergent. Rinse thoroughly and allow to dry away from direct sunlight.
- Non-removable fabrics can be spot cleaned using a damp sponge and soap or mild detergent. Allow to dry completely before re-use or storage.
- Never use bleach, or abrasive cleaning products.
- **DO NOT** iron or dry clean.

**NOTE:** **DO NOT** place any of the stroller fabrics in the dryer. Allow to dry naturally, away from direct sunlight.

#### Frame

- Remove dirt and dust away from any moving mechanism.
- Clean frame with a soft damp cloth and soap or mild detergent and allow to dry thoroughly.
- **DO NOT** use abrasive cleaning products as it may cause stains, discolouration or scratches to the frame.
- **DO NOT** soak or submerge frame in water.
- **DO NOT** remove, dismantle or alter any part of the stroller mechanism or brakes.

#### Leatherette

- Spot clean with a damp soft cloth.
- **DO NOT** use a dripping wet cloth or wet the leatherette excessively.

#### Wheels

- Remove wheels from stroller.
- Clean with damp cloth and soap or mild detergent. Use brush to remove dirt and mud build up around the tyre. Allow to dry thoroughly before placing wheels back on the frame.
- If necessary lubricate wheel shaft with a small amount of lubricant before placing into the stroller.
- Ensure the stroller is cleaned thoroughly after using it on the beach as sand and salt can damage stroller mechanism, wheel assembly, causing premature wear and corrosion.

#### PLEASE NOTE:

Our product warranty does not cover any rust to the rivets or screws, if you are caught in the rain or at the beach always thoroughly dry the frame to avoid any rust damage.

## Care & Maintenance

Just like servicing your car or bicycle, prams and strollers also need **regular maintenance checks**. These checks can improve product performance, extend the life of your stroller and help to provide you and your children a safe and smooth journey.



We recommend servicing your stroller every 6 months and completing an inspection once a month. To prolong the life of your stroller, a regular maintenance should be performed.

### 5 STEP CHECK LIST

- 01 INSPECT SAFETY DEVICES** tether strap, frame lock, harness, buckle and brakes, and ensure all are in working order and free from dirt, sand, and debris.
- 02 INSPECT** all connecting rivets and screws are secure.
- 03 MAKE SURE FOLDING JOINTS** are free of dirt, dust, and debris by cleaning with a damp cloth, allow to dry and lightly spray with a dry silicon lubricant. Please carefully read the lubricant instructions prior to use.
- 04 REMOVE WHEELS** and wipe clean with a damp cloth to remove any dirt, sand or debris. Allow to dry and lightly spray the wheel pivot pin with a dry silicon lubricant to keep the wheels moving smoothly. Please carefully read the lubricant instructions prior to use.
- 05 ENSURE WHEN FOLDING AND STORING** to wipe down your stroller frame and allow to dry before storing in a dry place without direct sunlight.



## Warranty

### Did you know?

Registering your product online simplifies proof of purchase in the event of a warranty claim.

Head to our website to fill out the product registration form: [britax.com.au](http://britax.com.au)  
[britax.co.nz](http://britax.co.nz)



### Making A Warranty Claim

Your rights under a **Britax** company warranty are separate from and independent of your rights under the statutory consumer guarantees. What you need to do to enforce your rights under a statutory consumer guarantee is set out in the **Australian Competition and Consumer Commission's Consumer Guarantees - A Guide for Consumers**.

To make a claim under a **Britax** company warranty, please contact our customer service team on:

**Australia:** 1300 303 330 / **New Zealand:** 0508 688 822 or alternatively by email at [aunz-support@britax.com](mailto:aunz-support@britax.com)

#### You will be required to :

- Return the product to the place of purchase or to a designated repair agent;
- Present your receipt as proof of purchase;
- Identify the defect in the product; and
- Present the product to **Britax** for inspection on request.

**Britax** will advise you whether the product is covered by the **Britax** company warranty. **Britax's** decision of whether a product is covered by a **Britax** company warranty is final. **Britax** will act reasonably when determining whether a product is covered by a company warranty.

## Warranty

### Australian Consumer Law

On all of our goods, you have the benefit of a statutory consumer guarantee. In summary, goods are guaranteed to be of "acceptable quality" (fit for purpose), goods are guaranteed to match any sample against which they are sold. These consumer guarantees are provided for by the Australian Consumer Law and, if you believe any one of these guarantees is not satisfied by a **Britax** product, you have rights under the Australian Consumer law to enforce that guarantee.

Your rights under the statutory consumer guarantees are set out in the **Australian Competition and Consumer Commission's Consumer Guarantees - A Guide for Consumers**.

In addition to the statutory consumer guarantees, **Britax** offers its own company warranty on all of its products. You therefore have the option of seeking redress for defective or faulty product either under the **Britax** company warranty or the statutory guarantees.

After the **Britax** company warranty expires, you still have your rights under the statutory consumer guarantees.

Depending on the product involved, the **Britax** company warranty on the following page applies:

# Warranty

## Steelcraft Strider Signature<sup>V5</sup>



### Lifetime Warranty

This Strider Signature<sup>V5</sup> Lifetime Warranty reflects our confidence in the experience, knowledge and quality of our design, engineering, production and product performance. We test all our products to meet the relevant Australian standards, testing above and beyond these standards to ensure we make conscious choices about how we create our products, taking pride in the fact that we create affordable products to last. We strive to reduce our environmental impact, and add value and confidence for parents wherever we can.

### What is covered by this Strider Signature<sup>V5</sup> Lifetime Warranty?

Britax warrants the Product against defects in materials and workmanship (normal wear and tear excluded) that affect the normal operation of Product. The warranty commences on the date of purchase, in relation to all Products purchased on or after 1 February 2021, and will apply, subject to the exclusions set out below, for the normal lifetime of the Product. The Strider Signature<sup>V5</sup> Lifetime Warranty is limited to the Product only; the warranty does not cover other Britax products or any additional accessories that a consumer may purchase.

### Who is eligible for the Strider Signature<sup>V5</sup> Lifetime Warranty?

This Strider Signature<sup>V5</sup> Lifetime Warranty is limited to consumer-buyers of the Product, purchased from Britax or authorised dealers, for their personal use or personal family or household purposes. Only the original purchaser of the Product is eligible for the Strider Signature<sup>V5</sup> Lifetime Warranty. For the Strider Signature<sup>V5</sup> Lifetime Warranty to apply the original purchaser must have purchased the Product on or after 1 February 2021 and must:

- Register the Product online at <https://www.britax.com.au/service-support/product-registration/> in his or her name; and
- Provide proof of purchase, including the purchase date, within 6 months from the date of purchase of the Product.

### What is not covered by this Strider Signature<sup>V5</sup> Lifetime Warranty?

This Strider Signature<sup>V5</sup> Lifetime Warranty does not apply:

- To Products that are purchased second hand;
- To Products that have been fitted with aftermarket accessories regardless of whether those aftermarket accessories are Britax products or not;
- To Products that are used for rental, hire or other commercial purposes;
- Where the damage or fault is, in whole or part, as a result of incorrect installation, mistreatment, intentional damage;
- In relation to normal wear and tear;
- Where damage is caused by failure to use or maintain the Product other than in normal conditions; or
- Where damage is caused by any use otherwise than in accordance with the instruction manual or service guidelines including instruction videos and any other information supplied by Britax (whether under the Britax name or under another name used by Britax, including Steelcraft) for the Product.

For full Lifetime Warranty terms & conditions please go to:

**Australia:** [britax.com.au](https://www.britax.com.au)

**New Zealand:** [britax.co.nz](https://www.britax.co.nz)



## **Britax Childcare Pty. Ltd.**

A.B.N. 55 006 773 600

Level 4, 650 Lorimer Street, Port Melbourne, Victoria 3207, Australia

**Phone:** (03) 9288 7288 **Fax:** (03) 9311 5798

## **Customer Service**

**Australia:** 1300 303 330 / **New Zealand:** 0508 688 822

Due to our continuing program of development, Britax reserves the right to alter the specifications, color or design without any further notice.

The **Steelcraft** trademark is the property of Britax Childcare Pty.Ltd - Australia.

The **Britax** trademark is the property of Britax Childcare Holdings Limited - UK.

Visit the **Britax** website at: **[britax.com.au](http://britax.com.au)** or **[britax.co.nz](http://britax.co.nz)** or email us at **[aunz-support@britax.com](mailto:aunz-support@britax.com)**

Due to the variations in the style and design of our products the illustrations used in this instruction booklet are generic.

This product is designed to comply with **Australian and New Zealand standard AS/NZS 2088:2013** "Prams and Strollers- Safety Requirements"

Copyright © 2021 Britax Childcare Pty. Ltd. Australia